

**Indian Maritime University**  
**(A Central University, Govt of India)**  
**Supplementary Examinations – March/April 2025**  
**Programme Name: B Tech (ME)**  
**Semester: III**  
**Subject Code: UG11T4301**  
**Subject Name: Basic Control Engineering**

Date: 21.03.2025

Max Marks: 70

Duration: 03 Hrs

Pass Marks: 35

General Instructions

- (i) All Sections (A, B & C) are to be attempted.
- (ii) Options, if any, are specified in respective section.

**Section A**

**All questions are compulsory**

**(10 x 1 = 10 Marks )**

1. In Servo systems

- (A) Challenge is tracking of fast changing input
- (B) Input is constant
- (C) Challenge is disturbance rejection
- (D) No feedback exists

2. Offset

- (A) exists in PI control
- (B) is removed by adding Derivative control
- (C) is also known as Steady State Error
- (D) exists in PID control

3. Reset control means

- (A) Proportional Control
- (B) Integral Control
- (C) Derivative Control
- (D) On-Off Control

4. In PID control, tuning is done first for

- (A) P Controller
- (B) I Controller
- (C) D controller
- (D) Any of the controllers

5. Transfer Function uses

- (A) Z- transform                      (B) Fourier transform  
(C) Laplace transform              (D) Tustin transform

6. Laplace Transform of Unit Step Function is:

- (a) 1  
(b) s  
(c) 1/s  
(d) 2s

7. Order of the system of transfer function  $G(s) = 100 (s + 1) / (10s^2 + 5s + 3)$  is

- (A) 0                      (B) 1                      (C) 2                      (D) 3

8. Rise-time decides

- (A) Accuracy              (B) Speed              (C) Stability              (D) Offset

9. Elastic property of the material is used in

- (A) Bourdon gauge              (B) Diaphragm              (C) Bellows              (D) All of the above

10. A valve positioner:

- (a) Takes the place of a cascade control system  
(b) Provides more precise valve position  
(c) Makes a pneumatic controller in necessary  
(d) Provides a remote indication of valve position

### **Section B**

**All questions are compulsory**

**( 5 x 2 = 10 Marks )**

11. Define Accuracy and Stability.  
12. Can we use Derivative control alone? Justify your answer.  
13. Mention the names of various flow sensors  
14. What are the standard signal levels for Pneumatic transmitters and Electrical transmitters?  
15. What is the meaning of Fail-safe feature?

### **Section C**

**Answer any 5 questions**

**( 5 x 10 = 50 Marks )**

16. (a) Discuss the advantages and disadvantages of Closed loop control (4)

- (b) Explain On-Off Control with hysteresis (6)
17. (a) Explain PID Control (5)  
 (b) Explain Cascade Control (5)
18. (a) Explain the various delays (lags) in control systems? (5)  
 (b) Explain Control valve characteristics curves (5)
19. (a) Explain the various temperature sensors (6)  
 (b) Explain Nozzle Flapper with its characteristics (4)
20. Determine the transfer function  $[Y(s)/R(s)]$  for the block diagram shown in Fig. 1 (10 marks)

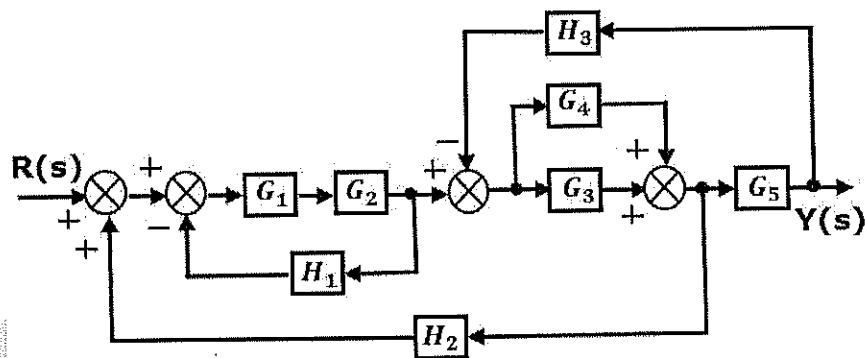
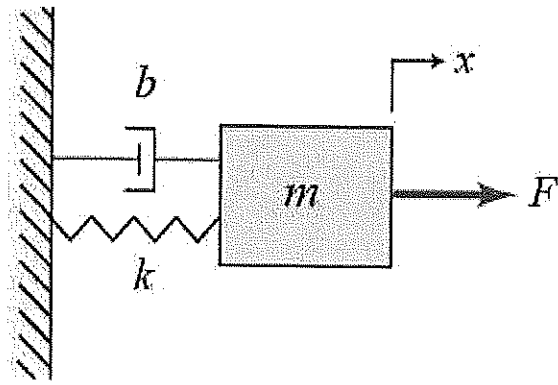

Fig. 1. Block diagram for a system

21. (a) Obtain the mathematical model of the following system where  $m$ =mass,  $k$ = spring,  $b$ = viscous friction,  $x$ =position output,  $F$ = force input (4)



(b) What are the essential requirements of UMS operation? (6)

22. Explain Fuel Oil Viscosity Control System with a neat diagram. (10)

\*\*\*\* END \*\*\*\*