

Data Sheet

Tank/Circulation Engine Heater

ZEROSTART
COLD WEATHER STARTING PRODUCTS

The newly designed automotive tank/circulation engine heater offers very dependable engine starts all winter long. By circulating warmed coolant through the engine, it assures fast defrost and heater action while greatly decreasing engine emissions associated with cold starts.

Standard Features

- Rugged diecast aluminum construction is corrosion and impact resistant.
- Copper heating element provides excellent heat transfer.
- Temperature sensing thermostat provides overheat protection.
- Temperature and oil resistant, permanently connected power cord with strain relief is flame retardant.
- Water resistant terminal end cap protects against harsh chemicals.
- Unique mounting system protects against road vibration.
- This lead-free heater utilizes recyclable aluminum, plastic and copper to help protect the environment.

Rugged Construction

Diecast aluminum construction

- Assures years of trouble free operation.
- Ensures corrosion and impact resistance.
- Eliminates leak points with one-piece construction.

Coolant tank designed to minimize trapped air in tank.

- Optimizes heat transfer process.
- Offers 750W-1500W with 5/8" (15.8 mm) and 2250W with 3/4" (19.0 mm) hose connections.
- Features beaded hose connections (SAE J1231) for positive seal.

Terminal Cap

- Provides road splash resistance.
- Resists high engine temperature.
- Resists typical engine fluids.

Water resistant terminal end cap

Permanent power cord with strain relief

Coolant outlet

Cast aluminum body

Coolant inlet

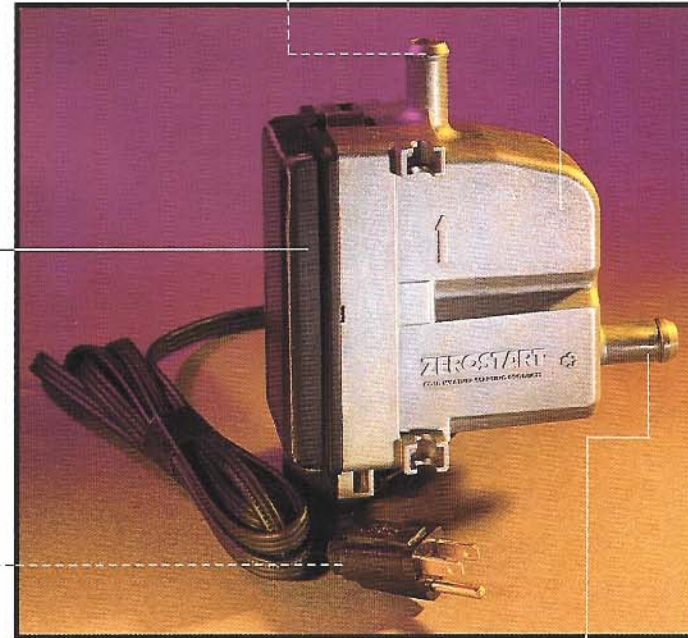

Copper Heating Element

- Provides better heat transfer than alternative materials.
- Improves heat transfer for maximum heater life.
- Utilizes unique 4-point securement for high vibration resistance.
- Features low watt density for increased heater life.
- Resistant to chlorine (present in many water supplies).

Power Cord

- Ensures safe, reliable operation in extreme temperatures.
- Contains flame retardant additives.
- Features oil resistant insulation.

Multi-Point Mounting

- Designed for easy installation
- Offers bottom, side, and top mounting options, with mounting kits.

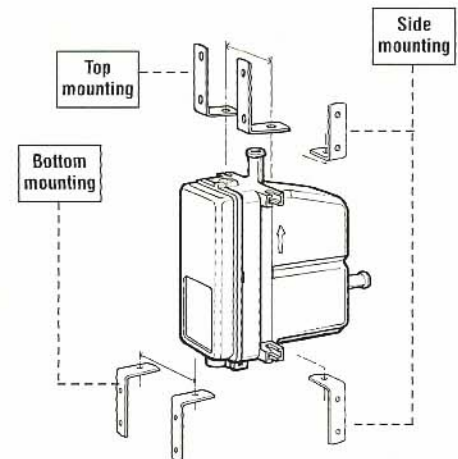

Part Number Data

Part No.	Watts	Voltage	Hose Connection Diameter
330-5001	750	120	5/8"
330-5002	1000	120	5/8"
330-5003	1500	120	5/8"
330-5004	2250	120	3/4"
330-5005	750	240	5/8"
330-5006	1000	240	5/8"
330-5007	1500	240	5/8"
330-5008	2250	240	3/4"

Heating Element Assembly

- 6 bolt with molded silicone seal for maximum sealing protection.

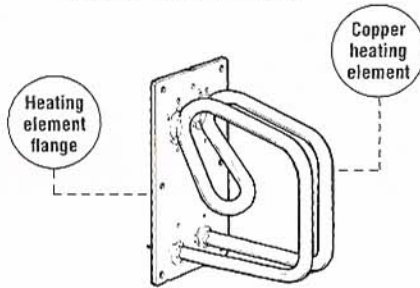

Tank Heater

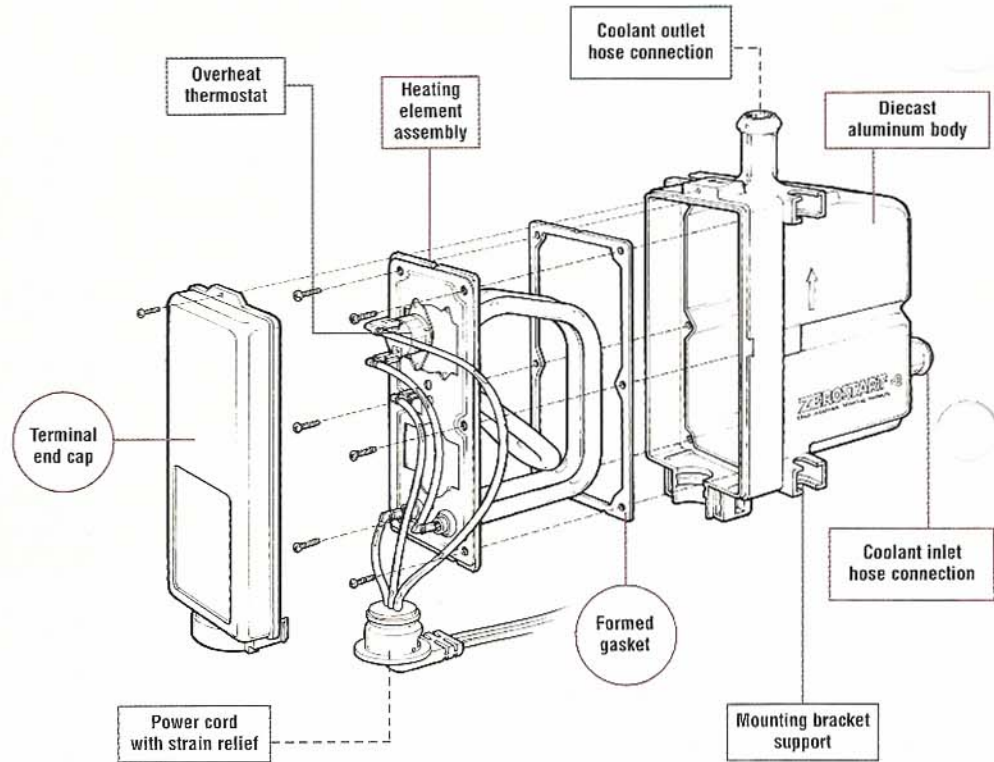

Temperature Rise Data

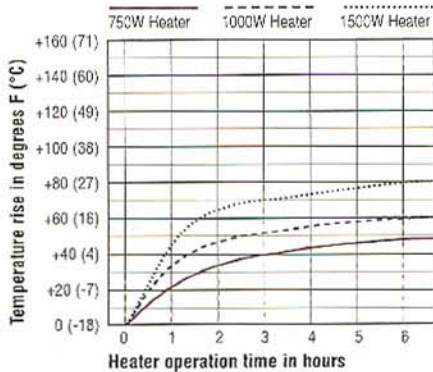

Overall Dimensions

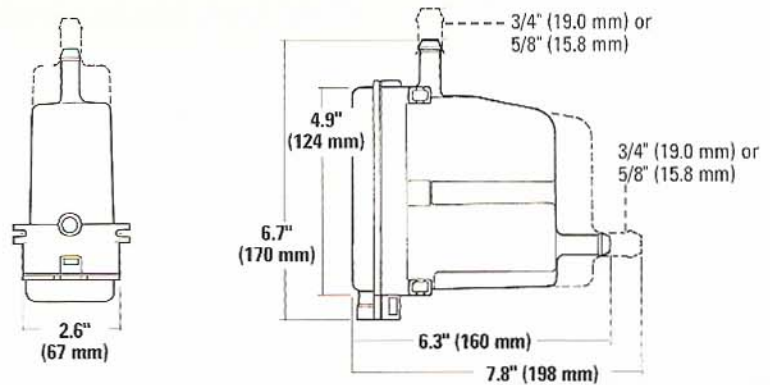

Overheat Thermostat

- Withstands overheating conditions without damaging heater or creating hazards.
- De-energizes heater in overheat condition to protect components.
- Measures temperature at heating element for quick response.
- Tested for 100,000 cycles.

Phillips and Temro Industries

Eden Prairie, Minnesota USA
800.328.6108 Fax: 612.941.2285

Winnipeg, Manitoba, CAN
800.665.0169 Fax: 204.667.2041



Approved to U.S. and Canadian standards.

Internet:
<http://www.phillipsandtemro.com>

E-mail:
Sales@zerostart.com

All specifications are subject to change without prior notice.