

		Date	06.01.1995	Customer				Customer Ref.		UTT 1952	
		Design	Sendler	Com. No.				Drawing No.		LA3-M3000-01	
REV. 01		19.05.2006	Fritzen	Check						Page 1	
Status	Revision	Date	Name	Norm	Org.	Data	vbatch1			from	4 Bl.

**LINDENBERG-ANLAGEN**  
Auf der Gröfenfurth 25-27  
 D-51603 Rietzsch  
 Tel.: +49 (0)2205/8009-0  
 Fax: +49 (0)2205/8009-109  
 www.Lindenberg-Anlagen.de

**BATTERY CHARGER  
 WITH ALARM UNIT**

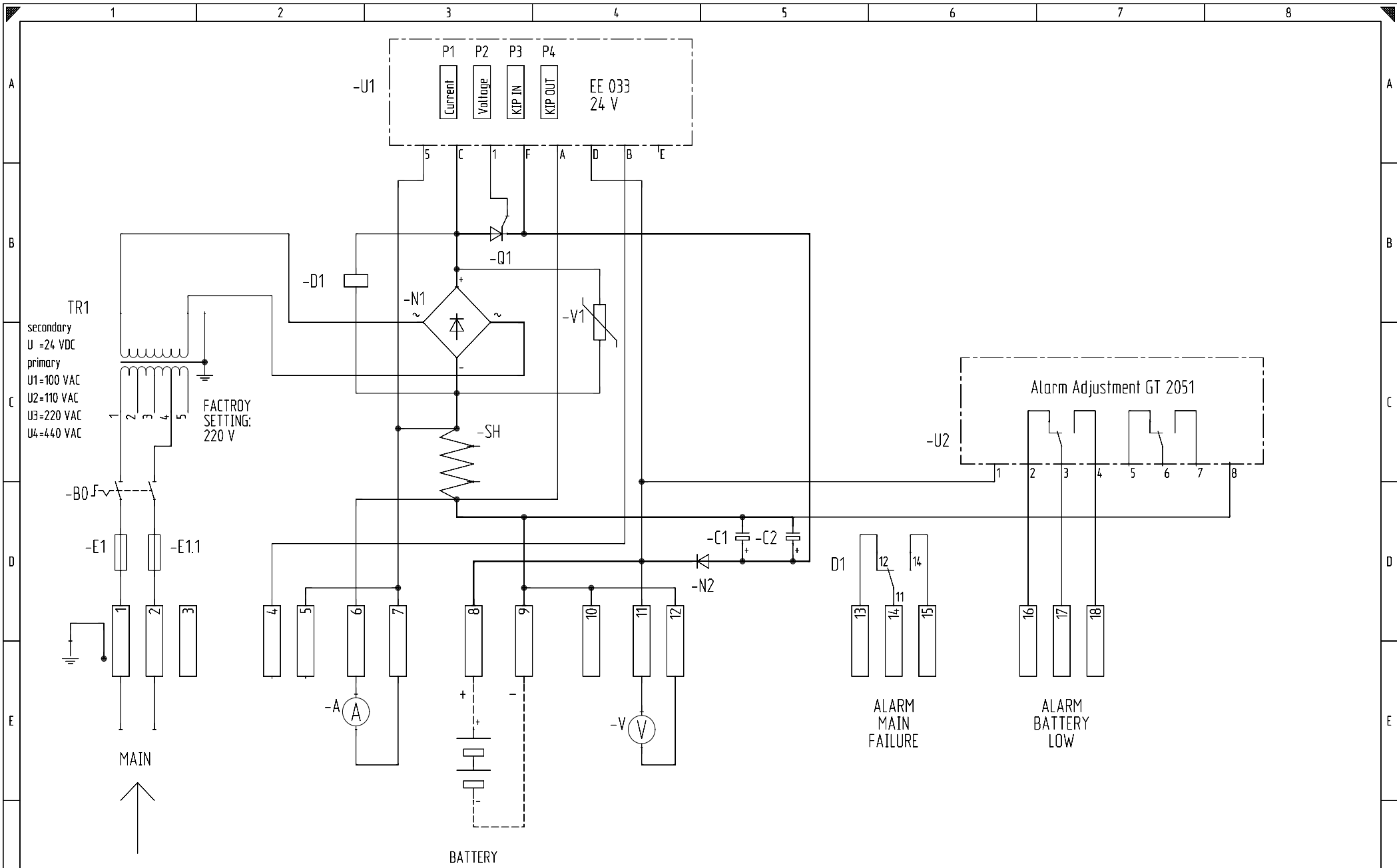



		Date	06.01.1995	Customer					
		Design	Sendler	Com. No.					
REV. 01		19.05.2006	Fritzen	Check					
Status	Revision	Date	Name	Norm	Org.	Data	vbatlch1		
						Auf der Gröfenfurth 25-27 D-51603 Rietzsch Tel.: +49 (0)2205/8009-0 Fax: +49 (0)2205/8009-109 www.Lindenberg-Anlagen.de		BATTERY CHARGER WITH ALARM UNIT	
				Customer Ref.		UTT 1952			
				Drawing No.		LA3-M3000-01		Page 3	
								from 4 Bl.	

CONNECTION X1

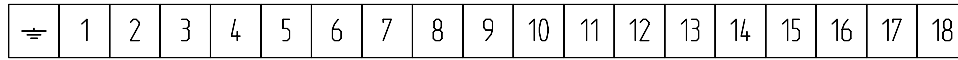

MAIN POWER

BATTERY

MAIN POWER FAILURE ALARM

BATTERY LOW ALARM

CONNECTION MULTITRANSFORMER

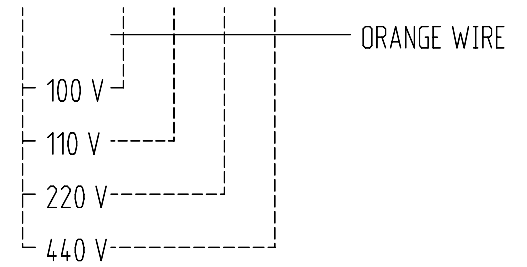
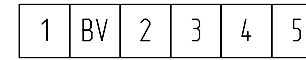

!! CAUTION !!

FACTORY SETTING IS 220 V.  
MOVE THE ORANGE CABLE TO CHANGE THE SETTING

		Date	06.01.1995	Customer				LINDENBERG-ANLAGEN		BATTERY CHARGER WITH ALARM UNIT	Customer Ref.	UTT 1952	=	
		Design	Sendler					 Auf der Gröfenfurth 25-27 D-51603 Rietzsch Tel.: +49 (0)2205/8009-0 Fax: +49 (0)2205/8009-109 www.Lindenberg-Anlagen.de					+	
REV. 01		19.05.2006	Fritzen	Check							Drawing No.	LA3-M3000-01	Page 4	
Status	Revision	Date	Name	Norm	Org.	Data	vbatlch1					from	4 Bl.	

# DESCRIPTION BATTERY CHARGER -IP44-

---

<b>Contents:</b>	<b>1.</b>	<b>General Description</b>
	<b>2.</b>	<b>Data</b>
	<b>3.</b>	<b>Adjustment</b>
	<b>4.</b>	<b>Operation Instructions</b>

## **1. GENERAL DESCRIPTION**

The battery charger (according EN60529/IEC529-IP44) is constructed with main transformers with separate windings, which are vacuum coated. On the secondary side of the transformers the alternative voltage is rectified by an enclosed silicon bridge rectifier. The current and voltage are thyristors regulated.

The charging voltage is already individually adjusted at the factory for every battery type, but can easily be readjusted on the distinctly marked (P2) potentiometers inside. Also the current limitation is factory adjusted, but are easily readjusted on potentiometers marked P1.

The chargers advanced electronics ensure a quick and accurate charging of the battery and include thyristor trigger circuit and the voltage and current stabilisers on the printed circuit board EE033.

The charger is a constant voltage charger with electronic current limitation. The current limitation ensures that the charging current cannot be forced above the level adjusted at the factory.

This means that an arbitrary high current can be drawn from the battery without that the parallel working charger being overloaded.

The charger is equipped with \*soft start\*, whereby terminals plough outlets or contractors are protected against sparking action.

The above equipment can be fitted with a filter which ensures a low ripple value. Voltage stabilisation can be achieved by an operational amplifier sensing the output voltage level.

Optional an alarm system can be installed.

An alarm will be given if there is a charger failure or if the phase is missing.

The electronic for boost charging is activated automatically if the voltage levels on the rectifier terminals falls below num. volts DC. (May be adjusted P3, P4).

The adjustment setting can be varied but should normally be closed to U (trickle charge) -10% to avoid interference with other voltage settings.

When starting with boost charging in one of the ways mentioned above the boost charging will run until the voltage on the battery terminals reach U (trickle charge) +10% and then stop, bringing the voltage level to a normal charging level of U trickle charge.

## 2. Data:

Input voltage	: (110-550 V.) 60/50 Hz.
Output voltage	: 12 V. - 220 V.
Factory adjusted voltage	: 2,22 V. per cell 26,6 V.
Boost charging voltage low level	: 1,9 V. per Pb cell
Boost charging voltage high level	: 2,4 V. per Pb cell
Regulation	: Better than +/- 1,5% for +/- 10% mains variation Better than +/- 1,5% for 10-90% load
In accordance with	: DIN41773, DIN57820, VDE 051011.77, DEFU 9.77.

## 3. ADJUSTMENT

### **The charger:**

To avoid interference with the boost disconnect the wire to pin number B on the connector to the printed circuit board EE033 and make a short circuit between B and E on the same connector.

The **charging voltage** is adjusted at potentiometer P2 on the printed circuit board. The level is set to 2,22 V per Pb cell at the factory. A higher setting can be obtained by turning the potentiometer clockwise and a lower setting by turning counter clockwise.

The **charging current** is adjusted on potentiometer P1 on the printed circuit board. The level is set to I nom. at the factory. A higher setting can be obtained by turning the potentiometer clockwise and lower setting by turning counter clockwise.

Please **remember** to connect the wires to their original position.

### **The boost charging:**

Connect a DC voltage-meter RANGE 20V. with the minus at the battery (terminal 9) and the plus to the test point TPI on printed circuit board EE033.

When the meter shows 10V. the boost charging is activated and below 5V. deactivated.

**First** of all adjust the activating level on potentiometer P3. The level is set to U trickle charge - 10% at the factory.

A higher set can be obtained by turning the potentiometer clockwise and a lower setting by turning counter clockwise. The stop of the boost charging is adjusted on Potentiometer P4. The level is set to U trickle charge +10% at the factory; a higher setting can be obtained by turning the potentiometer counter clockwise and a lower setting by turning clockwise.

#### **4. Operation instructions:**

- a. Check that mains voltage is in accordance with the nameplate
- b. Check that the battery type and the cell numbers are in accordance with the indications on the nameplate.
- c. Connect the charger to the mains.
- d. Connect the battery on the + and - terminal screws with correct polarity. The DC Voltmeter should now show the battery-voltage.
- e. Close the main switch. DC ammeters should now show the charging current. If the battery is fully charged and at no load, the charging current may be very low.
- f. The charger is now functioning and attending is necessary.
- g. If the charger does not give any charging current even when load is drawn from the battery, then check the fuse, the main voltage and the battery connection.
- h. Should the charger for any reason have been brought out of adjustment, consult the special manual for adjustment of electronic system and other parts.

#### **Lindenberg-Anlagen GmbH**

Auf der Grefenfurth 23-25

51503 Rösrath-Kleineichen

Germany Tel.: +49-2205-8009-0

Fax: +49-2205-8009-109

E-mail: [lindenberg-anlagen@t-online.de](mailto:lindenberg-anlagen@t-online.de)

Rösrath, May 2000