

---

**Indian Maritime University**  
**(A Central University, Govt of India)**

**Mar/Apr'26 SE**

**Programme Name: B Tech (Marine Engineering)**

**Semester: II**

**Subject Code: UG11T5204**

**Subject Name: Engineering Mechanics**

---

Date: 14.03.2026

Max Marks: 70

Duration: 03 Hrs

Pass Marks: 35

---

General Instructions

- (i) All Sections (A, B & C) are to be attempted.
- (ii) Options, if any, are specified in respective section.

**Section A**

Ten MCQs/Fill in the Blanks of 01 Mark each – Choose the correct answer as applicable.

1. Which of the following is the basic law for mechanics?
  - a) Newton's law of viscosity
  - b) Parallelogram law
  - c) Newton's laws of motion
  - d) Hooke's law
2. When can two forces be in equilibrium?
  - a) They are equal in magnitude
  - b) They are collinear
  - c) They are opposite in direction
  - d) All of the mentioned
3. What is the relationship between each force, if three concurrent forces acting on a body according to Lami's theorem?
  - a) Directly proportional to the sine of the angle between the other two forces
  - b) Inversely proportional to the cosine of the angle between the other two forces
  - c) Directly proportional to the cosine of the angle between the other two forces
  - d) Inversely proportional to the sine of the angle between the other two forces

---

4. If the sum of all the forces acting on a body is zero, then it may be concluded that the body

- a) must be in equilibrium.
- b) may be in equilibrium
- c) may be in equilibrium provided that the forces are concurrent
- d) may be in equilibrium provided that the forces are parallel.

5. A car which is moving along a straight road starts retarding after the brakes are applied. Then the direction of inertia force will be

- a) forward
- b) backward
- c) both a & b
- d) None

6. The centre of gravity is the ratio of \_\_\_\_\_ to \_\_\_\_\_

- a) The product of centroid and weight to the total weight
- b) The addition of centroid and weight to the total weight
- c) The subtraction of centroid and weight to the total weight
- d) The product of centroid and weight to the total mass

7. Which of the following is a feature of friction?

- a) Always acts in the direction opposite to the applied force
- b) Not a self-adjusting force
- c) Always acts in the direction of applied force
- d) It is an active force

8. The product of area and the square of the distance of centre of gravity of the area from the axis is

- a) Second moment of mass
- b) Second moment of area
- c) first moment of area
- d) Mass moment of inertia

9. The time of flight of a projectile on the downward inclined plane depends on

- a). Angle of Projection
- b). Angle of inclination of the plane
- c). Both (a) and (b)
- d). None of These

10. The forces, which meet at one point, but their lines of action do not lie in a plane, are called

- A. Coplanar non-concurrent forces
  - B. Non-coplanar concurrent forces
  - C. Non-coplanar non-concurrent forces
  - D. Intersecting forces
-

---

### Section B

Five Questions of 02 Marks each

11. Define parallelogram law of forces
12. Define angle of repose
13. State parallel axis theorem.
14. Define D'Alembert's Principle
15. What is projectile motion?

### Section C

Seven Questions of 10 Marks each of which any 05 questions to be answered.

16. Five forces are acting on a particle. The magnitude of the forces are 300N, 600N, 700N, 900N and P and their respective angles with the horizontal are  $0^\circ$ ,  $60^\circ$ ,  $135^\circ$ ,  $210^\circ$  and  $270^\circ$ . If the vertical components of the forces is  $-1000\text{N}$ , find the value of the P. Also calculate the magnitude and the direction of the resultant, assuming that the first force acts towards the point, while all the remaining forces act away from the point.

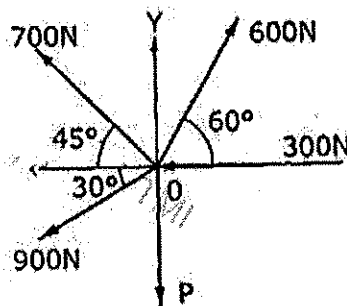

17. What should be the value of the angle  $\theta$  so that motion of the 390N block impends down the plane. The co-efficient of friction for all the surfaces is  $1/3$ .

TMI

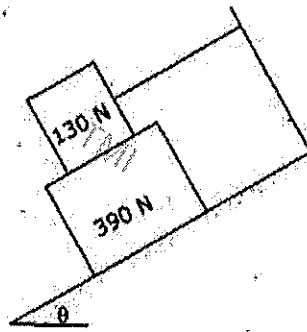

18. Locate the centroid of the sectioned area shown in the figure.

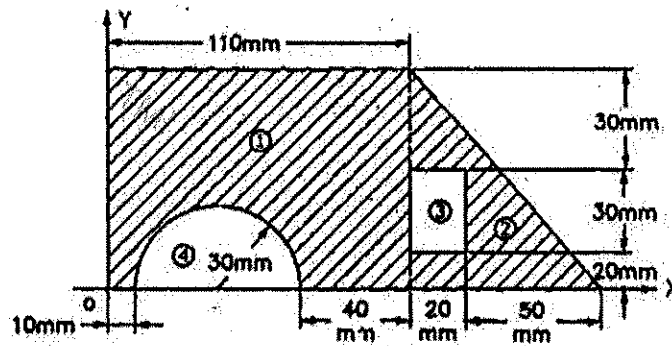

TMI

19. Find the moment of inertia of an unsymmetrical I section shown in Figure. About its centroidal axes.

TMI

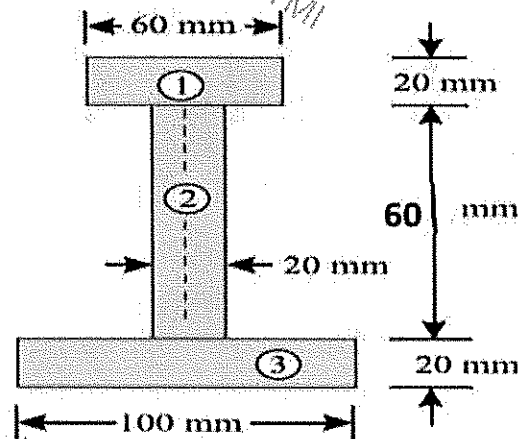

TMI

TMI

---

20. The equation of motion of a particle moving in a straight line with variable acceleration is given by,  $S = 15t + 3t^2 - t^3$  in which, 's' is the distance measured in 'm' and the time 't' is measured in seconds. Calculate (i) the velocity and acceleration at start, (ii) the time at which the particle attains its maximum velocity, (iii) the maximum velocity of the particle

21. Two weights 80 N and 20 N are connected by a thread and move along a rough horizontal plane under the action of a force 40N, applied to the first weight of 80 N as shown in figure. The coefficient of friction between the sliding surfaces of the weights and the plane is 0.3. Design the acceleration of the weights and the tension in the thread using D'Alembert's Principle.

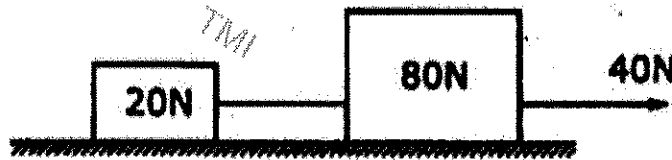

22. The guns are pointed at each other, one upward at an angle of elevation of  $30^\circ$  and the other at the same angle of depression, the point of projections being 30 meters apart. If the guns are shot with velocities of 350 m/s upwards and 300 m/s downwards respectively, find when and where they will meet. Take  $g = 9.8 \text{ m/s}^2$ .

