

Indian Maritime University
(A Central University, Govt of India)

Sep/Oct'25 SE

Programme Name: B Tech (ME)

Subject Code: UG11T4401

Subject Name: STRENGTH OF MATERIALS

Date: 25.09.2025	Max Marks: 70
Duration: 03 Hrs	Pass Marks: 35

General Instructions

- (i) All Sections (A, B & C) are to be attempted.
- (ii) Options, if any, are specified in respective section.

Section A

Ten MCQs/Fill in the Blanks of 01 Mark each – Choose the correct answer as applicable.

1. A triangular load over a beam span produces a Shear Force diagram that is:

- (A) Linear
- (B) Parabolic
- (C) Cubic
- (D) Constant

2. If the depth of a rectangular beam is doubled while keeping the same width, the maximum bending stress will:

- a) Double
- b) Reduce to half
- c) Reduce to one-fourth
- d) Remain the same

3. The neutral axis of a beam is the axis at which:

- a) Maximum bending stress occurs
- b) Zero bending stress occurs
- c) Maximum shear stress occurs
- d) Maximum strain occurs

4. In a simply supported beam subjected to a uniformly distributed load, the number of points of contraflexure is:

- a) Zero
- b) One
- c) Two
- d) Infinite

5. Why is Macaulay's Method preferred over direct integration methods for solving beam deflection?

- a) It avoids separate equations for different sections of the beam
- b) It provides exact solutions for indeterminate structures
- c) It simplifies the calculation of reaction forces
- d) It does not require the use of boundary conditions

6. According to Mohr's Second Theorem, deflection at a point is proportional to:

- a) Flexural rigidity
- b) Area of the shear force diagram
- c) Moment of the area of the bending moment diagram
- d) None of the above

7. For which type of structure is the Theorem of Three Moments NOT suitable?

- a) Beam with continuous supports
- b) Hinged beam structures
- c) Simply supported beams without continuity
- d) Multi-span continuous beams

8. In a cantilever beam under a point load at the free end, the maximum strain energy is stored at:

- a) The free end
- b) The fixed support
- c) The mid-point
- d) Uniformly throughout the beam

9. According to Castigliano's First Theorem, the deflection at any point in a structure is given by which of the following?

- a) The total strain energy of the structure
- b) The derivative of the strain energy with respect to the applied moment
- c) The integral of the bending moment squared divided by EI
- d) The derivative of the strain energy with respect to the applied force at that point

10. If the radius of gyration k of a column increases while keeping the effective length L_e constant, how does the slenderness ratio change?

- a) It increases.
- b) It decreases.
- c) It remains the same.
- d) It first increases, then decreases.

Section B

Five Questions of 02 Marks each

11. A cantilever of length 2 metre fails when a load of 2 kN is applied at the free end. If the section of the beam is 40 mm × 60 mm, find the stress at the failure.
12. What is the effect of a couple on the Bending Moment diagram at the point of application? Explain with diagram.
13. Define Claperyon's three moment theorem
14. Write the assumptions made in Euler's theory.
15. Write the theoretical difference between short and long column.

Section C

Seven Questions of 10 Marks each of which any 05 questions to be answered.

16. Draw the Shear Force (S.F.) and Bending Moment (B.M.) diagrams for the overhanging beam carrying a uniformly distributed load (u.d.l.) of 2 kN/m over the entire length and a point load of 2 kN, as shown in Fig. Locate the point of contraflexure. **(10 Marks)**

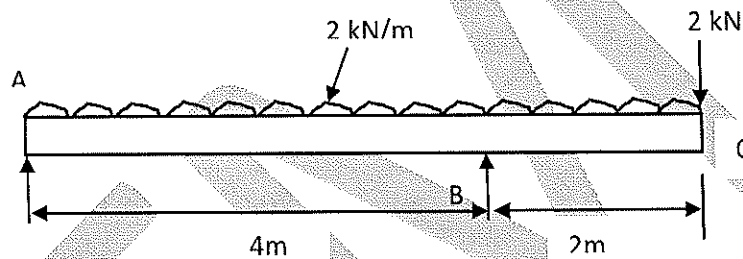

17. A simply supported beam of length 3 m carries a point load of 12 kN at a distance of 2 m from the left support. The cross-section of the beam is shown in Fig.. Determine the maximum tensile and compressive stress at X-X. **(10 Marks)**

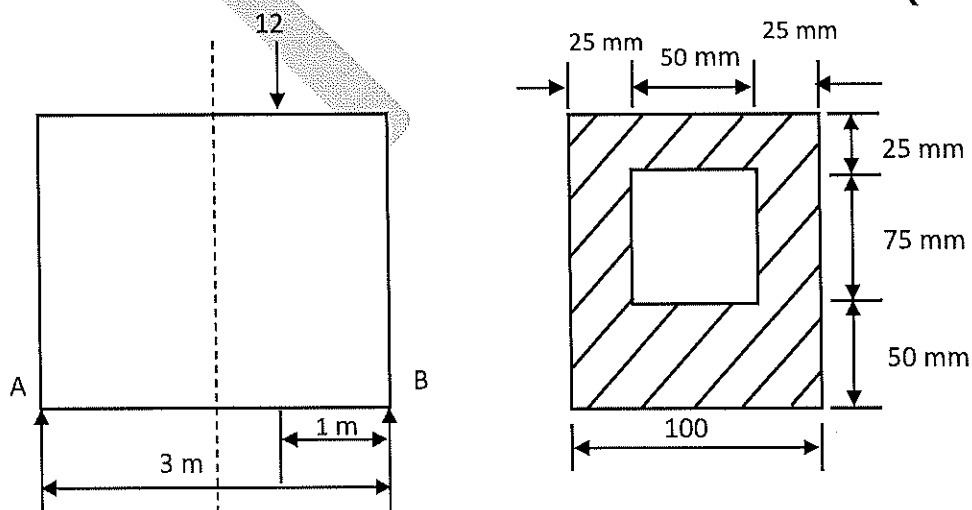

18. An overhanging beam ABC is loaded as shown in the figure below. Find the slopes over each support and at the right end. Find also the maximum upward deflection between the supports and the deflection at the right end.

Take $E = 2 \times 10^5 \text{ N/mm}^2$ and $I = 5 \times 10^8 \text{ mm}^4$. **(10 Marks)**

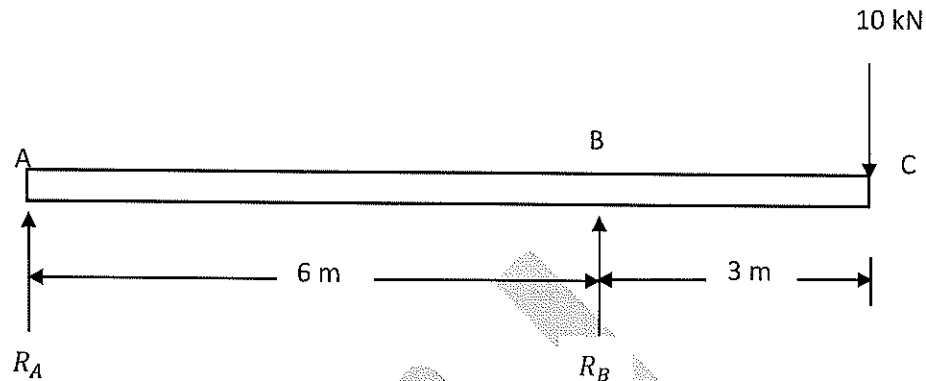

19. (a) Determine the slope and deflection of a cantilever at point B with a uniformly distributed load for a distance 'a' from the free end (as shown in the figure)

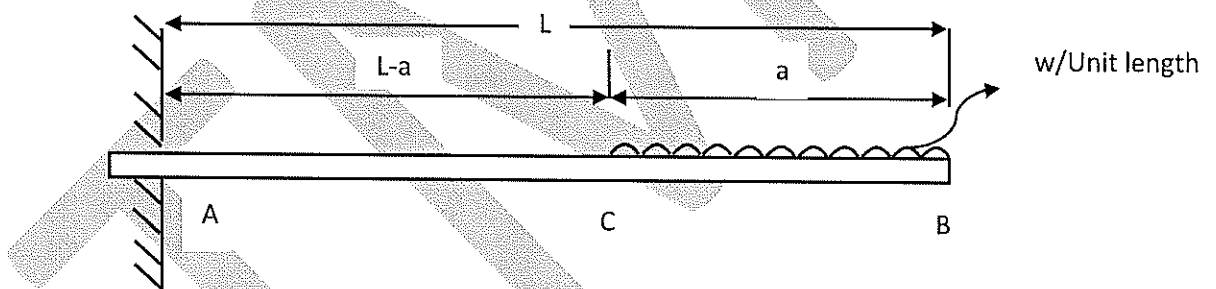

- (b) Determine the maximum slope and deflection of a cantilever with a uniformly distributed load by moment-area method.

(5+5 Marks)

20. A continuous beam ABCD of length 15 m rests on four supports covering 3 equal spans and carries a uniformly distributed load of 1.5 kN/m length. Calculate the moments and reactions at the supports. Draw the S.F. and B.M. diagrams also. **(10 Marks)**

21. (a) Calculate the Euler's critical load for a strut of T-section, the flange width being 10 cm, overall depth 8 cm and both flange and stem 1 cm thick. The strut is 3 m long and is built in at both ends. Take $E = 2 \times 10^5 \text{ N/mm}^2$.

- (b) Explain Rankine-Gordan Formula.

(7+3 Marks)

22. (a) Briefly explain Castigliano's Theorem

(b) Using the modified form of Castigliano's theorem, obtain the deflection under a single concentrated load applied to a simply supported beam as shown in Fig.

(3+7 Marks)

