

Indian Maritime University
(A Central University, Govt of India)

Sep/Oct'25 SE

Programme Name: B Tech (ME)

Semester: II

Subject Code: UG11T5204

Subject Name: Engineering Mechanics

Date: 11.09.2025	Max Marks: 70
Duration: 03 Hrs	Pass Marks: 35

General Instructions

- (i) All Sections (A, B & C) are to be attempted.
- (ii) Options, if any, are specified in respective section.

Section A

Ten MCQs/Fill in the Blanks of 01 Mark each – Choose the correct answer as applicable.

1. The forces which meet at one point, but their lines of action do not lie in a plane are called
 - A. Coplanar non- concurrent forces
 - B. Non- Coplanar concurrent forces
 - C. Non- coplanar, non-concurrent forces
 - D. Intersecting forces
2. The angle between two forces when the resultant is maximum and minimum respectively are
 - A. 0° and 180°
 - B. 180° and 0°
 - C. 90° and 180°
 - D. 90° and 0°
3. Varignon's theorem of moments states that if a number of coplanar forces acting on a particle are in equilibrium, then
 - A. Their algebraic sum is zero
 - B. Their lines of action are at equal distances

- C. The algebraic sum of their moments about any point in their plane is zero
- D. The algebraic sum of their moment about any point is equal to the moment of their resultant force about the same point.
4. Moment of inertia of a triangle about centroidal axis parallel to the base
- A. $\frac{bh^3}{36}$ B. $\frac{bh^3}{12}$ C. $\frac{bh^3}{3}$ D. $\frac{bh^3}{18}$
5. Centre of gravity of solid cone lies on the axis at the height of (from base)
- A. $\frac{H}{4}$ B. $\frac{H}{3}$ C. $\frac{2H}{3}$ D. $\frac{H}{2}$
6. Which of the following is a vector quantity?
- A. Speed B. Mass C. Force D. Energy
7. Which of the following is true for an object in equilibrium?
- A. The net force acting on the object is zero
- B. The object is always at rest
- C. The net moment is infinite
- D. The object is always moving at a constant speed
8. In projectile motion, the horizontal component of velocity:
- A. Increases with time B. Decreases with time
- C. Remains constant D. Becomes zero at the highest point
9. At the highest point of the projectile's trajectory, the velocity is:
- A. Zero B. Horizontal C. Vertical D. Maximum
10. Which of the following statements best describes D'Alembert's Principle?
- A. The sum of external forces equals the mass times acceleration.
- B. The sum of forces, including inertial forces, is zero in a dynamic system.
- C. The sum of internal forces equals the acceleration of the system.
- D. The system remains at rest under the action of the applied forces.

Section B

Five Questions of 02 Marks each

11. What is dry friction or Coulomb friction?
12. What is a centroid?
13. Define Vector and Scalar.

14. What is a rigid body? Define static equilibrium.
 15. Define trajectory of a projectile motion.

Section C

Seven Questions of 10 Marks each of which any 05 questions to be answered.

16. (i) Explain with a neat sketch, principle of transmissibility of a force. (4)
 (ii) State triangle law for addition of vectors. (3)
 (iii) State law of parallelogram of vectors. (3)

17. Replace the 1000 N force shown in Figure by two forces, a 500 N force acting in the negative Y direction and a force \vec{F} , which together are equivalent to the action of the 1000 N force. Find the magnitude of \vec{F} and the angle α that it makes with the Y axis.

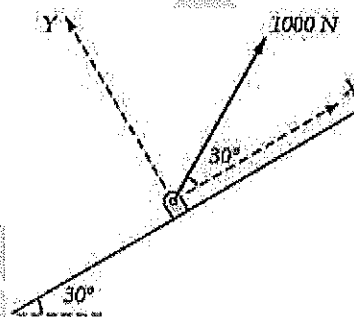

18. Replace the force and couple acting on the rectangular plate shown in Figure by two forces - a horizontal force at B and another force at D.

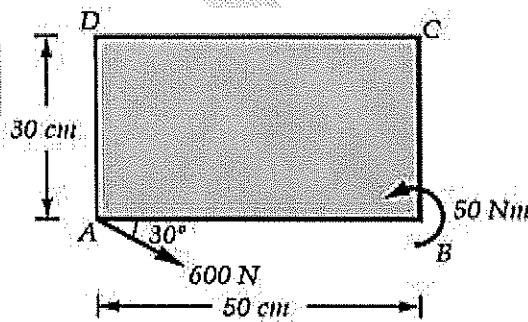

19. (i) A body of weight 300 N is kept on a rough horizontal plane and a force P is applied to just move the body horizontally as shown in Figure. Find the magnitude of force P required if coefficient of static friction is $\mu_s = 0.4$. (5)

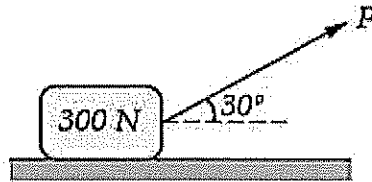

(ii) A ladder AB weighing 196 N is resting against a rough wall and a rough floor, as shown in Figure. Calculate the minimum horizontal force 'P' required to be applied at C in order to push the ladder towards the wall. Assume coefficient of friction at A = 0.3 and that B = 0.2. (5)

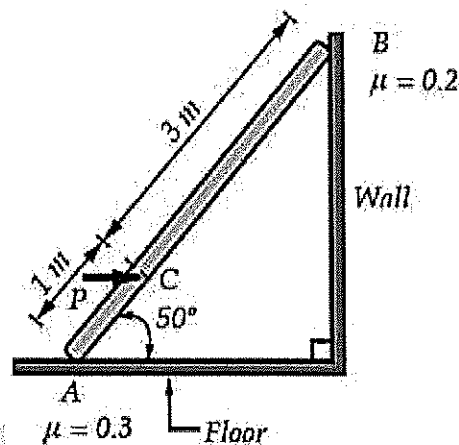

20. A semi-circular area is cut from a trapezium as shown in Figure. Determine the centroid of the shaded portion with respect to the origin.

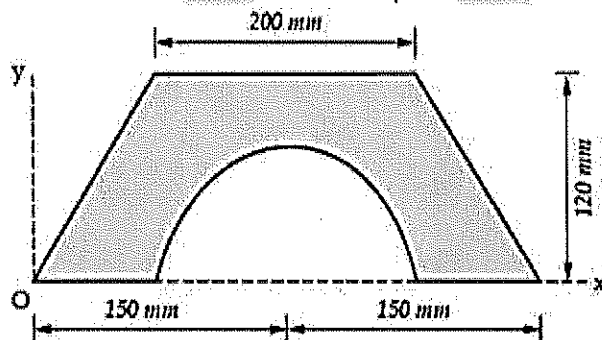

21. In a flood relief area, a helicopter going up with constant velocity drops a food packet, which takes 4 seconds to reach ground. No sooner than the first packet reaches the ground, second packet was released, which takes 5 seconds to reach ground. From what height the first packet was released? Also find the constant, upward velocity of helicopter.

22. (i) The velocity of a particle moving in x-y plane is given by $\vec{v} = 3\hat{i} - 2\hat{j}$ m/sec at $t = 2$ s. Its average acceleration during the next 2 s is $\hat{i} + 2\hat{j}$ m/sec². Determine

the velocity at $t = 4\text{s}$ and the angle between the average acceleration vector and the velocity vector at $t = 4\text{s}$? (5)

(ii) A plane flying horizontally at 500 km/hr releases a bomb at an elevation of 1200 m from ground. Write vector equations for velocity and position of the bomb at any time ' t ' seconds after release. Hence find the time when the bomb will strike the ground. Use point of release as the origin. (5)

T M M

