

# SERVICE INSTRUCTIONS

<b>CONTENTS</b>	<b>Information</b>	<b>Spare Parts</b>
Introduction	1	----
Approved hydraulic fluids and greases	1	----
Safety precautions	2	----
Working principles & operating instructions	3	----
Servicing	5	----
Starter Unit	5	17
Hand Pump & Pressure Gauge	8	19
Relay Valve	10	20
Accumulator	10	21
Filling and Venting the System	10	----
Pipe Connections	11	22
Routine Maintenance	12	----
Trouble Shooting	13	----

## INTRODUCTION

This handbook is provided to help the operator to obtain the best service from the Prestolite Handraulic Starter. Normally the starter is “trouble free”, but damage or unusual conditions of service may necessitate examination of the system for faults. After long service it may be necessary to replace worn parts.

The letter G in the starter unit typecode i.e. B50G53 identifies the direction of rotation, and indicates suitability for engines having clockwise rotation of the crankshaft viewed from the free end.

Please quote the unit typecode and component part number when ordering spare parts.

Only use genuine Prestolite Parts and approved Hydraulic Fluids and greases in the starter installation. The use of spurious parts or incorrect fluids may cause failures, and will invalidate claims arising from their use.

### **Approved Hydraulic Fluids and Lubricating Greases:**

For operation in temperatures below  $-10^{\circ}$  only fluids conforming to specification OM15 are suitable, and the following brands are approved: Prestolite only supply fluid conforming to specification OM15.

Castrolareo 585B  
BP Aero Hydraulic 1B  
Shell Areoshell 41

Esso Univas FJ13  
Mobil Aero HFE

Lubricating Grease

Shell Alvania RA.R2

For operation in temperatures above  $-10^{\circ}$  fluids conforming to specification OM13 and OM15 are suitable. The following brands conforming to specification OM13 are approved:

Castrol Hyspin AWS15  
BP Energol HLP15  
Esso Nuto H15

Mobil DTE21  
Shell Tellus T15

Lubricating grease,

Shell Alvania RA, R2  
Castrol Spheerol MP2, L-EP2

**Figure 1 Prestolite Handraulic Starter System Layout**

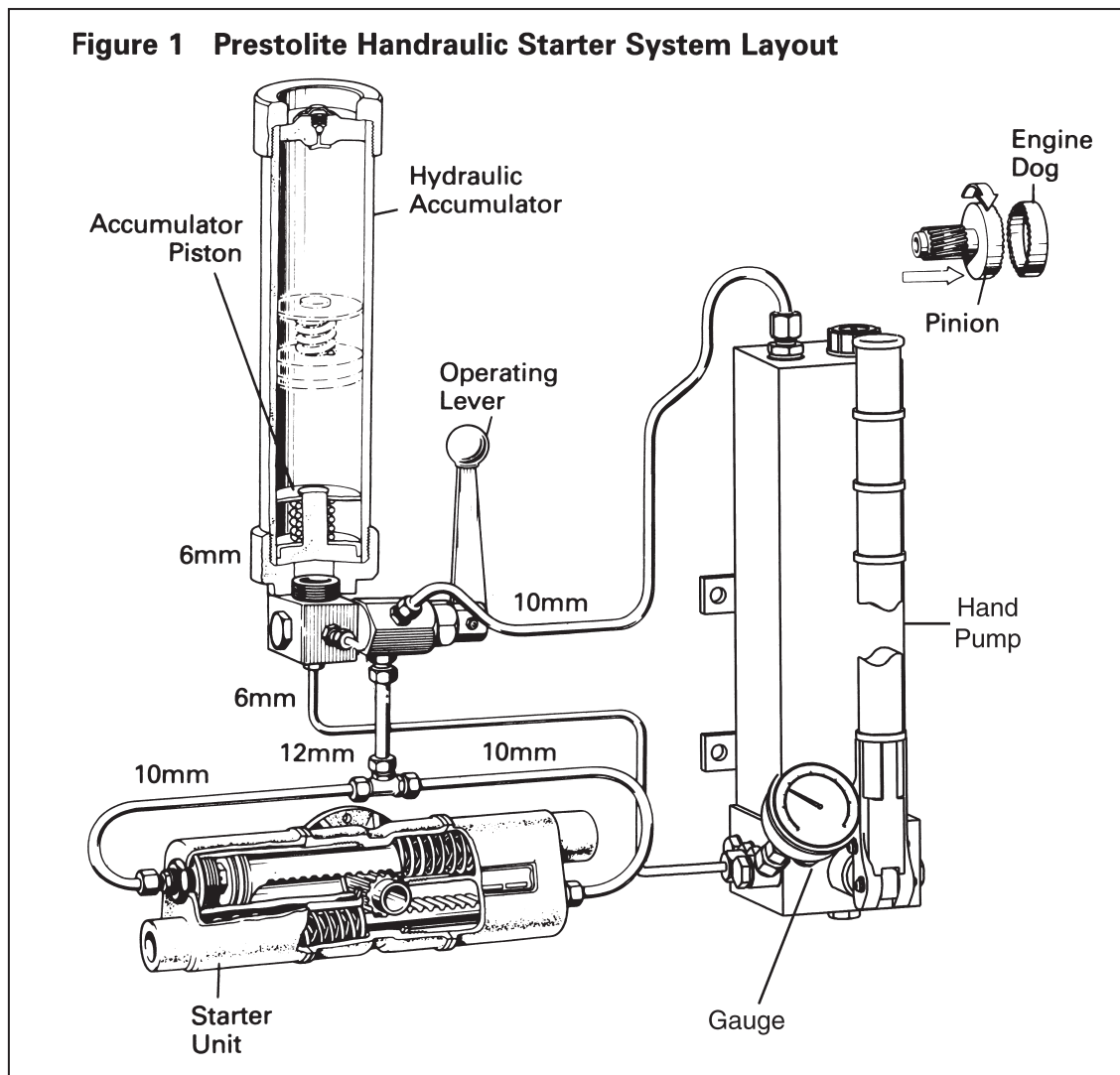

## **SAFETY**

Detailed notes are included in the operating and service instructions where appropriate, and are summarised below.

### **SAFETY PRECAUTIONS**

- 1. Do not disconnect pipe joints with the system under pressure. Discharge the accumulator first by operating the relay valve.**
- 2. Do not operate the starter unless the starter unit is secured to its mounting bracket on the engine. During starting the starter pinion is fed forward and rotated at high speed, and the engagement teeth can inflict severe injury.**
- 3. Do not remove spring retaining nuts, circlips or other retainers without first ensuring that the spring is prevented from releasing suddenly.**
- 4. Do not attempt to dismantle nor flame cut the accumulator. It is permanently charged with nitrogen gas at high pressure.**
- 5. If the accumulator is to be scrapped, follow the guidelines as described on page 19.**
- 6. Do not use lubricating oil or vegetable based oil (such as automobile brake fluid). Use only the hydraulic fluids recommended on page 1.**

## WORKING PRINCIPLES AND OPERATING INSTRUCTIONS

The Prestolite Handraulic Starter system is shown in Figure 1, and uses a combination of pneumatic and hydraulic principles to store and release energy for engine starting.

The essential units are: -

Feed Tank / Hand Pump	Hydraulic Accumulator
Pressure Gauge	Relay Valve
Starter Unit	Engine Dog

Connected by high-pressure tubing.

The Starter Unit is attached to the free end of the engine by a mounting bracket, and the engine dog is attached to the crankshaft using a suitable adapter.

The heart of the starter is the Hydraulic Accumulator, which comprises a cylinder closed at each end, in which a leak-proof piston is free to slide. Above the piston the cylinder is pre-charged with nitrogen to a pressure of approximately 200 bar (2900lbf/in<sup>2</sup>) and permanently sealed. Under these conditions the piston rests at the base of the cylinder.

By operating the Hand Pump, hydraulic fluid is drawn from the feed tank and pumped into the Accumulator below the piston until the piston has been displaced sufficiently to raise the nitrogen and fluid pressure to approximately 310 bar (4500 lbf/in<sup>2</sup>).

The Starter Unit incorporates two opposed cylinders, each containing a rack in mesh with a common pinion. This pinion has face teeth at one end; during starting this drives a dog having corresponding teeth, which is attached to the engine crankshaft.

Two helical grooves formed in the periphery of the pinion are engaged by spring loaded balls incorporated in the starter housing; these impart a forward axial movement to the pinion to effect its engagement with the engine dog, positive engagement being maintained by the helical tooth-form of the pinion and racks.

Operation of the Relay Valve lever admits hydraulic fluid at high pressure to the Starter Unit racks, bringing the pinion into engagement with the engine dog and imparting a high rotational speed to the engine crankshaft.

## OPERATING INSTRUCTIONS

First ensure that the engine is in a ready-to-start condition, primed with fuel and at full compression. If the engine has not been started since leaving the manufacturers works check the Starter and Engine for freedom as described on page 13.

Check that the Feed Tank is filled to the correct level with approved hydraulic fluid and vented as described on page 10 "**Filling and Venting the System**". Raise pressure to between 276 and 345 bar (4000-5000 lbf/in<sup>2</sup>) using the Hand Pump. Pull the Relay Valve operating lever until resistance is felt (about 45°), then continue until the lever has reached its stop.

The Relay Valve lever operates a two-stage valve, and should not be snatched or jerked.

The first stage allows a slow bleed of pressurised fluid to the starter racks, causing slow rotation of the starter pinion accompanied by its forward axial movement until it is engaged with the engine dog.

The second stage releases the full flow of fluid at high pressure to the racks; this provides the starting impulse.

When the engine starts, the lever is released to return to its normal position. Springs return the racks to their original position and the pinion retracts. Fluid from the starter unit is returned to the feed tank, via ports in the Relay Valve, ready for the next charging of the accumulator.

The engine can be inched over for making adjustments or checking freedom, with the accumulator discharged, by holding the Relay Valve open and operating the Hand Pump.

A single Accumulator contains sufficient oil for one starting impulse when used with the B50 Starter Unit, and three impulses with the smaller B35 Starter Unit, before oil recharging by operating the Hand Pump.

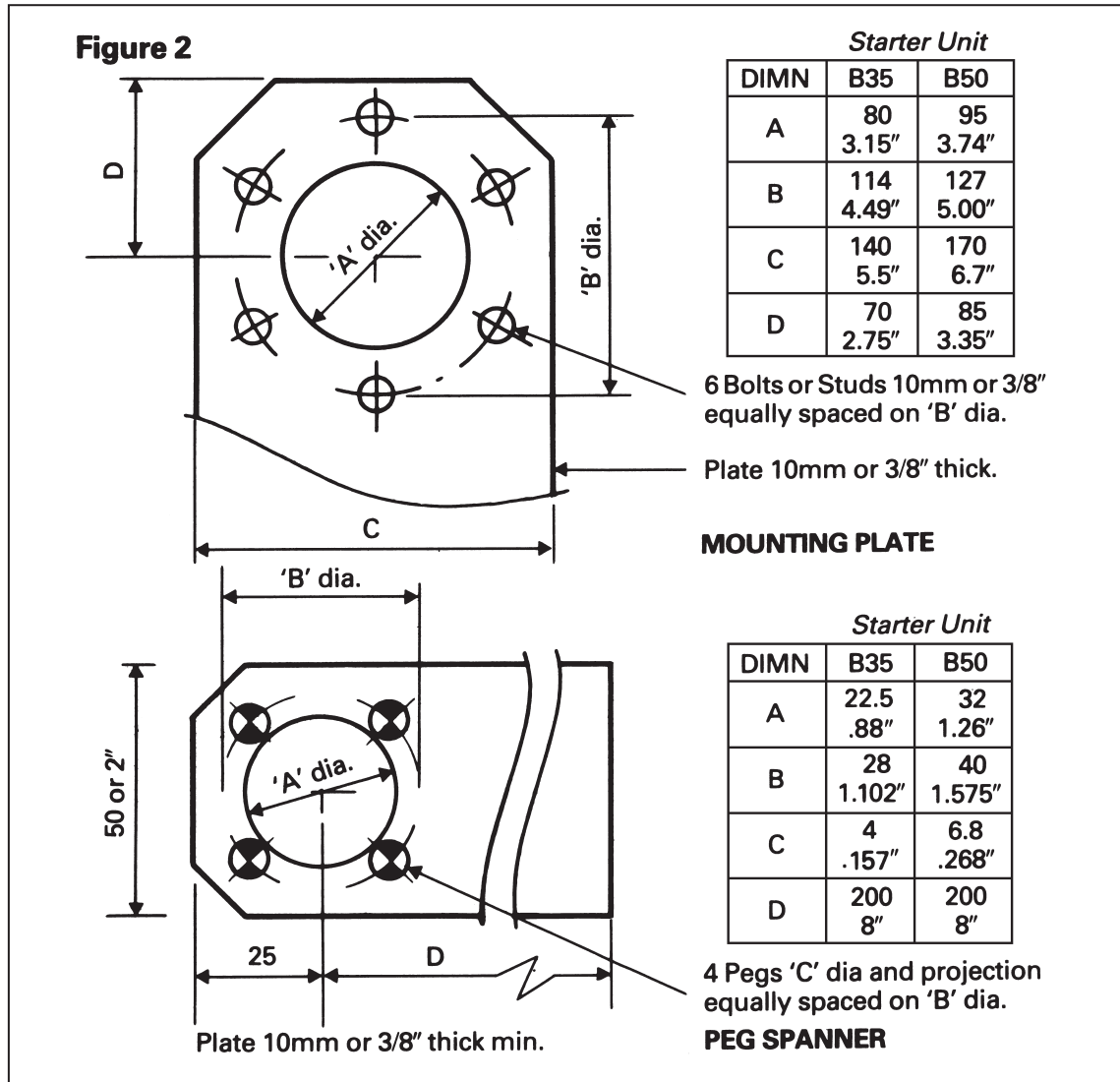

## **SERVICING THE HANDRAULIC STARTER**

The numerical references used in the text to identify components correspond to item numbers used in the Spare Parts Lists.

Before dismantling any equipment, or carrying out any servicing, it is essential for the workbench, tools and component trays to be scrupulously clean.

Only clean diesel oil should be used for washing purposes. We do not recommend using paraffin (kerosene) as it can contain water, which may cause corrosion.

Particles of dirt or any foreign matter in the starter system will lead to premature failure, by causing valves to leak, damaging seals, or obstructing small orifices in the Relay Valve.

Seals and washers should be renewed if there is any doubt of their suitability for further service, and copper washers annealed before use.

### **STARTER UNITS B35G8 AND B50G53**

The following instructions apply to both of the above units except where stated. Refer to page 17 for illustration.

Detail difference between B35G8 and B50G53

On B35G8, rack travel is arrested by a mitred shoulder abutting a circlip fitted to a groove machined in the cylinder.

On B50G53, rack travel is arrested by a flat shoulder abutting a stop washer (20) clamped between cylinder and housing.

Do not operate the starter unit unless it is secured to the mounting on the engine.

During operation the starter pinion is fed forward and rotated at high speed and engagement teeth can inflict severe injury. To assist dismantling and assembly a firmly fixed mounting plate, and peg spanners as shown in fig 2 are necessary in addition to normal workshop tools.

### **Dismantling**

Bolt the starter housing to the mounting plate.

Unscrew the front cover (2). Remove the pipe assembly after unscrewing pipe nuts at each end of the starter unit.

Remove the stud coupling (30) and washer (29).

Slacken nuts (12) retaining the end covers

### **IMPORTANT**

Note that these nuts are the sole means of retaining the end covers and holding captive the rack return springs. Each end cover should be held firmly while the nuts are being removed, and the springs allowed to expand slowly against hand pressure until they exert no further force. Note from which side of the centre housing each cover is removed as the dowel and spring plug (7,8) have alternative positions on assembly.

To withdraw the pinion.

If the purpose of dismantling is solely to change the pinion, refer now to re-assembly page 7.

Using a peg spanner Figure 2, remove each cylinder cover (10). It may be necessary to clamp each cylinder to prevent rotation, using a strap wrench or pipe clamp (46mm/1.81" – B35, 64mm/2.52" – B50).

Push out the rack assemblies. Unscrew each cylinder, and remove the stop washers (20). Keep these with their respective racks and cylinders, and note from which position on the centre housing each was removed.

Wash all parts in clean fluid, dry – preferably by air blast, and inspect for damage, wear and corrosion. Remove any burr from the helical grooves of the pinion using an oil stone.

## **Assembly**

### Racks and Cylinders

Inspect the "U" seal and backing ring (17,18) and joint ring (11) and fit replacements if necessary.

The sealing lips of the "U" seal, and its back face must be free from cuts, tears or other discontinuity. Radial marks on the back face indicate the leakage has been occurring past the inner sealing lip.

The PTFE backing ring should be replaced if the thickness is below 1mm for B35 or 2mm for B50.

A small fringe, which may form on the back face, should be cut off carefully flush with face using a sharp knife or razor blade.

When fitting new seals, they and the rack should be greased lightly to prevent the seals being twisted or damaged. See figure 3 for correct assembly. Note that the chamfer in the bore of the backing ring must face away from the "U" seal.

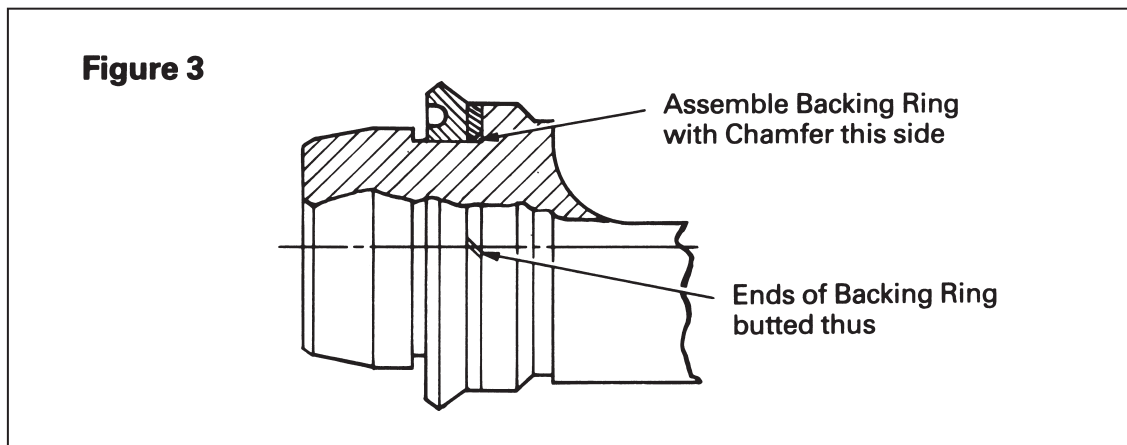

Refit rack stop washers in their original position unless they are damaged or faulty, in which case use new washers of the same thickness.

Renew cylinders if bores are scored, rough or rusty.

Screw and tighten the cylinders into the centre housing, ensuring that each is fully home and clamping the stop washer against the housing. Smear the rack assemblies and cylinder bores with grease. Slide the rack into the cylinder taking care not to damage the backing ring or sealing lip of the “U” seal as they enter the honed bore and push each fully home.

Put the pinion in position, and push the racks inwards simultaneously. With pressure maintained, check that the pinion is free to slide, and that there is a small amount of backlash between pinion and rack teeth.

If the Pinion is not free, reverse the position of the racks.

Retract adjusting screw (14) so that the underside of the head is flush with the cover face (10) but without distorting spring (15).

Using a new joint ring (11) replace the cylinder cover (10) and tighten firmly.

Remove the pinion, and push the racks outwards to the full extent of travel.

Grease the pinion, slide it into mesh with the racks, and push it fully into the housing. Check that each of the helical grooves cut in the periphery is visible in the larger of the two holes (for the spring cups) on each side of the centre housing.

Put the steel balls in the spring cups, springs, spring guides and rack return springs (2 each side on B35, 3 on B50).

Re-fit the end covers, making sure that each is assembled to the correct side of the centre housing. The two holes each side for the locating dowel and spring cup are reversed in position, and the spring plug and dowel assembly position in the end cover is varied to suit.

Check and adjust if necessary the axial position of the pinion, to a dimension of 2.5mm +/-0.2mm from the starter mounting flange to the tops of the teeth.

The adjustment is by rack adjusting screws fitted in the cylinder cover.

Adjust the screws by equal amounts, ensure that the pinion is still free. Clockwise rotation of the screws causes the pinion to advance.

Refit the stud couplings, and pipe assembly.

**HAND PUMP 6518-13** Refer to page 18.

## **SERVICING**

Three spare part kits are available for the pump as shown on page 19.

1. Seal Kit                6518-27
2. Gauge Kit            6518-28
3. Linkage kit           6518-29

## **DISMANTLING TO REPLACE SEALS**

Note: Make sure the tank is fully drained and then grip the pump tank securely in a vice before trying to dismantle. Remove the gauge and linkage assembly first to reduce the possibility of damage to these items. It is recommended that only seal replacement be carried out on the pump. Other pump faults are serviced by replacement.

### **Gauge Assembly**

Remove the gauge assembly using a 19mm spanner. The gauge requires little maintenance except checking for any leaks, and if the gauge is faulty it is serviced by replacement with service kit 6518-28.

### **Linkage**

Remove the circlips and withdraw the 2 pins and levers from the lever support housing. Pay particular attention to wear of the pins (1) levers (28) and lever support (12). Replace any parts, which are worn, damaged or otherwise unsuitable for re-use with service kit 6518-29.

### **Release Valve**

This is located on the left-hand side of the pump. Undo the locknut (2) and release the grub screw (7) slightly before removing the main valve body (4) and washer (5). Remove the pinion (6) and ball (3). If the release valve is leaking past the adjusting screw it will be necessary to replace the seal (38).

### **Main Pumping Piston**

Remove the main piston by inserting a suitable bar in the hole on the end of the piston then slowly turning and pulling the piston assembly, withdraw the main piston from the pump body. If required the top (36) and bottom (37) seals can be removed using a pointed scriber to prise them from their recesses.

### **Filter**

Undo the filter plug located at the back, on the right hand side of the pump. Then using pointed pliers pull out the filter mesh (8) from its seating. Clean the filter mesh.

### **Relief valve**

The relief valve is on the right-hand side of the pump. Remove the main body (4), washer (5) and steel ball (40). **Do not undo the locknut (2) and alter the adjusting screw setting (41)**. If the relief valve is leaking past the adjusting screw (41) it will be necessary to replace seal (38). Remove the spring assembly (39,42,43) from the body to get to the seal (38) for replacement.

## **CLEANING**

Clean pump body and internal parts after dismantling using a fluid for use with viton seals i.e. clean diesel oil. Blow out all galleries and ports before re-assembly. Replacement of any damaged or worn seals is by Hand pump service kit 6518-27.

## **ASSEMBLY**

Assembly is a reverse of the dismantling procedure noting the following:

### **Release Valve**

Place the steel ball (3) in the port then screw in the release valve body assembly (4,6,38) remembering the copper washer (5). Tighten the grub screw (7) using a 5mm hexagonal wrench. (**Do not over tighten**). Lock the grub screw in position with the lock nut (2).

### **Relief valve**

Place the steel ball (40) in the port then screw in the release valve body assembly (4,38,39,42,43) remembering the copper washer (7).

Note: If the relief valve seal (38) has been changed or there is doubt about the relief valve pressure setting, this must be checked when unit is finish assembled. The relief valve is set at 5000 lbf/in<sup>2</sup> and is adjusted by releasing the locknut and turning the grub screw (41) using a 5mm hexagonal wrench clockwise to increase pressure and anti-clockwise to decrease pressure.

### **Main Pumping Piston (6)**

Replace the main piston carefully pushing and turning into the pump body. Do not hit the end of the piston.

### **Linkage**

Connect the lever support (12) to the piston with pin (1) and circlips (13). Do not over stretch the circlip when fitting. Place the 2 connecting levers (28) into the lever support (12) and fit the second pin and circlip. Connect the levers to the bracket using the bolt and nut (29,30). Carefully tighten making sure the levers are free to move in the bracket.

### **Gauge Assembly**

Reconnect the gauge assembly, ensuring it does not foul on the tank return pipe.

**RELAY VALVE RV7:** Refer to page 20

Note. Before disconnecting or attempting to remove the Relay Valve, release the system pressure by operating the Relay Valve lever, then drain the feed tank by disconnecting the 12mm pipe to the starter and pumping the Hand Pump, collect the fluid in a clean container for re-use.

**ACCUMULATOR:** Refer to page 21

Note. Before disconnecting or attempting to remove the Accumulator, release the system pressure by operating the Relay Valve lever, then drain the feed tank by disconnecting the 12mm pipe to the starter and pumping the Hand Pump, collect the fluid in a clean container for re-use.

**FILLING AND VENTING THE SYSTEM**

After mounting and connecting the various units, fill the Feed Tank with approved hydraulic fluid to the indicated level.

Pull the Relay Valve operating lever to the fully open position and operate the hand pump gently until the starter racks have engaged the pinion and then completed their travel – about  $\frac{3}{4}$  turns of the engine crankshaft.

Release the Relay Valve lever, thus allowing the fluid to be returned to the feed tank by the spring loaded starter racks.

Allow air to vent from the returning fluid, repeat as necessary until returning fluid is free from air. Check the feed tank level and top up as necessary.

If the hand pump fails to deliver fluid, it will be necessary to vent it by slackening the gauge union a couple of turns and operating the lever until fluid emerges free from air bubbles. Retighten the union and resume venting.

**Do not attempt to vent the system by removing or disturbing the relief valve.**

The system is self-venting in service if laid out as we recommend, and further venting should only be necessary if pipe runs have been disconnected, or the starter set is operated with insufficient fluid.

If the starter fails to engage properly or disengages during operation, this may be due to air in the system, and it should be vented as described.

When checking the fluid level in the Feed Tank make sure first that there is no pressure in the system, by operating the relay lever valve.

## PIPE CONNECTIONS

Use only the correct size and specification of seamless, ductile, high-pressure quality of steel pipe, and the correct fittings as supplied by Prestolite.

Three sizes of pipe are used in the starter system.

**6mm diameter:** Connecting the hand pump to the relay valve and accumulator assembly.

**10mm diameter:** Connecting feed tank and relay valve, and two high pressure pipes on starter unit. Minimum inside radius of bend 38mm (1½").

**12mm diameter:** Connecting relay valve to starter unit. Minimum inside radius of bend 51mm (2").

### IMPORTANT:

Always make sure that metal filings, burrs and dirt are removed from pipes and unions before fitting to the system, especially when new pipes have been made, or existing pipes modified.

Cut the pipe to the correct length and square to its axis. Remove burrs by lightly filing, without chamfering the outside diameter. Roll cutters are not advised, as they tend to close the end of the pipe, cause heavy burrs and may damage the sealing diameter.

Clean and oil or grease all surfaces of the pipe, union body, nut, collet "O" ring etc.

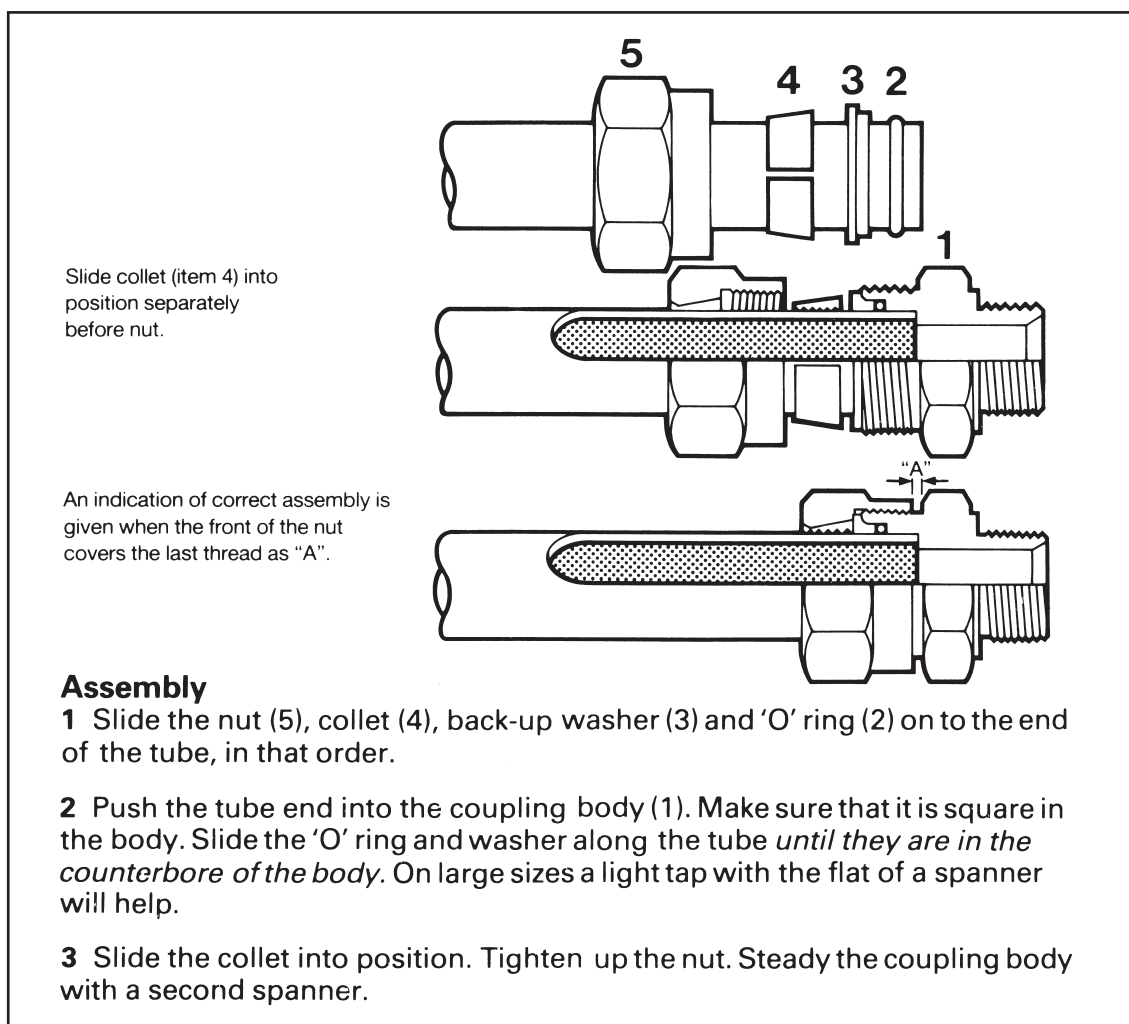

## ROUTINE MAINTENANCE

### Weekly

Operate Starter. Inspect for oil leaks at all unions. Where leaks are apparent check whether they are from the pipe "O" ring or coupling washer.

### Refer to page 2. Safety Precautions

Leak from pipe "O" ring.

Leak from coupling washer. Slacken union nut while holding the coupling body, tighten coupling body, and retighten union nut.

If leakage still occurs, replace the coupling washer.

### Monthly

Check fluid level in feed tank, and add fluid if necessary.

Grease the relay valve lever pivot.

Check all mounting nuts and bolts, especially those fixing the starter unit, and tighten as necessary. Renew any broken or missing spring washers.

## Quarterly

Remove starter unit front cover, and check free movement of racks. Hold relay valve lever at fully open position and operate the hand pump. The starter pinion should move slowly into engagement with the engine dog, then rotate about three quarters of a turn.

After releasing the relay valve lever the pinion should rotate freely and return to its original position. On completion of its return, a distinct click should be heard as the spring loaded location balls re-engage with the helical slots of the pinion. Failure of the racks to return may be due to accumulation of hard grease or dirt in the centre housing or on the rack and pinion teeth. Strip, clean, and adjust as described in the SERVICING INSTRUCTIONS. Page 5.

Remove feed tank air breather, wash in clean fuel oil and refit.

In very dusty conditions the feed tank air breather may require cleaning more frequently.

## TROUBLE SHOOTING CHART

Fault	Possibly Cause	Suggested Check & Remedy
1. Starter operates but does not turn engine.	1. Worn or broken teeth on engine dog or pinion.	Remove starter unit check engine dog and pinion, and replace as necessary.
	2. Pinion advance mechanism worn or jammed due to dirt, burrs or broken springs.	Remove starter unit, strip end covers, spring-loaded balls and pinion. Examine, clean, deburr helical grooves or fit new parts as necessary.
	3. Air locks in fluid system	Vent starter system.
	4. Use of wrong fluid of too high viscosity.	Drain system, refill with correct fluid and vent.
	5. Starter misaligned.	Remove starter unit and check alignment position of mounting bracket.
	6. Relay valve plunger worn allowing fluid to leak to feed tank when relay valve is operated.	To check, remove air breather. Operate hand pump, oil should not return to feed tank until relay valve lever has been released. Replace relay valve.

## TROUBLE SHOOTING CHART

Fault	Possibly Cause	Suggested Check & Remedy
2. Starter does not operate.	<ol style="list-style-type: none"> <li>1. Insufficient fluid pressure. Lack of fluid.</li> <li>2. Loss of residual gas pressure from accumulator.</li> <li>3. Rack seals in starter unit leaking.</li> <li>4. Relay valve plunger worn.</li> </ol>	<p>Operate hand pump to increase pressure. Check and top up level.</p> <p>Operate relay valve to discharge oil pressure completely.</p> <p>Operate hand pump. Pressure gauge should register about 200 bar (2900 lbf/in<sup>2</sup>) for standard accumulator, after 3 or 4 strokes of the hand pump with fluid system vented correctly.</p> <p>Replace accumulator.</p> <p>Indicated by sudden leakage from starter unit. Replace seals.</p> <p>Proceed for fault 1.6.</p>
3. Starter operates but racks do not return.	<ol style="list-style-type: none"> <li>1. Broken rack return springs.</li> <li>2. Incorrect adjustment of racks.</li> <li>3. Relay valve plunger stuck.</li> <li>4. Pinion stuck.</li> </ol>	<p>Possible if springs are badly corroded. Fit new “greased” springs.</p> <p>Adjust as described in servicing instructions.</p> <p>Replace relay valve.</p> <p>Proceed as for fault 1.2.</p>
4. Inability to pressure system.	<ol style="list-style-type: none"> <li>1. Hand pump not vented.</li> <li>2. Lack of fluid.</li> <li>3. Insufficient flow of fluid to hand pump.</li> </ol>	<p>Lever will lack resistance during pumping. Vent as described under “filling and venting system”.</p> <p>Check feed tank fluid level. Top up as necessary. Check system for leaks.</p> <p>Clogged filter. Remove filter and clean as described in servicing instructions.</p>



## TROUBLE SHOOTING CHART

Fault	Possibly Cause	Suggested Check & Remedy
6. Loss of pressure after charging system.	<ol style="list-style-type: none"> <li>1. Leak from hand pump check valve, or relay valve assembly</li> <li>2. Leak from unions, pipes</li> <li>3. Accumulator losing gas charge to atmosphere.</li> </ol>	<p>Remove check valves, clean and replace.</p> <p>Replace relay valve.</p> <p>Examine system for external leaks and cure as appropriate.</p> <p>Proceed as for fault 2.2. After checking accuracy of pressure gauge. Replace accumulator.</p>
7. Oil blows out of hand pump tank breather after releasing relay valve.	<ol style="list-style-type: none"> <li>1. To much fluid in tank.</li> <li>2. Accumulator losing gas charge to fluid system.</li> </ol>	<p>Check fluid level. Should be 50mm from the top of the tank.</p> <p>If fault persists after venting, replace accumulator.</p>
8. Fluid leaking from main piston.	<ol style="list-style-type: none"> <li>1. Damaged large main piston seal (36).</li> </ol>	<p>Replace Seal</p>

**STARTER UNITS B35G8 AND B50G53 ARE SERVICED  
BY KITS 47920235 OR 47920253**

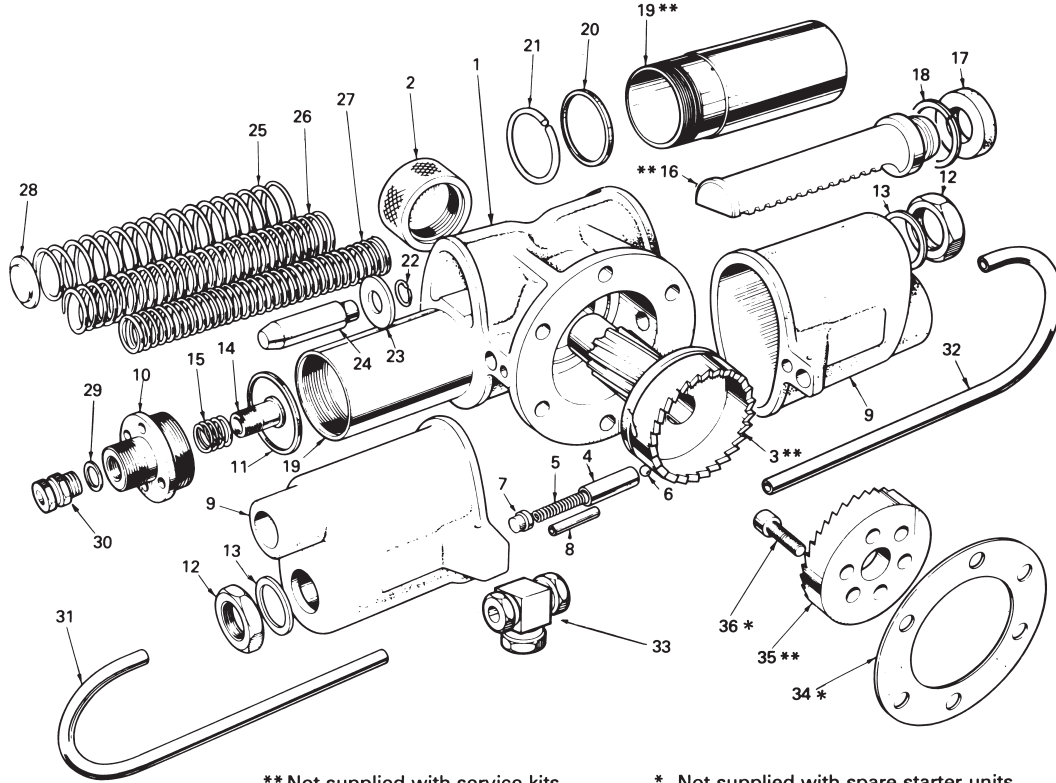

\*\* Not supplied with service kits, available as individual items.

\* Not supplied with spare starter units or service kits, order separately.

Item	Kit Contents	B35G8	B50G53
1	Not Available		
2	Not Available		
3	Pinion **	527/6	526/599
4	Spring Cup	47920235	47920253
5	Spring	47920235	47920253
6	Steel Ball	47920235	47920253
7	Spring Plug	47920235	47920253
8	Grovelock Pin	47920235	47920253
9	Not Available		
10	Cylinder Cover	47920235	47920253
11	Joint Washer	47920235	47920253
12	Cover Nut	47920235	47920253
13	Washer	----	47920253
14	Adjusting Screw	47920235	47920253
15	Spring	47920235	47920253
16	Rack **	527/124	526/718
17	“U” Seal	47920235	47920253
18	Backing Ring	47920235	47920253
19	Cylinder **	527/28	526/130
20	Stop Washer 2.4	47920235	----
	Stop Washer 3.8	----	47920253
21	Circlip	47920235	----

Item	Kit Contents	B35G8	B50G53
22	Circlip	47920235	47920253
23	Retaining Washer	47920235	47920253
24	Spring Guide	47920235	47920253
25	Spring Outer	47920235	47920253
26	Spring Middle	----	47920253
27	Spring Inner	47920235	47920253
28	Retaining Plate	47920235	47920253
29	Washer	47920235	47920253
30	Coupling * (1)	47920235	47920253
31	Pipe Small Bend	47920235	47920253
32	Pipe Large Bend	47920235	47920253
33	Tee Piece * (1)	47920235	47920253
34	Shim 0.4 **	527/57	526/233
35	Engine Dog **	527/4	526/148
36	Capscrew **		
	3/8 BSF	311/608	311/608
36	Capscrew **		
	3/8 UNF	313/608	313/608
36	Capscrew **		
	M10	381/1025	381/1025
ND	Pipe S29 Long	527/134	----
ND	Pipe S29 Short	527/133	----

(1). For assembly instructions see page 5

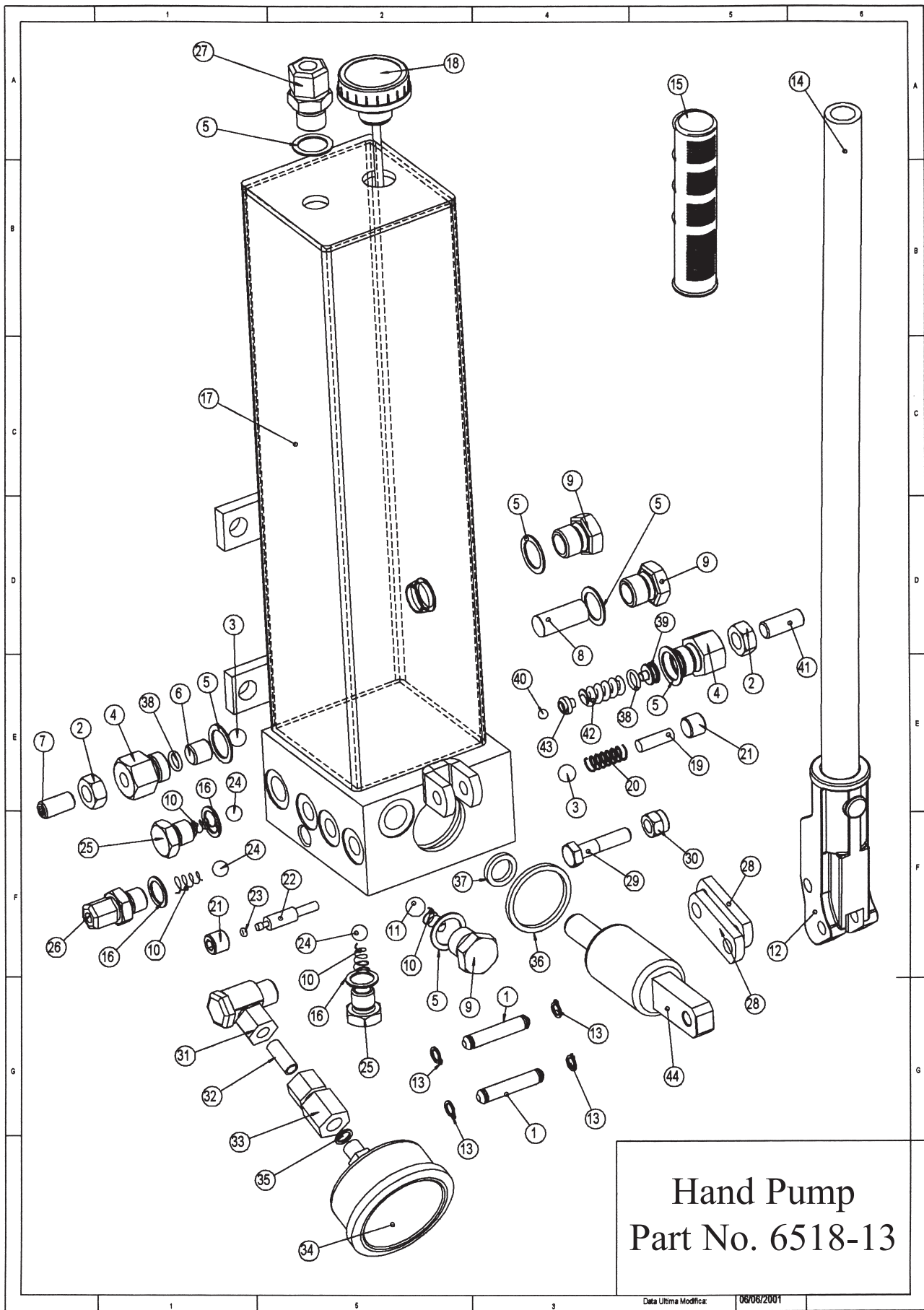

Hand Pump  
Part No. 6518-13

Data Ultima Modifica: 06/06/2001

Pos.	Pcs.	Description
31	1	Swivel fitting
32	1	Extension
33	1	Fitting
34	1	Pressure gauge 0-400 Bar
35	1	Washer

Service Kits  
"GAUGE" 6518-28

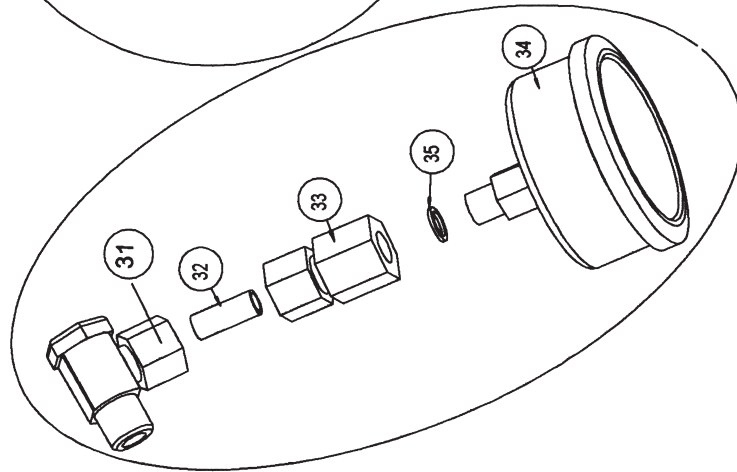

Pos.	Pcs.	Description
23	1	Seal
35	1	Seal
37	1	Seal
38	2	Seal

Service Kits  
"SEALS" 6518-27

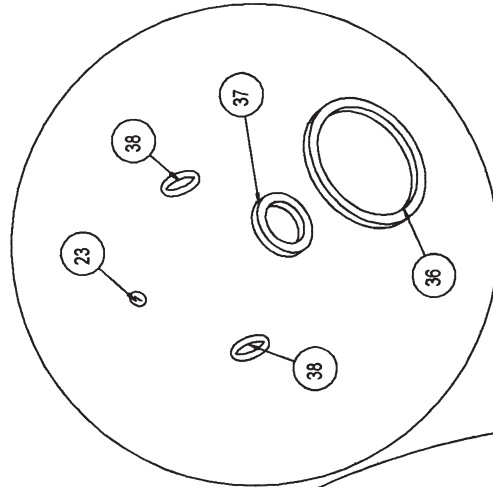

Pos.	Pcs.	Description
1	2	Pin
12	1	Lever support
13	4	Circlip
28	2	Leverism
29	1	Screw
30	1	Selflocking nut

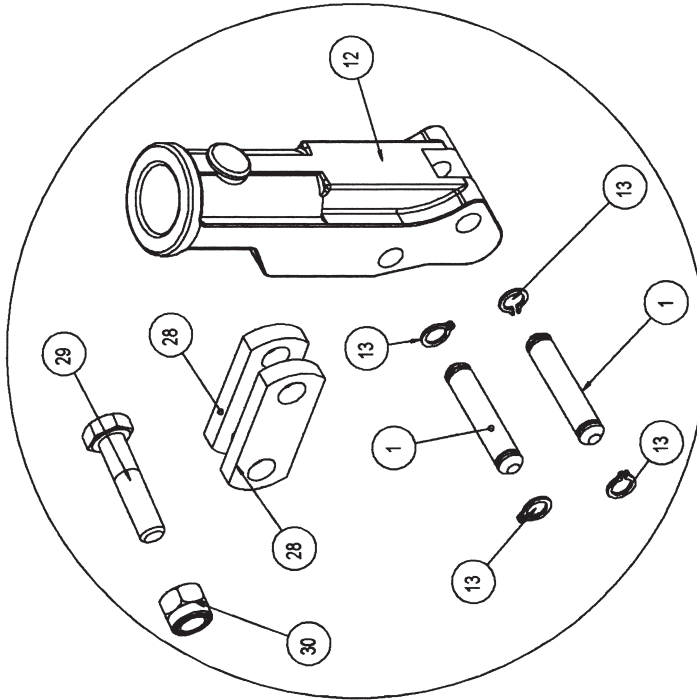

Service Kits "LEVER" 6518-29

## Service Kits for 6518-13

9-7-01

**RELAY VALVE RV7 - IS SERVICED BY REPLACEMENT**

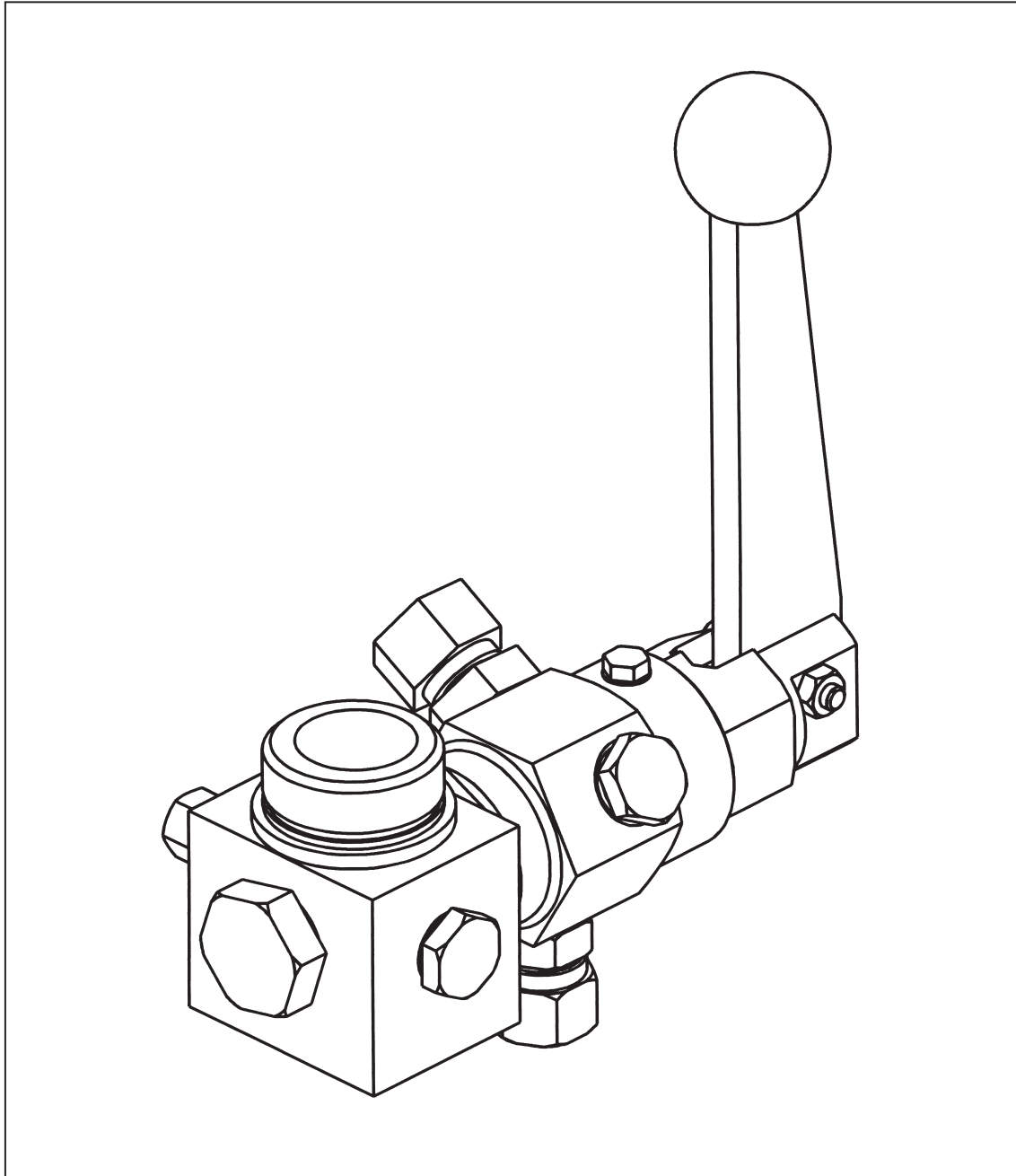

**STANDARD ACCUMULATOR – IS SERVICED BY REPLACEMENT**

**Part Number: 6518-24**

Residual Pressure  
200 bar  
(2900 lb/in<sup>2</sup>)

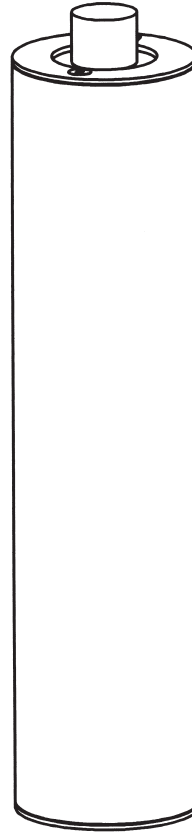

Sealing Washer 113/45 fitted between  
Accumulator and Relay Valve  
Supplied with each Accumulator



**WARNING**

Do not attempt to dismantle nor flame cut the accumulator. It is permanently charged with an inert gas at high pressure, and is service by replacement.

**UNAUTHORISED DISMANTLING CAN HAVE FATAL RESULTS**

When accumulators are being disposed of, it is important to release the residual gas charge from the unit beforehand using a standard charging kit.

**PIPES FOR PANEL MOUNTED ANCILLARIES  
SINGLE ACCUMULATOR SETS**

Pipes 1 & 2 are supplied  
In service kit 6518-26

1. Hand Pump To Relay Valve  
6mm Diameter - 6518-4
2. Relay Valve to Feed Tank  
10mm Diameter - 6518-3

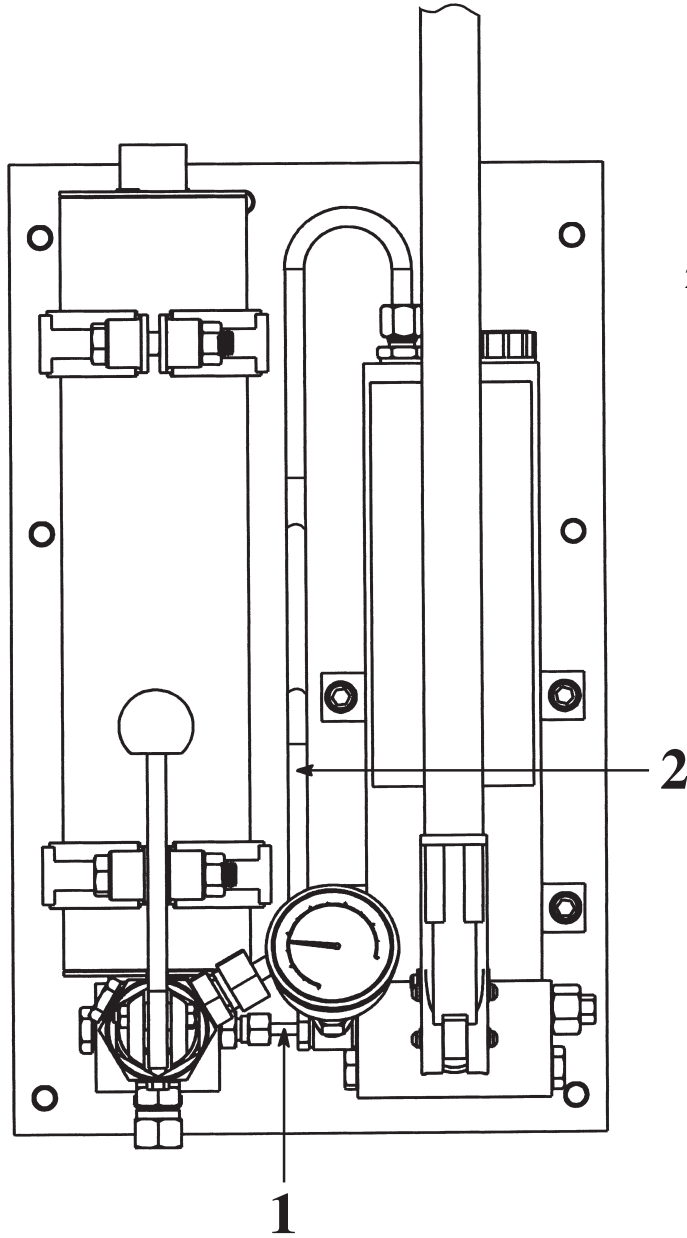

Service Notes

Service Notes

Service Notes

## The following engines have been fitted with Prestolite Handraulic Starters

Suitable for applications such as compressors, generators, cranes, rail traction, marine and pumping sets. Used extensively by Oil Companies, Military and Government Departments, Ship and Lifeboat Builders, Contractors and Plant Manufacturers.

Engine	Type	Starter	Engine	Type	Starter	Engine	Type	Starter
Bernard	W 34	B35G	Fiat	8061M	B35G	Mitsubishi	3F-5S	B35G
Caterpillar	334	B50G		8035	B35G		3G-2S	B50G
	342	B50G		CO3	B50G		S 12 N	B50G
	343	B50G	Foden	FD	B35G		6D20 PTK	B50G
	346	B50G					6D14T	B50G
	353	B50G	Ford	2400E	B35G	MTU	V183	B50G
	3208	B50G		2500E	B35G			
	3304	B50G		2710E	B35G	M.W.M.	226	B35G
	3306	B50G		2800E	B50G		232	B50G
	3406	B50G	Gardner	LW	B50G		302	B35G
	3412	B50G	International	UD 282	B35G		327	B35G
Cummins	V 378	B35G	Isuzu	C 221	B35G		916	B35G
	V 504	B50G					917	B35G
	NT 855	B50G	Kubota	KD 22	B50G	Perkins	4/108	B35G
	B Series	B35G		MKE	B50G		3/152	B35G
	C Series	B50G	Leyland	400	B35G		4/203	B35G
Detroit Diesel (General Motors)	220	B35G	(BL)	680	B50G		4/236	B35G
	330	B35G					6/354	B35G
	381	B50G	Lister	2/3 HA	B35G		V8 510	B50G
	466	B50G		2/3 HR	B35G		V8 540	B50G
	500	B50G		4/6 HA	B50G	Petter	PD	B50G
	53 Series	B35G		4/6 HR	B50G		PH	B35G
	71 Series	B50G		JA	B50G		PJ	B35G
				JW	B50G		AVA	B35G
Deutz (K-H-D)	F-L 413	B50G		JP	B50G			
	F-L 514	B50G	Man	D 2542	B50G	Rolls-Royce	C	B50G
	F-L 714	B50G		D 2565	B50G		SF	B50G
	FM 716	B50G		D 2566	B50G	Ruggerini	RD 901	B35G
	F-L 812	B35G		D 2800	B50G			
	BA-M 816	B50G		D 0226	B35G	Scania	DS 8	B50G
	F-L 912	B35G					DS 11	B50G
	F6L 913	B35G	Mercedes	OM 314	B35G		DS 14	B50G
Dorman	LB	B50G		OM 352	B35G	Volvo	MD 32	B35G
	LD	B50G		OM 355	B50G		MD 70	B50G
	LE	B50G		OM 360	B50G		MD 100	B50G
	4/6 DA	B35G		OM 401	B50G		MD 120	B50G
	8 DA	B50G		OM 402	B50G			
	Y DA	B50G		OM 403	B50G	Yanmar	5 KDAL	B50G
	8 J	B50G		OM 404	B50G			
	6 Q	B50G						

Many other engines can be equipped with PRESTOLITE Handraulic Starters and reference should be made to PRESTOLITE Starter Sales for guidance on the method of installation.

Prestolite Electric Ltd - Heavy Duty Systems Larden Road Acton London W3 7RP  
Telephone: 020 8735 4500 Fax: 020 8743 6508