

**Indian Maritime University**  
**(A Central University, Govt of India)**

**Supplementary Examinations – September/October 2024**

**Programme Name: B Tech (ME)**

**Semester: II**

**Subject Code: UG11T4202**

**Subject Name: Basic Electrical Engineering**

---

Date: 14.09.2024

Max Marks: 70

Duration: 03 Hrs

Pass Marks: 35

---

General Instructions

- (i) All Sections (A, B & C) are to be attempted.
- (ii) Options, if any, are specified in respective section.

**Section A**

Ten MCQs/Fill in the Blanks of 01 Mark each – Choose the correct answer as applicable.

1. \_\_\_\_\_ is used to describe the current.
  - a. Coulomb
  - b. Coulomb/sec
  - c. A/m
  - d. Joules/coulomb
2. The opposition offered by a material to the flow of current in a DC circuit is
  - a. Resistance
  - b. Reactance
  - c. Admittance
  - d. Impedance
3. Which of the following materials does not obey ohm's law?
  - a. Copper
  - b. Silver
  - c. Platinum
  - d. Gallium arsenide
4. An electric heater of rating 1000 W is used for 2 hours per day for 20 days. What is the electrical energy utilized?
  - a. 20 kWh
  - b. 2 kWh
  - c. 60 kWh
  - d. 40 kWh
5. The equation of an alternating voltage is given by  $v = 200 \sin 314 t$ . The peak value of the voltage is \_\_\_\_\_ Volts.
  - a. 200
  - b. 141.42
  - c. 180.18
  - d. 222
6. The power-factor of a pure capacitive circuit will be \_\_\_\_\_.
  - a. unity
  - b. zero leading
  - c. zero lagging
  - d. 0.866 lagging
7. Digital multimeter is used for measurement of \_\_\_\_\_.

- a. AC and DC Voltage
  - b. AC and DC Current
  - c. Resistance and continuity
  - d. All of these
8. Tesla is the unit of measurement of \_\_\_\_\_.
- a. Magnetic flux density
  - b. Permeance
  - c. Reluctance
  - d. magnetic flux
9. Form Factor is the ratio of
- a. Average value to r.m.s. value
  - b. Average value to peak value
  - c. r.m.s. value to average value
  - d. r.m.s. value to peak value
10. In Fleming's Right hand rule, the direction of induced e.m.f. is denoted by
- a. thumb
  - b. fore finger
  - c. middle finger
  - d. little finger

### Section B

Five Questions of 02 Marks each

- 11. Distinguish between a Loop & Mesh of a circuit.
- 12. Three resistors  $2\ \Omega$ ,  $4\ \Omega$ , and  $6\ \Omega$  are connected in series. If the applied voltage across this combination is  $36\text{ V}$ , find the voltage drop across each resistor.
- 13. Define the term "Mutual Inductance" between two coils.
- 14. Sketch neatly B - H curve for a coil.
- 15. Determine the energy stored in an inductor of inductance  $100\text{mH}$  when a current of  $0.2\text{A}$  is passed through it.

### Section C

Seven Questions of 10 Marks each of which any 05 questions to be answered.

16. What is the voltage across the  $5\ \text{ohm}$  resistor if current source has current of  $\frac{17}{3}\text{ A}$ ? (10 marks)

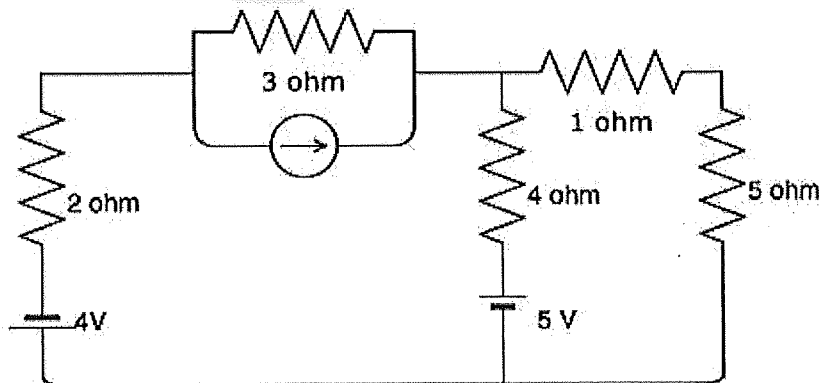

17. Find the value of the currents  $I_1$  and  $I_2$ . (10 Marks)

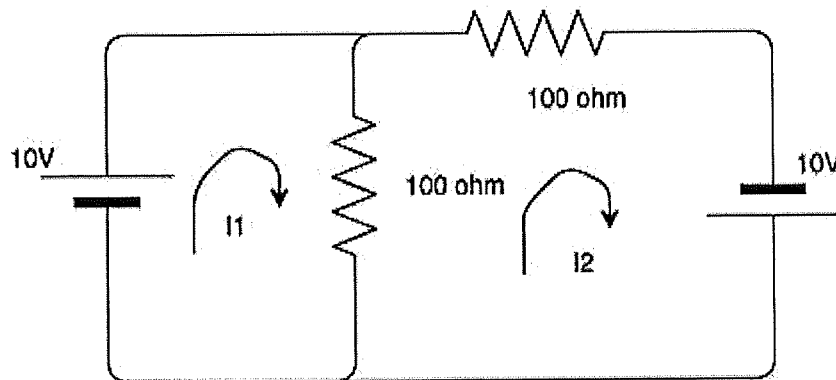

18. The current  $i(t)$  in a pure resistor of  $10 \Omega$  is shown in the figure. Find the power dissipated in the resistor. Also find the peak factor for the given waveform. (10 Marks)

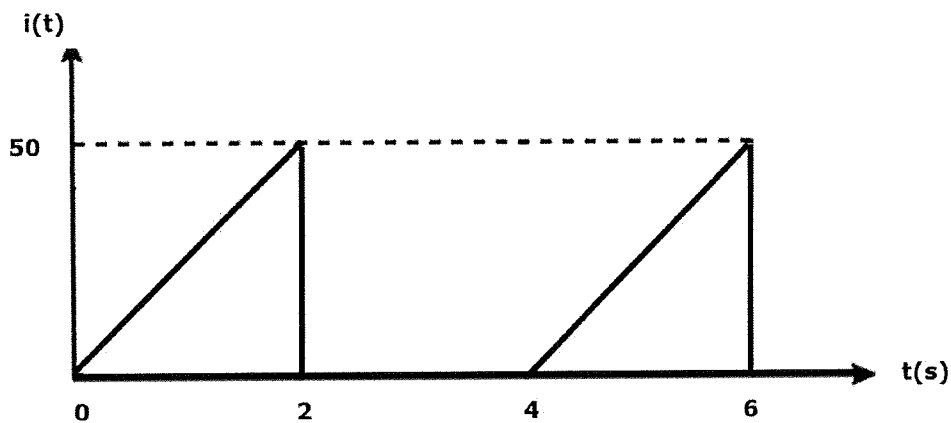

19. (a) The coefficient of induction of a choke coil is  $0.1\text{H}$  and resistance is  $12\Omega$ . If it is connected to an alternating current source of frequency  $60\text{Hz}$  then what will be the value of power factor. (5 Marks)

(b) Explain the characteristics of ideal voltage and current source. (5 Marks)

20. An inductive coil takes  $10\text{ A}$  and dissipates  $1000\text{ W}$ , when connected to a supply at  $250\text{ V}$ ,  $25\text{ Hz}$ . Calculate the impedance, the effective resistance, the reactance, the inductance and the power factor. (10 Marks)

21. (a) Deduce the expression  $e = Blv$ , (where  $B$  is the magnetic flux density in  $\text{Wb/m}^2$ ,  $l$  is the effective length of the conductor in  $\text{m}$ , and  $v$  is the linear velocity in  $\text{m/sec}$ ) when the conductor is moving at right angles to the stationary magnetic field, from basic principles of electromagnetic induction. (6 marks)

(b) State Faraday's law of electromagnetic induction & Lenz's law. (4 marks)

22. Explain the construction and operation of an insulation tester. (10 marks)

