

BOOSTER UNIT AMB-M-50-SS H2390

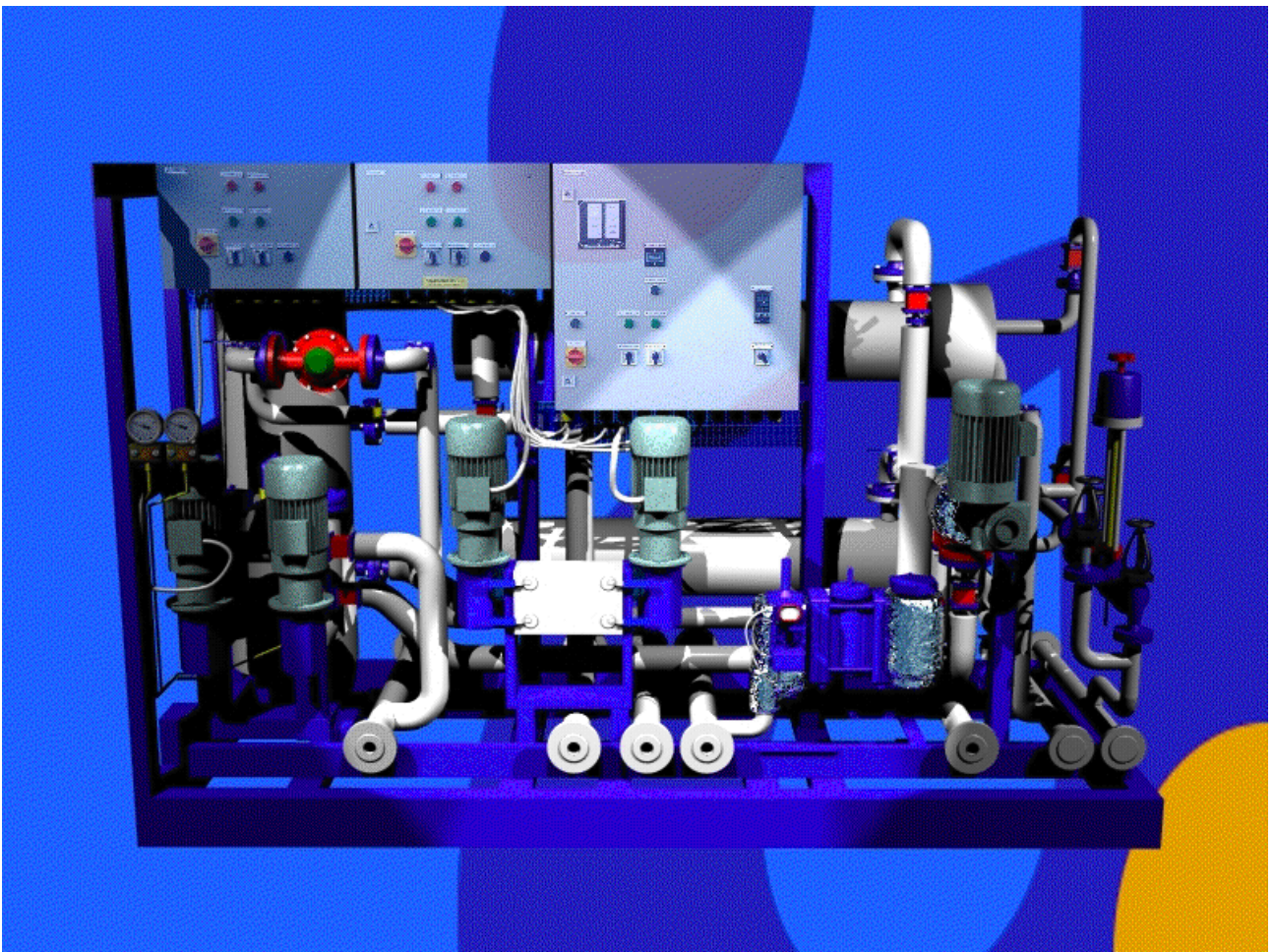

Auramarine serial number 7324

Section	Document id	Revision
1. Data sheet General arrangement	DS7324A 407432	A
2. P&I diagram Part list	306574 PL306574 SPARES 7324B	B
3. Electric drawings Part list	407439A PL407439B	A B
4. Factory certificate	FC7324	
5. Flow meter certificate	47062737	
6. Instruction manual	IM7334A	

INDEX

- 1 Data sheet, general arrangement
- 2 P&I diagram, part list
- 3 Electric drawings, part list
- 4 Factory certificate
- 5 Flow meter certificate
- 6 Instruction manual

SECTION 1

1 Data sheet, General arrangement

Heavy Fuel Oil Feeder Booster Unit

Technical Specification

Type:	Feeder Booster AMB-M-50-SS
Manuf. No.:	7324, 7326, 7328, 7330, 7332, 7334, 7336, 7338, 7867, 7869, 7871, 7873
Manufacturer:	Auramarine Ltd
Site:	Jiangnan Shipyard, 5100 TEU Container vessel Hull No.: H2390~3, H2403~06, H2442~45
Customer:	Hua Hai Equip. & Eng. Co. Ltd

1. Design Basis

Engine type :	MAN 8K98MC MARK6
Total power max.:	45 760 kW
HFO viscosity max.:	600 cSt / 50 °C
Main voltage:	440 V / 60 Hz
Control voltage:	230 VAC
Fuel consumption max.:	8.67 m ³ /h
Viscosity set point min.:	12 cSt
Injection temperature max.:	151 °C
Working / test pressure:	10 / 15 bar
HFO day tank temp.:	85 °C
Pressurized air:	5-10 bar

2. Technical data

Feeder pump capacity	12.9 m ³ /h, 4 bar, 75 cSt
Electric motor	4.6 kW, 3500 r/min
Booster pump capacity	24.0 m ³ /h, 4/10 bar, 25.8 cSt
Electric motor	12.6 kW, 3500 r/min
Preheaters	2*100 % steam heaters of tube type Max. power 355 kW, based on steam temperature / pressure 164°C/7 bar. Steam consumption 650 kg/h.
Certificate	GL+CCS: 7324, 7326 CCS: 7328, 7330, 7332, 7334, 7336, 7338 CCS: 7867, 7869, 7871, 7873

AURAMARINE LTD

Street address:
Kukkosenapaja 1
FIN-20660 LITTOINEN
FINLAND
Internet: www.auramarine.fi

Postal address:
P.O.BOX 849
FIN-20101 TURKU
FINLAND

Tel + 358 204 86 5030
Fax + 358 204 86 5031
Telex 62595 AUMA FI

Reg. office: Lieto
Trade reg. no: 402.012
ALV rek/ VAT reg: FI06846963

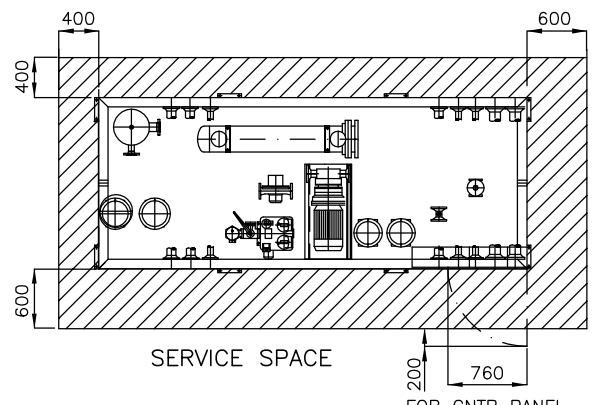
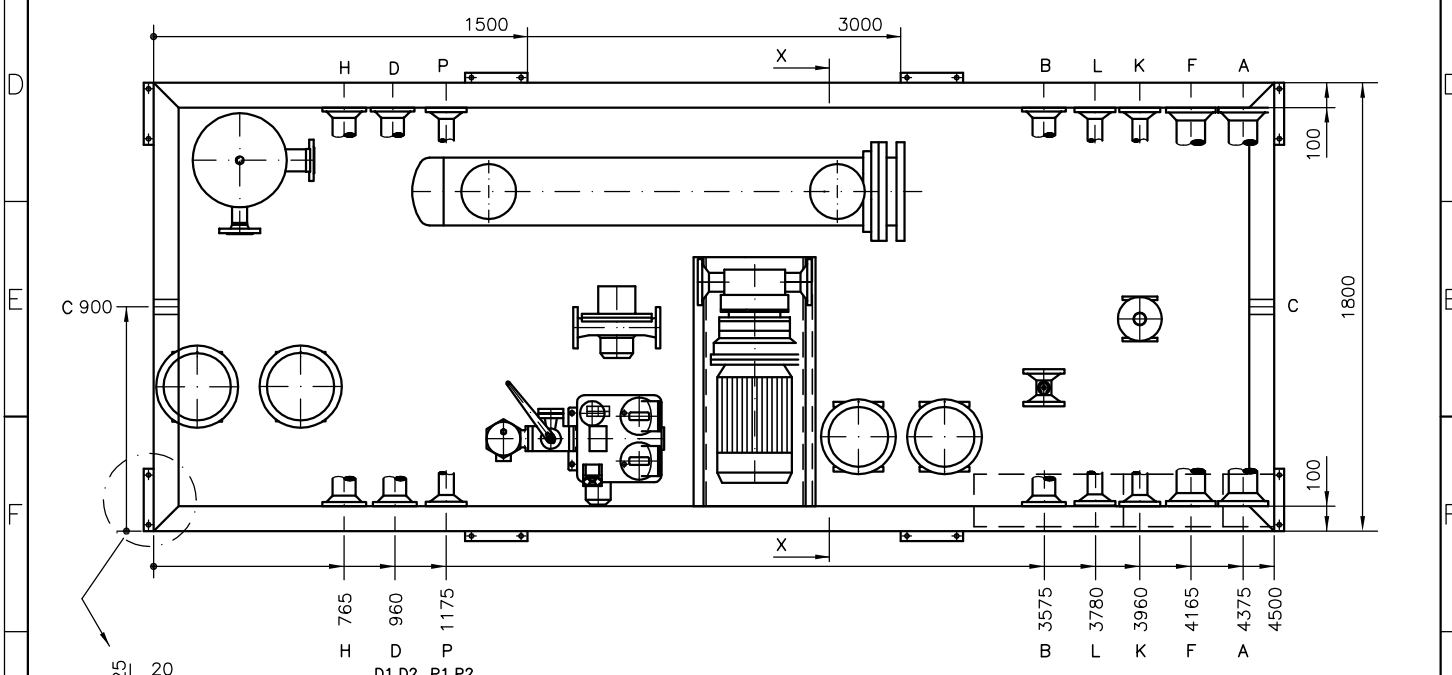
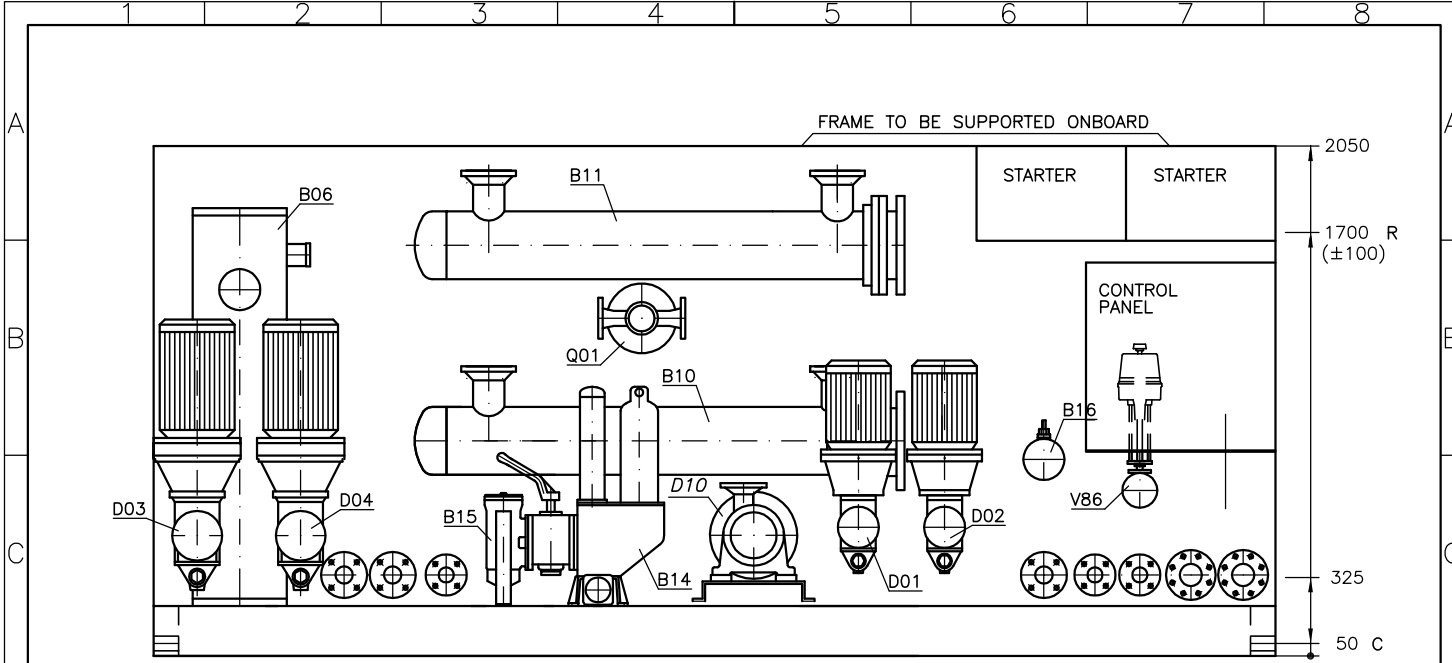

X - X
FASTENING OF THE FRAME BY WELDING ONTO THE FOUNDATION

COUNTER FLANGES ACCORDING TO DIN 2633 PN16
DIMENSION TOLERANCES FOR LOCATION OF PIPE CONNECTIONS ±10 mm

Weight 3200
Manuf. No.: 7324,7326,7328,7330,7332,7334,7336,7338,7867,7869,7871,7873

A	DN80	HFO INLET
B	DN65	FUEL OIL TO ENGINE
C	R2"	DRAIN FROM UNIT
D	DN65	DEAERATION LINE
F	DN80	MDO INLET; OPTIONAL
H	DN65	F.O. RETURN FROM ENGINE
K	DN50	STEAM INLET
L	DN50	CONDENSATE OUTLET
P	DN50	SLUDGE FROM AUTOM. FILTER
R	Ø10mm	INSTRUMENT AIR INLET
D1,D2	Ø10mm	TRACING OF DEAER. LINE
P1,P2	Ø10mm	TRACING OF SLUDGE LINE

 AURA MARINE Auramarine Ltd.		BOOSTER UNIT AMB-M-50-SS JNSY 2390-93, H2403-06 JNSY H2442-45 M/E BOOSTER UNIT GENERAL ARRANGEMENT	
Product	© ACA	UNITS mm,kg	ASLY.DRG
MADE	19.07.2006	TJu/Julin	SCALE
CHKD.	19.07.2006	TPa/Palmu	Page No. DRG. No.
APPD.			~ 1/1 407432

Rev.



SECTION 2

2 P&I Diagram, Part list

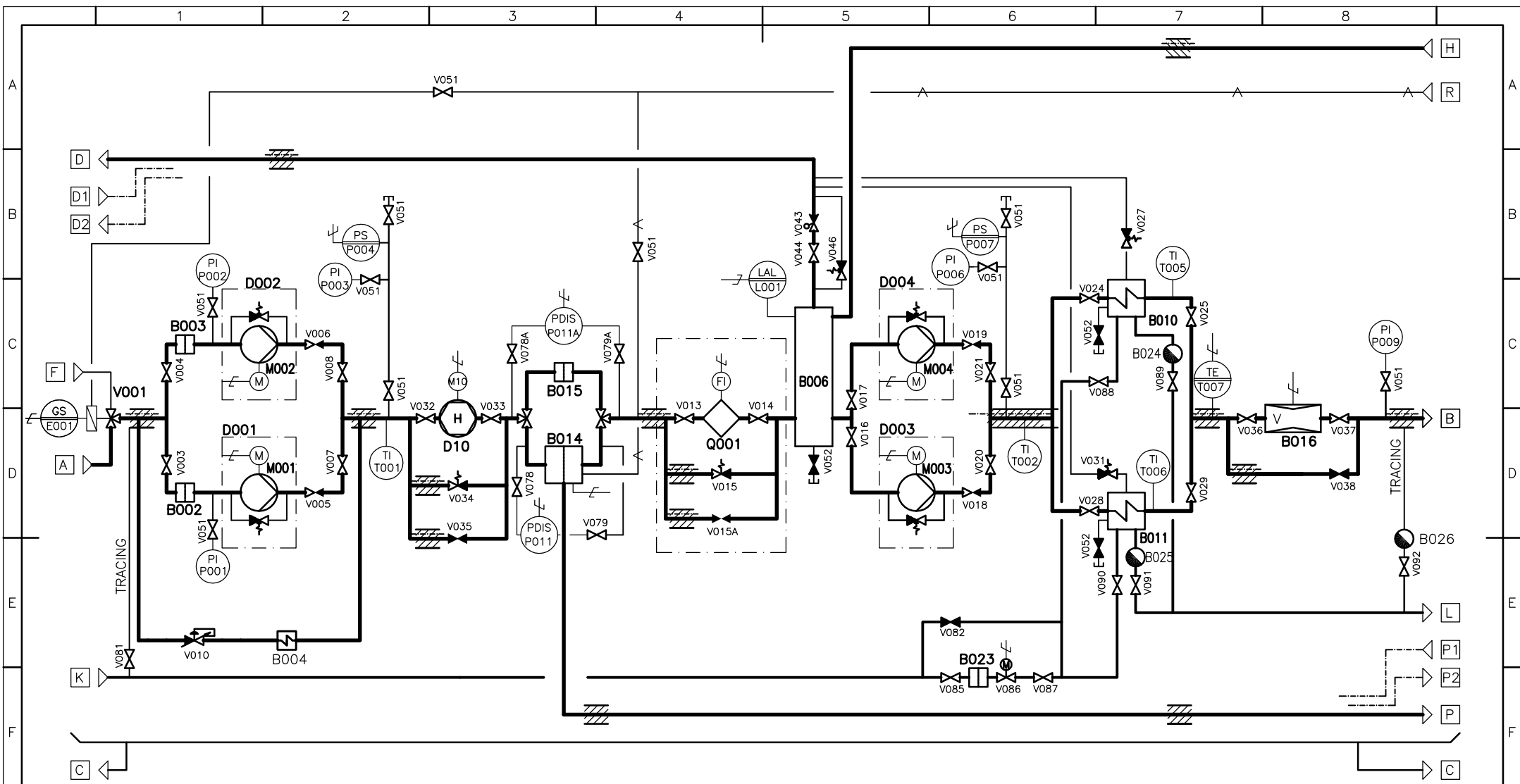

A	HFO INLET
B	FUEL OIL OUTLET
D	DEAERATION/FLUSHING LINE
F	LFO INLET
H	F.O. RETURN FROM ENGINE
P	SLUDGE FROM AUTOM. FILTER
R	INSTRUMENT AIR INLET
K	STEAM INLET
L	CONDENSATE OUTLET
C	DRAIN FROM UNIT

D1,D2 TRACING OF DEAER. LINE
P1,P2 TRACING OF SLUDGE LINE

TRACED AND INSULATED PIPE

REV.	DATE	MADE	APPVD.	EXPLANATION

		BOOSTER UNIT AMB-M-50-SS JNSY H2390-93, H2403-06 JNSY H2442-45 M/E BOOSTER UNIT P&I DIAGRAM	
		Mfg.no. 7324, 7326, 7328, 7330, 7332, 7334, 7336, 7338, 7867, 7869, 7871, 7873	Weight
Made 15.09.2006	TJu/Julin	Asly.Drg	Page
Chkd. 15.09.2006	ISs/Sakkara	© ACA	Scale
Appd.	UNITS	mm kg	~
6	7	8	1/1 306574

Rev.

JNSY H2390-2393, H2403-2406

ITEM	QTY	PART NO	DESCRIPTION	TYPE/TECHNICAL DATA	SET RANGE	SET POINT
B002	1	AM01217	Suction strainer, Basket element	D60, 290/480, PRI-4936-3		
B003	1	AM01217	Suction strainer, Basket element	D60, 290/480, PRI-4936-3		
B004	1	AM00662	Cooler radiator, Rib	For tube 42 mm, 83 r/m 30x1 mm		
B006	1	AM00356	Deaeration vessel	Dwg 6005-3, 200 l		
B010	1	AM03854	Heat exchanger	MX 25,100,L=1600		
B011	1	AM03854	Heat exchanger	MX 25,100,L=1600		
B014	1	AM01246	Combination filter	6.60.1, 34micr abs, DN 50		
B015	1	AM01226	By pass filter	Built on combination filter		
B016	1	AM00027	Viscometer, viscosense 2002	0..50 mPas +PCB (In box)+Cable	0-50 mPas=4..20 mA	
B016A	1	AM00023	Viscometer housing	Viscosense, DN 65 PN40		
B023	1	AM01410	Strainer	Fig 821-GG, 400micr abs, DN 40		
B024	1	AM01790	Steam trap	TD 52, R1"		
B025	1	AM01790	Steam trap	TD 52, R1"		
B026	1	AM01787	Steam trap	TD 52 LC, R 1/2"		
D001	1	AM00828	Feeder Pump	ACG 045K7/ NTBP (No bracket), DN 50		12.9m ³ /h, 4bar, 75cSt
D002	1	AM00828	Feeder Pump	ACG 045K7/ NTBP (No bracket), DN 50		12.9m ³ /h, 4bar, 75cSt
D003	1	AM00840	Booster Pump	ACG 052N7/ NTBP (No bracket), DN 65		24m ³ /h, 4/10bar, 25.8 cSt
D004	1	AM00840	Booster Pump	ACG 052N7/ NTBP (No bracket), DN 65		24m ³ /h, 4/10bar, 25.8 cSt
D010	1	AM03855	Homogenizer	Lemag Slashpol H12		
E001	1	AM02659	Limit switch	Automax WDB 0101201		
L001	1	AM03600	Level switch	Liquiphant FTL20-061B, R1"		
M001	1	AM03165	El. motor	7AA 112M02 4,6kW, 3500rpm, B5		
M002	1	AM03165	El. motor	7AA 112M02 4,6kW, 3500rpm, B5		
M003	1	A066073	El. motor	7AA 132M02V 12.6kW, 3500rpm, B5		
M004	1	A066073	El. motor	7AA 132M02V 12.6kW, 3500rpm, B5		
P001	1	AM00091	Pressure gauge	213.53.63.-1..+3 bar, 63x1/4"		
P002	1	AM00091	Pressure gauge	213.53.63.-1..+3 bar, 63x1/4"		
P003	1	AM00086	Pressure gauge	213.53.63. 0..16 bar, 63x1/4"		
P004	1	AM00186	Pressure switch	MBC 5100-2431-2CB04 1-10 bar	1..10 bar	3 bar
P006	1	AM00086	Pressure gauge	213.53.63. 0..16 bar, 63x1/4"		
P007	1	AM00186	Pressure switch	MBC 5100-2431-2CB04 1-10 bar	1..10 bar	8 bar
P009	1	AM00086	Pressure gauge	213.53.63. 0..16 bar, 63x1/4"		
P011	1	AM01257	Diff. press. switch, filter autom.	DDA 4.36.2-08	0.6/0.8 bar	0.6/0.8 bar
P011A	1	AM01257	Diff. press. switch, filter autom.	DDA 4.36.2-08	0.6/0.8 bar	0.6/0.8 bar
Q001	1	AM04005	Flow meter	VZF-50 FL 130/25		

JNSY H2390-2393, H2403-2406

ITEM	QTY	PART NO	DESCRIPTION	TYPE/TECHNICAL DATA	SET RANGE	SET POINT
T001	1	AM00123	Thermometer	Jako fig 42S (-), R1/2", 0-160		
T002	1	AM00125	Thermometer	Jako fig 43S (L), R1/2", 0-160		
T005	1	AM00125	Thermometer	Jako fig 43S (L), R1/2", 0-160		
T006	1	AM00125	Thermometer	Jako fig 43S (L), R1/2", 0-160		
T007	1	AM01767	PT-100 sensor compact (1x)	CS12.221.903, 0..200, R 1/2"x75	0-200 °C	146 °C
V001	1	AM03872	3-way valve	776035L-DN80/85DA/NA54N-11-230V/WDB0101201		
V003	1	AM02947	Shut off valve	223 SGS/BW SCH 40, DN 50		
V004	1	AM02947	Shut off valve	223 SGS/BW SCH 40, DN 50		
V005	1	AM02756	Non return valve	GB-019, DN 40		
V006	1	AM02756	Non return valve	GB-019, DN 40		
V007	1	AM02947	Shut off valve	223 SGS/BW SCH 40, DN 50		
V008	1	AM02947	Shut off valve	223 SGS/BW SCH 40, DN 50		
V010	1	AM02837	Overflow valve	SPVF 50 C2F1A05, DN 50	2-5 bar	4 bar
V013	1	AM02947	Shut off valve	223 SGS/BW SCH 40, DN 50		
V014	1	AM02947	Shut off valve	223 SGS/BW SCH 40, DN 50		
V015	1	AM02796	Overflow valve	RHD42L2 bar 42-42		2 bar
V015A	1	AM02947	Shut off valve	223 SGS/BW SCH 40, DN 50		
V016	1	AM02926	Shut off valve	213 SGS/BW SCH 40, DN 65		
V017	1	AM02926	Shut off valve	213 SGS/BW SCH 40, DN 65		
V018	1	AM02758	Non return valve	GB-019, DN 65		
V019	1	AM02758	Non return valve	GB-019, DN 65		
V020	1	AM02926	Shut off valve	213 SGS/BW SCH 40, DN 65		
V021	1	AM02926	Shut off valve	213 SGS/BW SCH 40, DN 65		
V024	1	AM02926	Shut off valve	213 SGS/BW SCH 40, DN 65		
V025	1	AM02926	Shut off valve	213 SGS/BW SCH 40, DN 65		
V027	1	AM02870	Safety valve	851 BF-16, viton, R 1/2"	1-16 bar	15 bar
V028	1	AM02926	Shut off valve	213 SGS/BW SCH 40, DN 65		
V029	1	AM02926	Shut off valve	213 SGS/BW SCH 40, DN 65		
V031	1	AM02870	Safety valve	851 BF-16, viton, R 1/2"	1-16 bar	15 bar
V032	1	AM02947	Shut off valve	223 SGS/BW SCH 40, DN 50		
V033	1	AM02947	Shut off valve	223 SGS/BW SCH 40, DN 50		
V034	1	AM02796	Overflow valve	RHD42L2 bar 42-42		2 bar
V035	1	AM02947	Shut off valve	223 SGS/BW SCH 40, DN 50		
V036	1	AM02926	Shut off valve	213 SGS/BW SCH 40, DN 65		
V037	1	AM02926	Shut off valve	213 SGS/BW SCH 40, DN 65		

JNSY H2390-2393, H2403-2406

ITEM	QTY	PART NO	DESCRIPTION	TYPE/TECHNICAL DATA	SET RANGE	SET POINT
V038	1	AM02926	Shut off valve	213 SGS/BW SCH 40, DN 65		
V043	1	AM01684	Automatic air vent	Minox-G 8070, R 1/2"		
V044	1	AM02975	Shut off valve	223 SGS/SC, R 1/2"		
V046	1	AM02866	Safety valve	851 BF-10, viton, R 1/2"		
V051	11	AM03036	Shut off valve	RB-1720, R 1/4"		
V052	3	AM03035	Shut off valve	RB-1720, R 1/2"		
V078	1	AM01348	Shut off valve	Built on combination filter		
V078A	1	AM01348	Shut off valve	Built on combination filter		
V081	1	AM02975	Shut off valve	223 SGS/SC, R 1/2"		
V082	1	AM02570	Globe valve	Fig 215-01 (-), DN 40		
V085	1	AM02592	Globe valve	Fig 216-01 (L), DN 40		
V086	1	AM03722	Motor control valve	KE 73+EL5611(220) DN40/KV16		
V087	1	AM02570	Globe valve	Fig 215-01 (-), DN 40		
V088	1	AM02946	Shut off valve	223 SGS/BW SCH 40, DN 40		
V089	1	AM02944	Shut off valve	223 SGS/BW SCH 40, DN 25		
V090	1	AM02946	Shut off valve	223 SGS/BW SCH 40, DN 40		
V091	1	AM02944	Shut off valve	223 SGS/BW SCH 40, DN 25		
V092	1	AM02975	Shut off valve	223 SGS/SC, R 1/2"		

ITEM	QTY	PART NO	DESCRIPTION	TYPE/TECHNICAL DATA
SP01	1	AF00476	CONTACTOR	100-C12KF10
SP02	1	AF00479	CONTACTOR	100-C30KF10
SP03	2	AF00428	MINIATURE RELAY	40.52.8.230
SP04	6	AF00883	INDICATING LIGHT	CL-523G
SP05	2	AF00882	INDICATING LIGHT	CL-523R
SP06	2	AF00880	INDICATING LIGHT	CL-523W
SP07	1	AM00091	PRESSURE GAUGE	213.53.63.-1...+3bar, 63x1/4"
SP08	1	AM00086	PRESSURE GAUGE	213.53.63.0...+16bar, 63x1/4"
SP09	1	AM01217	BASKET ELEMENT	D60,290/480,PRI-4936-3
SP10	2	AG00816	BALL BEARINGS for M001,M002	6306-ZZ C3
SP11	2	AG00817	BALL BEARINGS for M003,M004	6308-ZZ CS
SP12	1	AM00123	THERMOMETER	JAKO FIG 42S (-), R1/2",0-160
SP13	1	AM00125	THERMOMETER	JAKO FIG 43S (L), R1/2",0-160
SP14	1	AM00004	FLANGE GASKETS	ACG 045
SP15	1	AM00005	FLANGE GASKETS	ACG 052
SP16	1	AM00006	FLANGE GASKETS	BOLL 6.60.1 DN50
SP17	1	AG00971	REGULATING SPRING	SPVF50, 2...5 bar

SECTION 3

3 Electric diagrams, Part list

WIDTH 600
 HEIGHT 380
 DEPTH 210
 COLOR RAL 7035

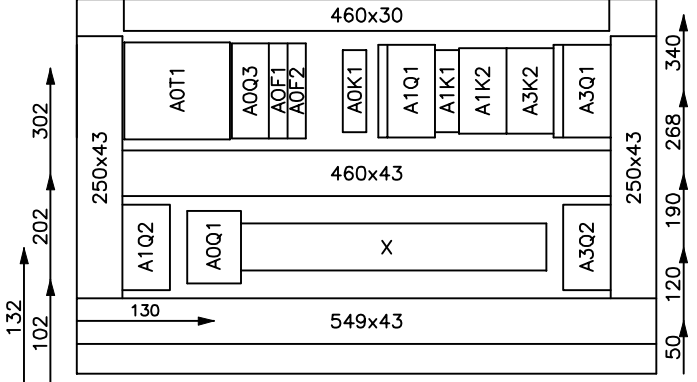
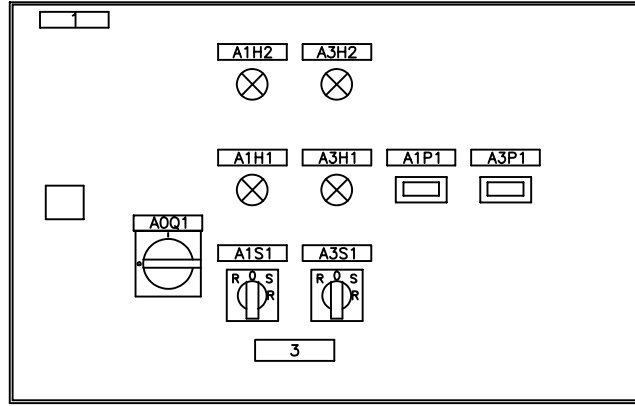

150 230 310 390 470

8xM20+M25

FOR SITE CABLES:
 2xM20+3xM25

LIST OF LABELS

id	pcs	text
1	1	STARTER 1
AOQ1	1	MAIN SWITCH
A1S1	1	FEEDER PUMP D001
A3S1	1	BOOSTER PUMP D003
-H1	2	RUNNING
-H2	2	TRIPPED
A1P1	1	RUNNING HOURS OF FEEDER PUMP D001
-	-	
A3P1	1	RUNNING HOURS OF BOOSTER PUMP D003
-	-	
3	1	WARNING ELECTRIC MOTORS WILL START AUTOMATICALLY AFTER POWER FAILURE

AC 440V 60Hz

a Pump interlocking and UVR function added 4.1.2007 ARu





Product	AMB-M	CAD/SCALE	ARu/Rusanen
MADE	22.09.2006	ARu/Rusanen	
CHKD.	22.09.2006	ARu/Rusanen	
APPVD.	22.09.2006	RTu/Tuominen	

HUA HAI EQUIPMENT & ENG.
 JNSY H2390-3, H2403-6
 M/E

BOOSTER UNIT STARTER 1
 -
 Assembly Drawing

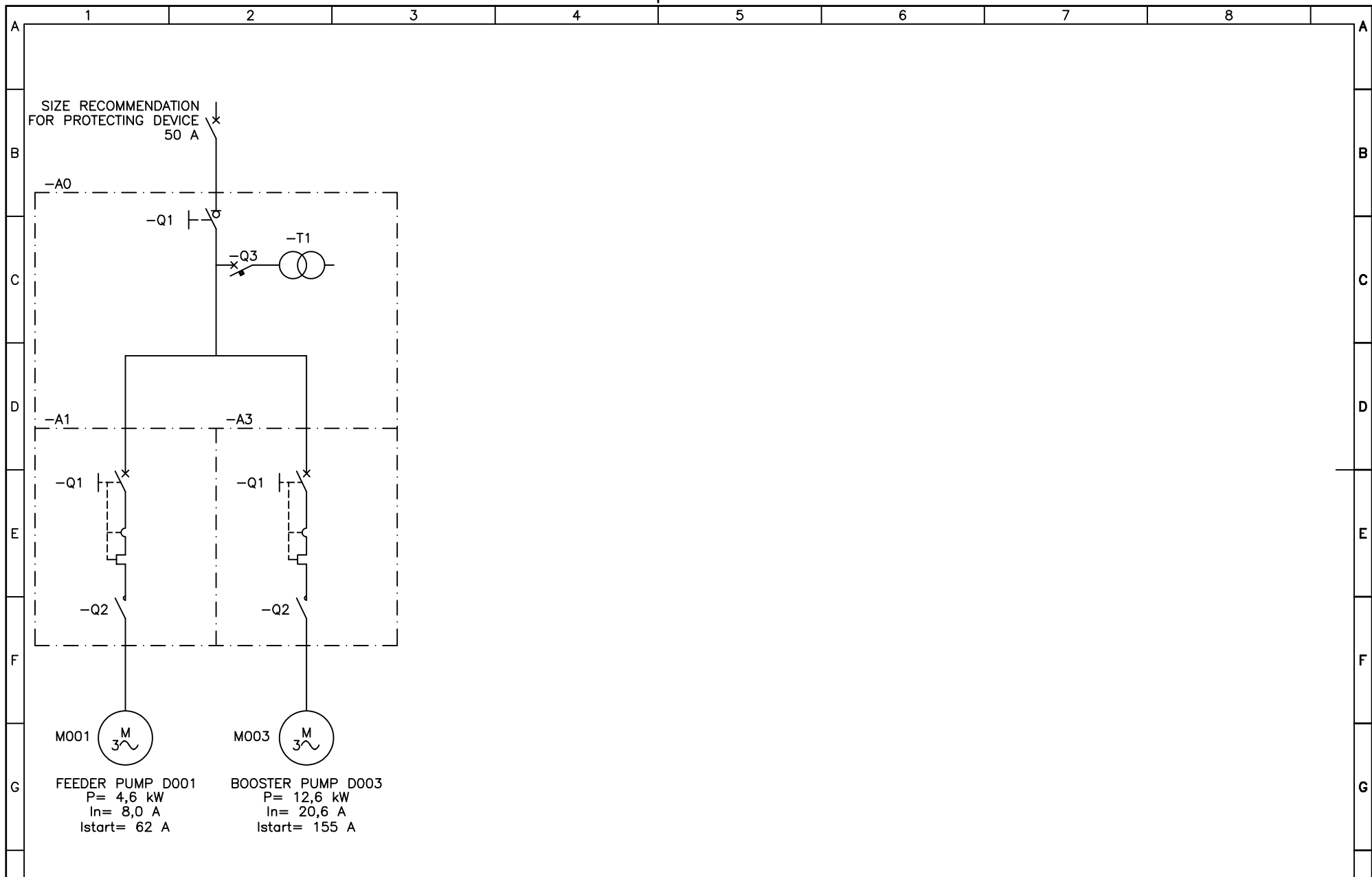
OBJECT	= E 1 DDC	Pg. number	
Lang	GB	Suppl. ident.	7324-7338
PROJECT #	-	A3-DRAWING #	407439
		SHEET	1 OF 31 SHEETS
		REV.	A



 AURAMARINE AURAMARINE Ltd FINLAND	Product	AMB-M	CAD	SCALE	HUA HAI EQUIPMENT & ENG. JNSY H2390-3, H2403-6 M/E	BOOSTER UNIT STARTER 1 POWER DISTRIBUTION Single Line Diagram	OBJECT	= E 1 DDC	Pg. Cnt.	number SHEET 2 OF SHEETS 31 REV. A	
	MADE	22.09.2006	ARu/Rusanen				LnG	Suppl. 7324-7338	SHEET		2
	CHKD.	22.09.2006	ARu/Rusanen				PROJECT #	A3-DRAWING #			
	APPVD.	22.09.2006	RTu/Tuominen					407439			

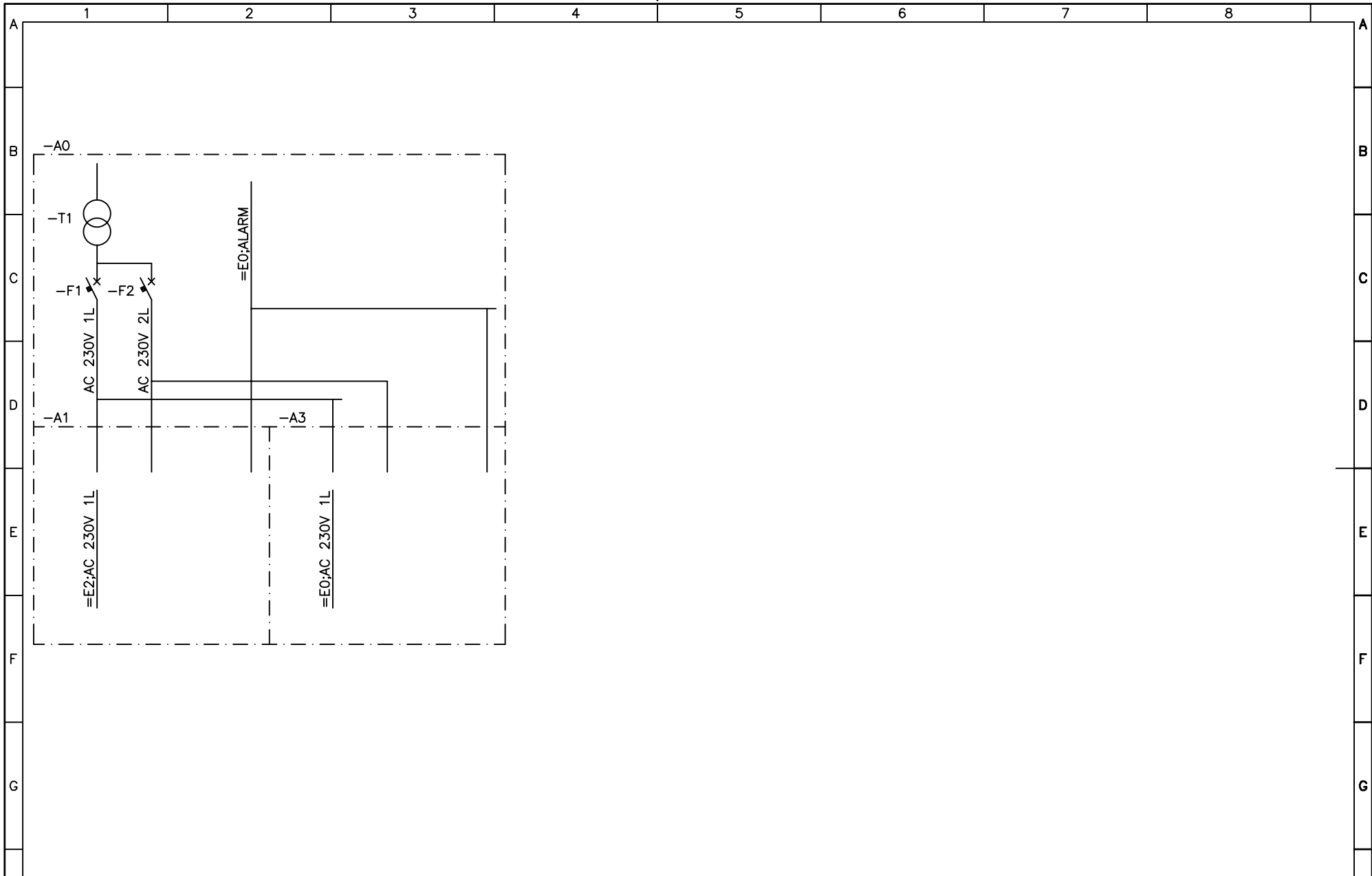

 AURAMARINE AURAMARINE Ltd FINLAND	Product	AMB-M	CAD SCALE	HUA HAI EQUIPMENT & ENG. JNSY H2390-3, H2403-6 M/E	BOOSTER UNIT STARTER 1 CONTROL VOLTAGE DISTRIBUTION Single Line Diagram	OBJECT	=E1DDC	Pg. Cnt.	number 31 SHEETS 31			
	MADE	22.09.2006	ARu/Rusanen			Lng	GB	Suppl.		7324-7338	SHEET	3
	CHKD.	22.09.2006	ARu/Rusanen			PROJECT #	-	A3-DRAWING #		407439	REV.	A
	APPVD.	22.09.2006	RTu/Tuominen									

a Pump interlocking added 4.1.2007 ARU

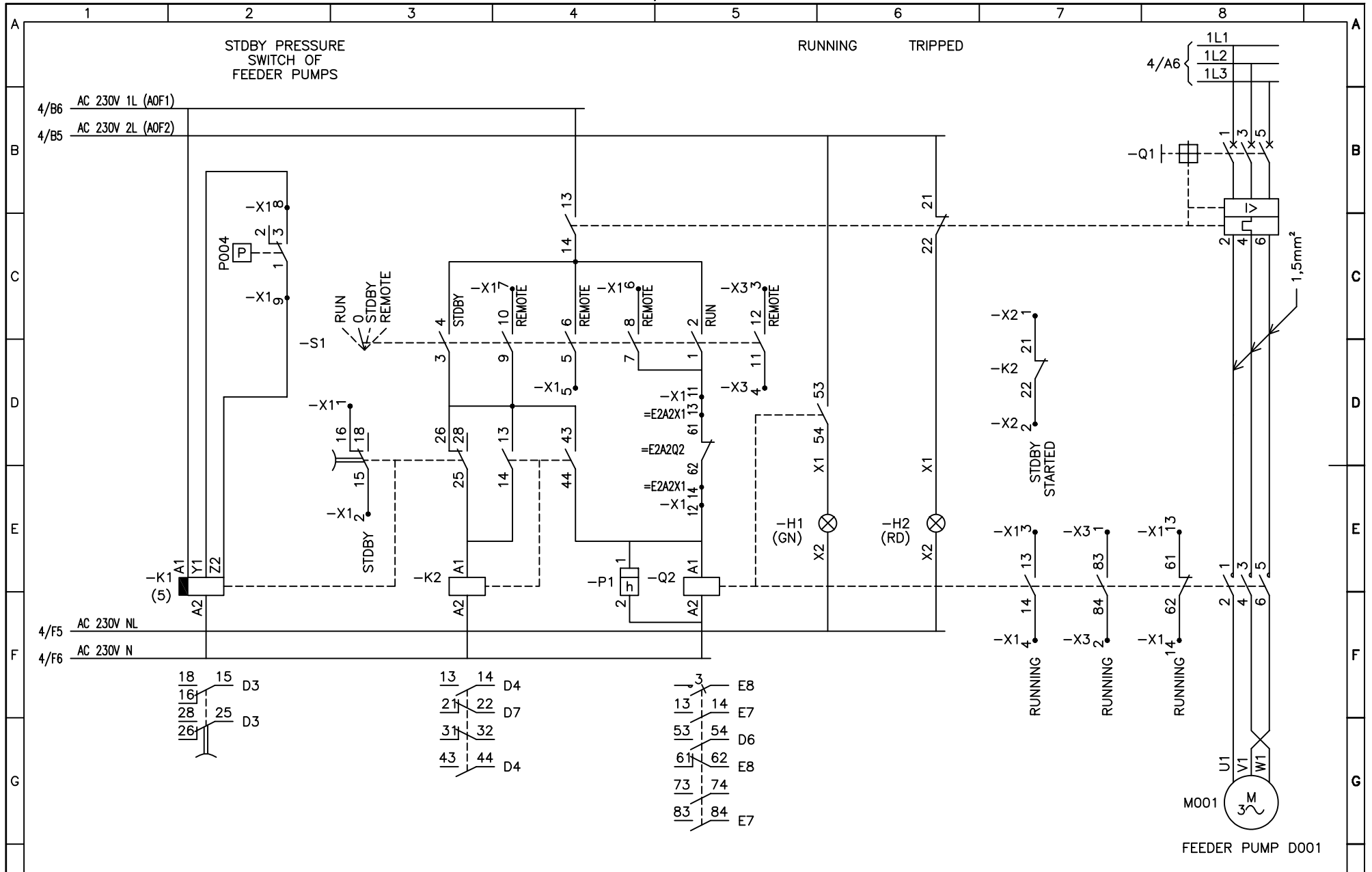

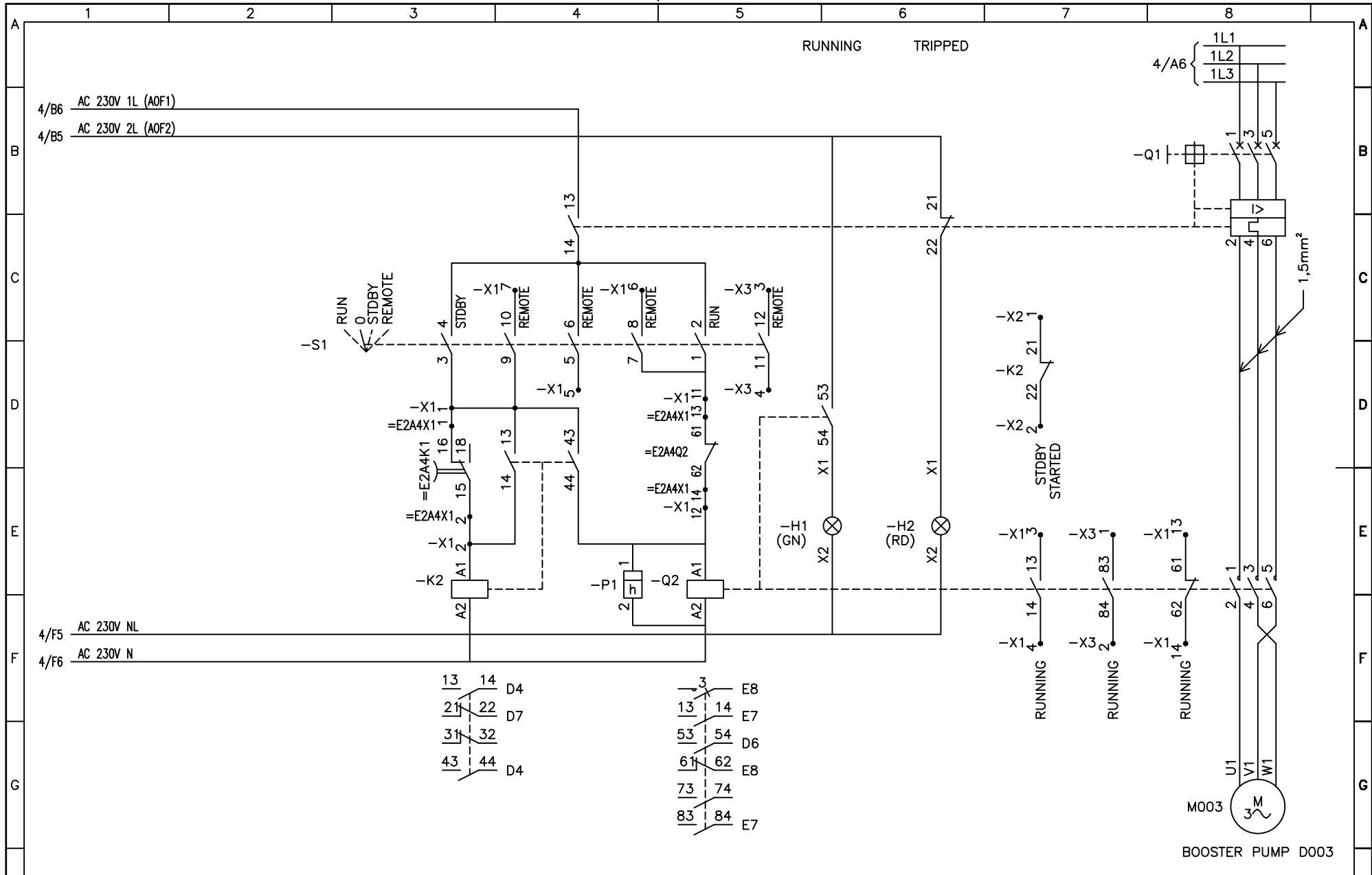

<p>AURAMARINE AURAMARINE Ltd FINLAND</p>	Product	AMB-M	CAD/SCALE	HUA HAI EQUIPMENT & ENG.	BOOSTER UNIT STARTER 1	OBJECT	=E1-A1 DDC	Pg. Cnt.	number
	MADE	22.09.2006	ARu/Rusanen	JNSY H2390-3, H2403-6	FEEDER PUMP D001	Lng/GB/Suppl.	7324-7338	SHEET	5 OF 31
	CHKD.	22.09.2006	ARu/Rusanen	M/E	Circuit Diagram	PROJECT #	A3-DRAWING #	SHEETS	REV.
	APPVD.	22.09.2006	RTu/Tuominen				407439		A

a Pump interlocking added 4.1.2007 ARU

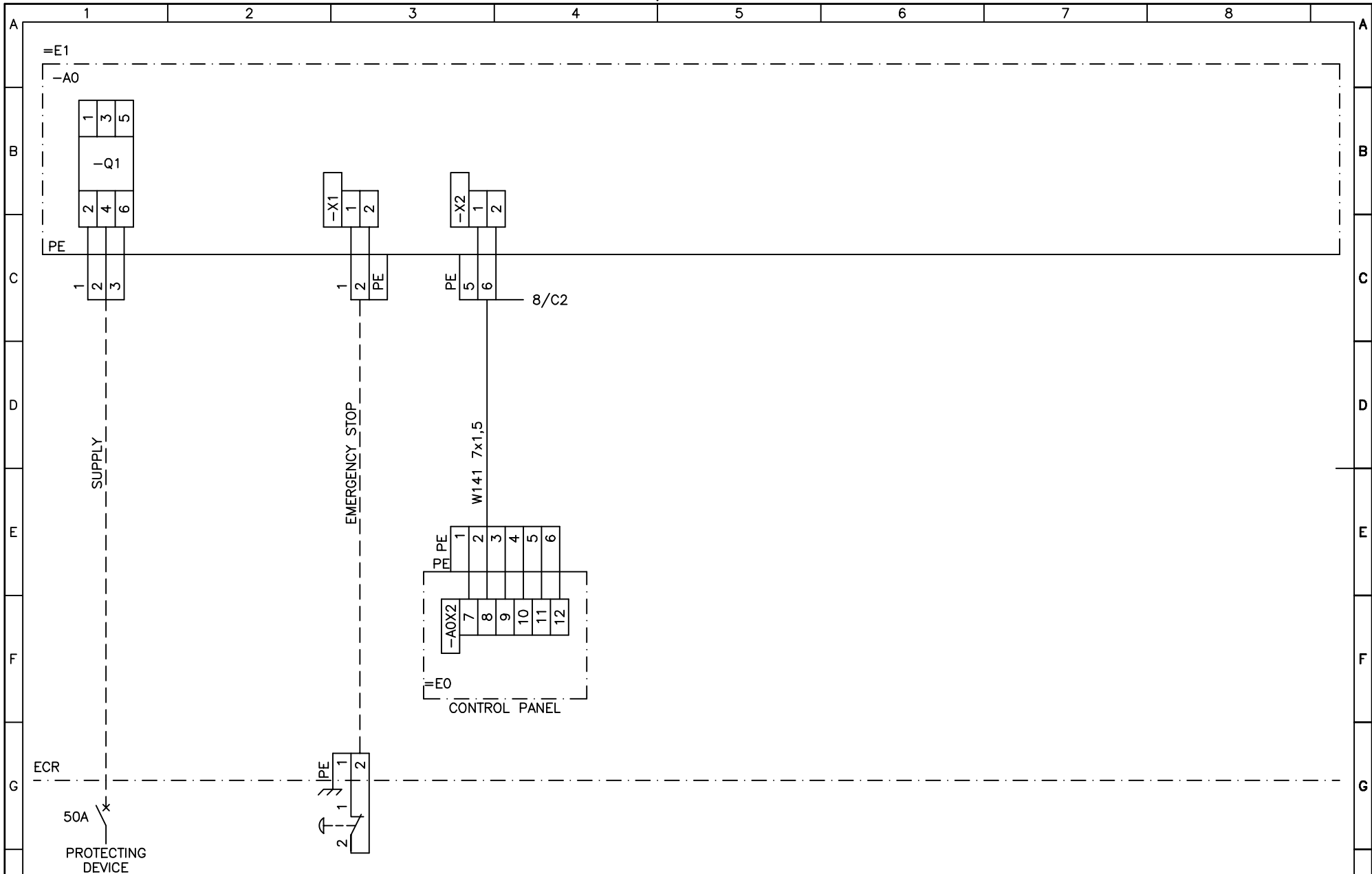

<p>AURAMARINE AURAMARINE Ltd FINLAND</p>	Product	AMB-M	CAD SCALE	HUA HAI EQUIPMENT & ENG.	BOOSTER UNIT STARTER 1	OBJECT	=E1-A3 DDC	Pg. Cnt.	number
	MADE	22.09.2006	ARu/Rusanen	JNSY H2390-3, H2403-6	BOOSTER PUMP D003	Lang	GB	Suppl.	7324-7338
	CHKD.	22.09.2006	ARu/Rusanen	M/E	Circuit Diagram	PROJECT #	A3-DRAWING #	SHEET	6 OF SHEETS
	APPVD.	22.09.2006	RTu/Tuominen				407439	REV.	A



 AURAMARINE AURAMARINE Ltd FINLAND	Product	AMB-M	 SCALE	HUA HAI EQUIPMENT & ENG.	BOOSTER UNIT STARTER 1	OBJECT	=E1 DDC	Pg. number	
	MADE	22.09.2006	ARu/Rusanen	JNSY H2390-3, H2403-6	SUPPLY	Lng	GB	Suppl. 7324-7338	SHEET 7 OF SHEETS 31
	CHKD.	22.09.2006	ARu/Rusanen	M/E	Interconnection Diagram	PROJECT #	-	A3-DRAWING #	407439
	APPVD.	22.09.2006	RTu/Tuominen			REV.			A

a Pump interlocking added 4.1.2007 ARU

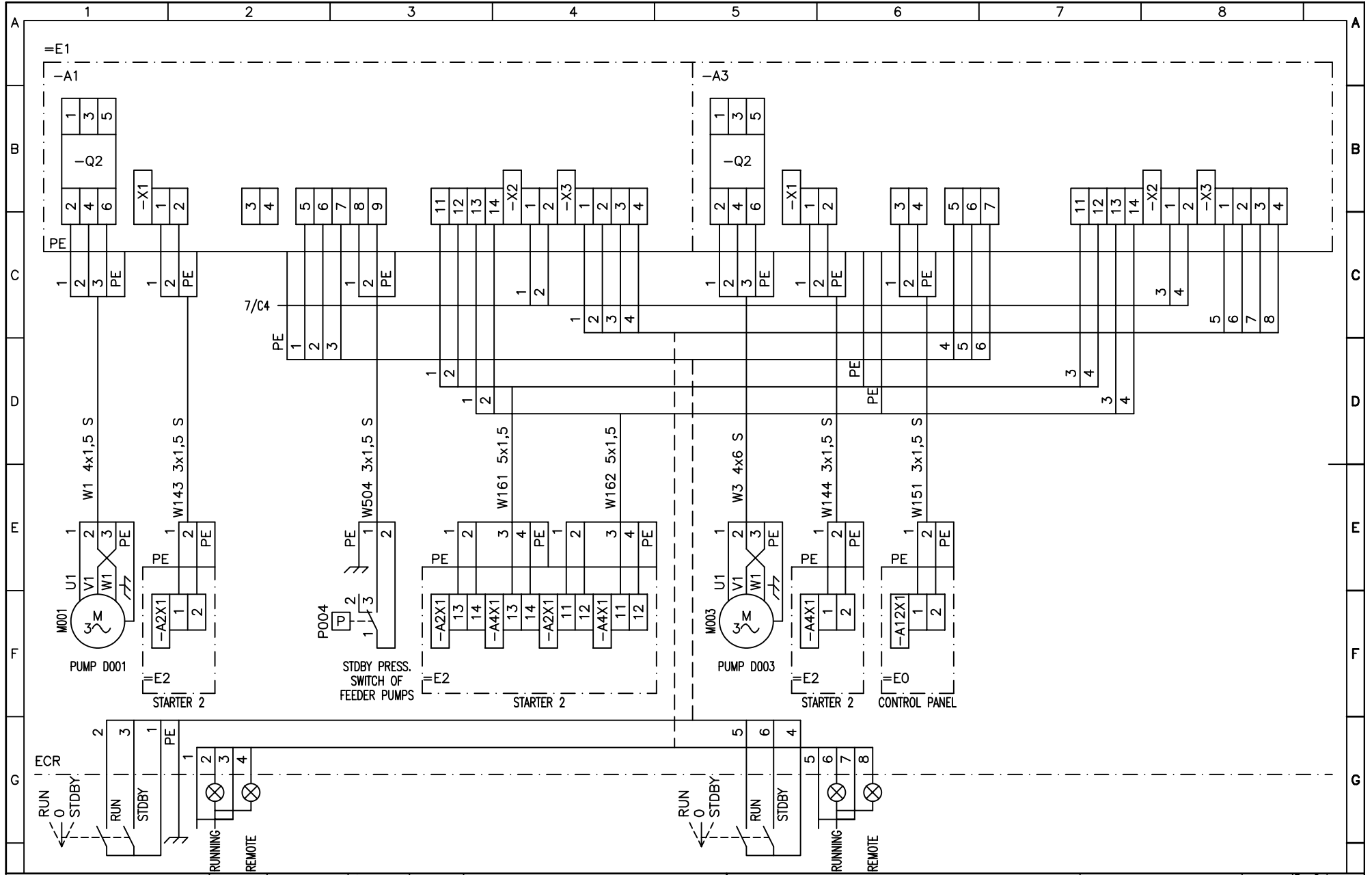

AURAMARINE
 AURAMARINE Ltd
 FINLAND

Product	AMB-M	CAD/SCALE
MADE	22.09.2006	ARu/Rusanen
CHKD.	22.09.2006	ARu/Rusanen
APPVD.	22.09.2006	RTu/Tuominen

HUA HAI EQUIPMENT & ENG.
 JNSY H2390-3, H2403-6
 M/E

BOOSTER UNIT STARTER 1
 PUMP MOTORS & SIGNALS
 Interconnection Diagram

OBJECT	=E1 DDC	Pg. number	8
Lang	GB	Suppl. ident.	7324-7338
PROJECT #	A3-DRAWING #	SHEET	8 OF SHEETS 31
-	407439	REV.	A

WIDTH 600
 HEIGHT 380
 DEPTH 210
 COLOR RAL 7035

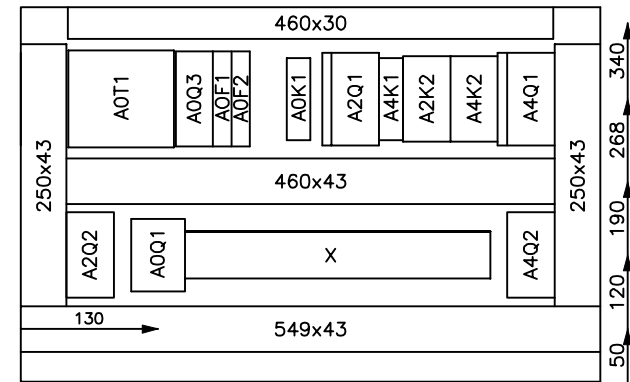
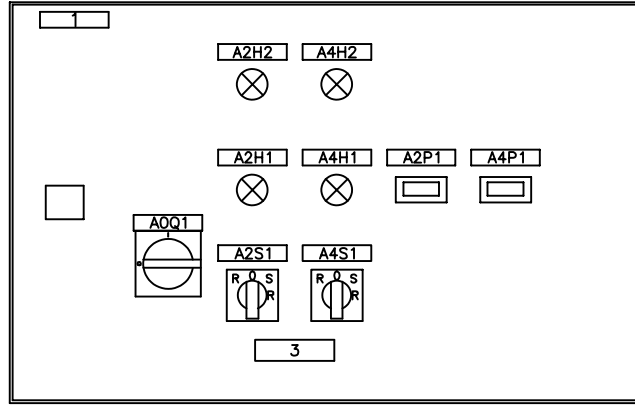

150 230 310 390 470

132
102
202
302

340
268
190
120
50

8xM20+M25

FOR SITE CABLES:
 2xM20+3xM25

LIST OF LABELS

id	pcs	text
1	1	STARTER 2
A0Q1	1	MAIN SWITCH
A2S1	1	FEEDER PUMP D002
A4S1	1	BOOSTER PUMP D004
-H1	2	RUNNING
-H2	2	TRIPPED
A2P1	1	RUNNING HOURS OF FEEDER PUMP D002
-	-	
A4P1	1	RUNNING HOURS OF BOOSTER PUMP D004
-	-	
3	1	WARNING

ELECTRIC MOTORS WILL START
 AUTOMATICALLY AFTER POWER FAILURE

AC 440V 60Hz

a Pump interlocking and UVR function added 4.1.2007 ARu





Product	AMB-M	CAD/SCALE	ARu/Rusanen
MADE	22.09.2006	ARu/Rusanen	
CHKD.	22.09.2006	ARu/Rusanen	
APPVD.	22.09.2006	RTu/Tuominen	

HUA HAI EQUIPMENT & ENG.
 JNSY H2390-3, H2403-6
 M/E

BOOSTER UNIT STARTER 2
 -
 Assembly Drawing

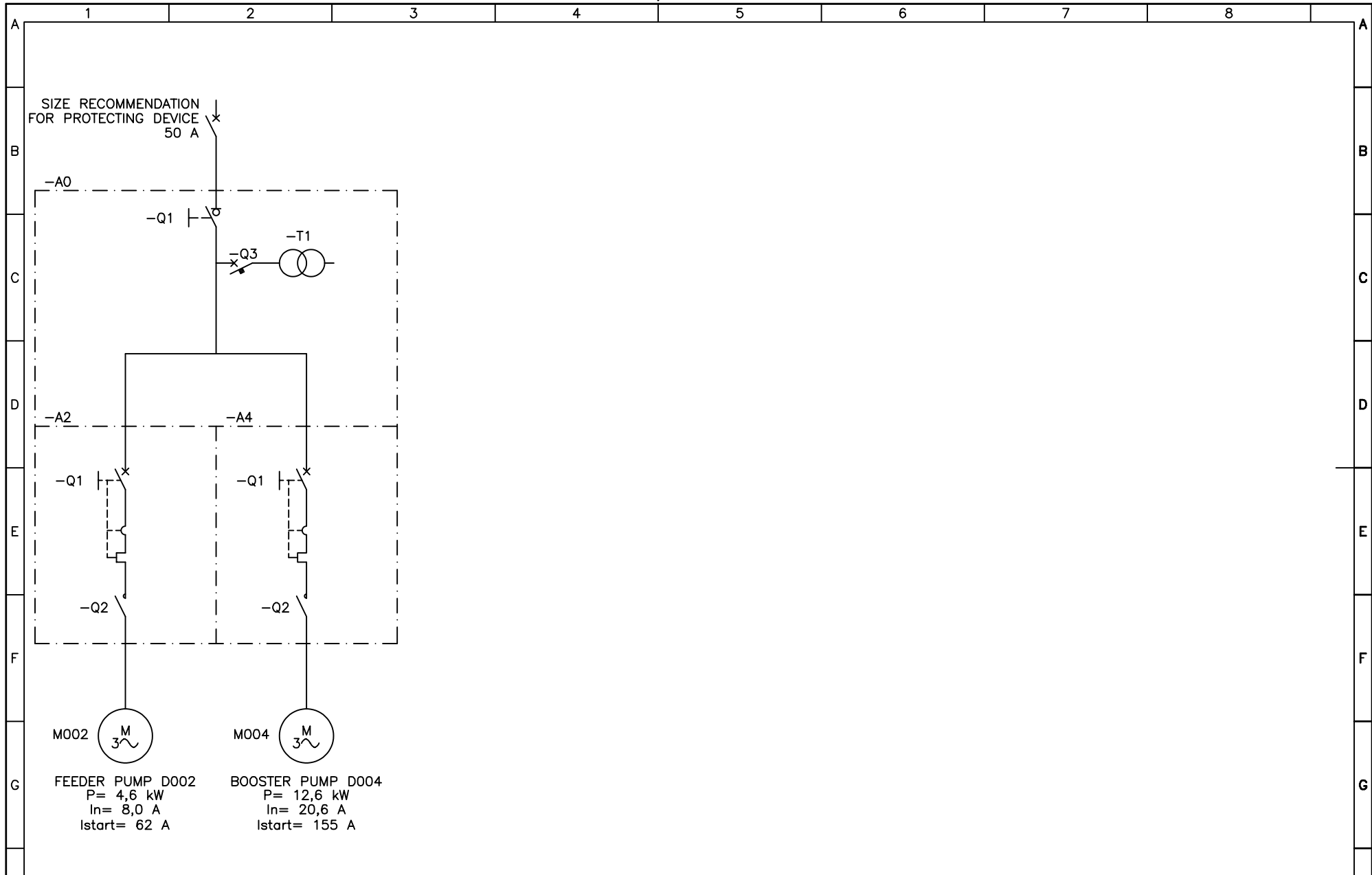
OBJECT	=E2 DDC	Pg. Cnt.	number
Lang	GB	Suppl. Ident.	7324-7338
PROJECT #	-	SHEET	9 OF SHEETS 31
	A3-DRAWING #	REV.	
	407439	A	



 AURAMARINE AURAMARINE Ltd FINLAND	Product	AMB-M	CAD	SCALE	HUA HAI EQUIPMENT & ENG. JNSY H2390-3, H2403-6 M/E	BOOSTER UNIT STARTER 2 POWER DISTRIBUTION Single Line Diagram	OBJECT	=E2	DDC	Pg. Cnt.	number		
	MADE	22.09.2006	ARu/Rusanen				LnG	CB	Suppl.	7324-7338	SHEET 10	OF	31
	CHKD.	22.09.2006	ARu/Rusanen				PROJECT #		A3-DRAWING #	407439	REV.		A
	APPVD.	22.09.2006	RTu/Tuominen										

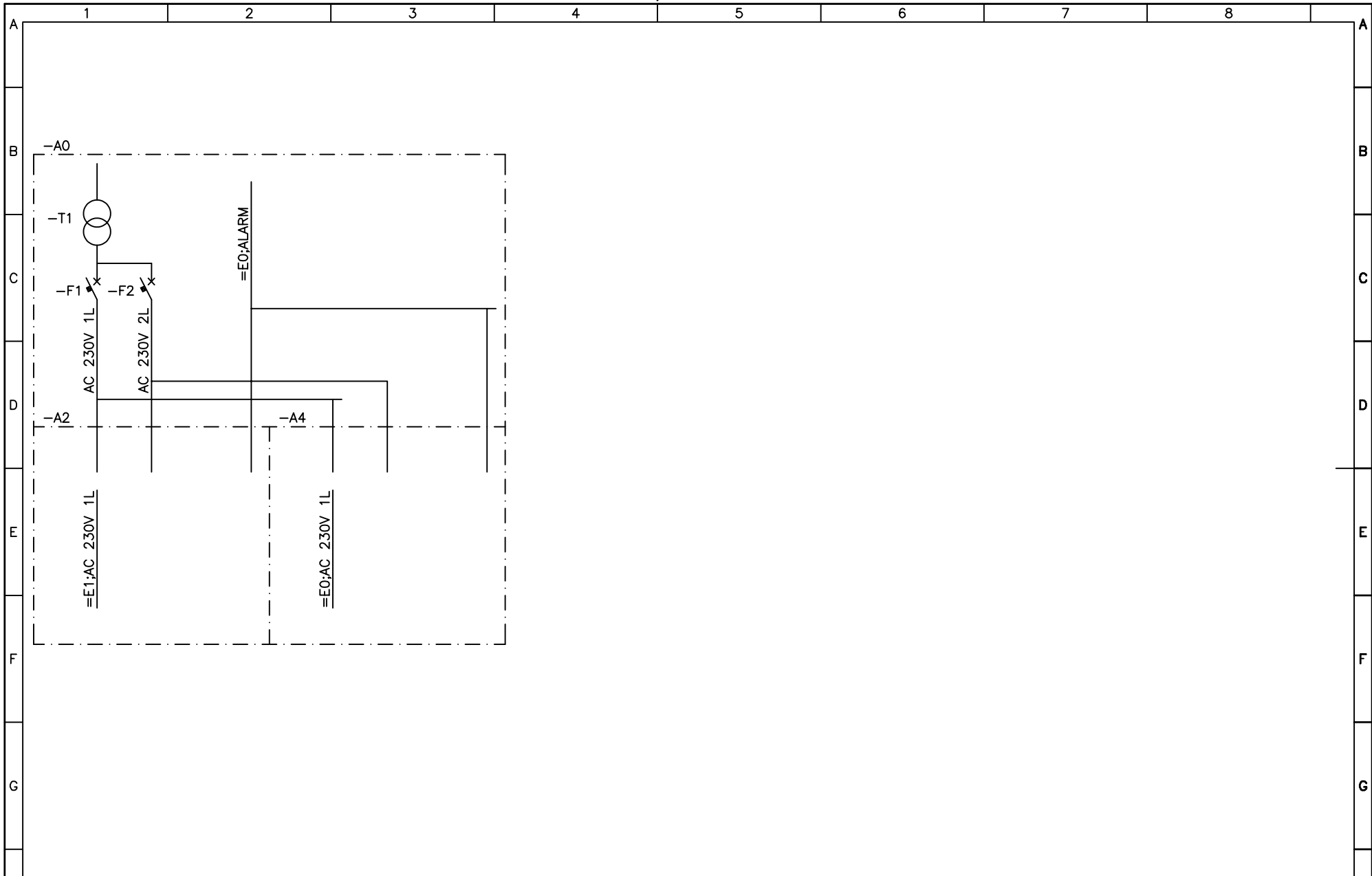

 AURAMARINE AURAMARINE Ltd FINLAND	Product	AMB-M	CAD	SCALE	HUA HAI EQUIPMENT & ENG. JNSY H2390-3, H2403-6 M/E	BOOSTER UNIT STARTER 2 CONTROL VOLTAGE DISTRIBUTION Single Line Diagram	OBJECT	=E2	DDC	Pg. Cnt.	SHEET 1 1 OF SHEETS 3 1 REV. A	
	MADE	22.09.2006	ARu/Rusanen				Lng	GB	Suppl.	7324-7338		
	CHKD.	22.09.2006	ARu/Rusanen				PROJECT #	-	A3-DRAWING #	407439		
	APPVD.	22.09.2006	RTu/Tuominen									

a Control voltage connection changed 4.1.2007 ARU

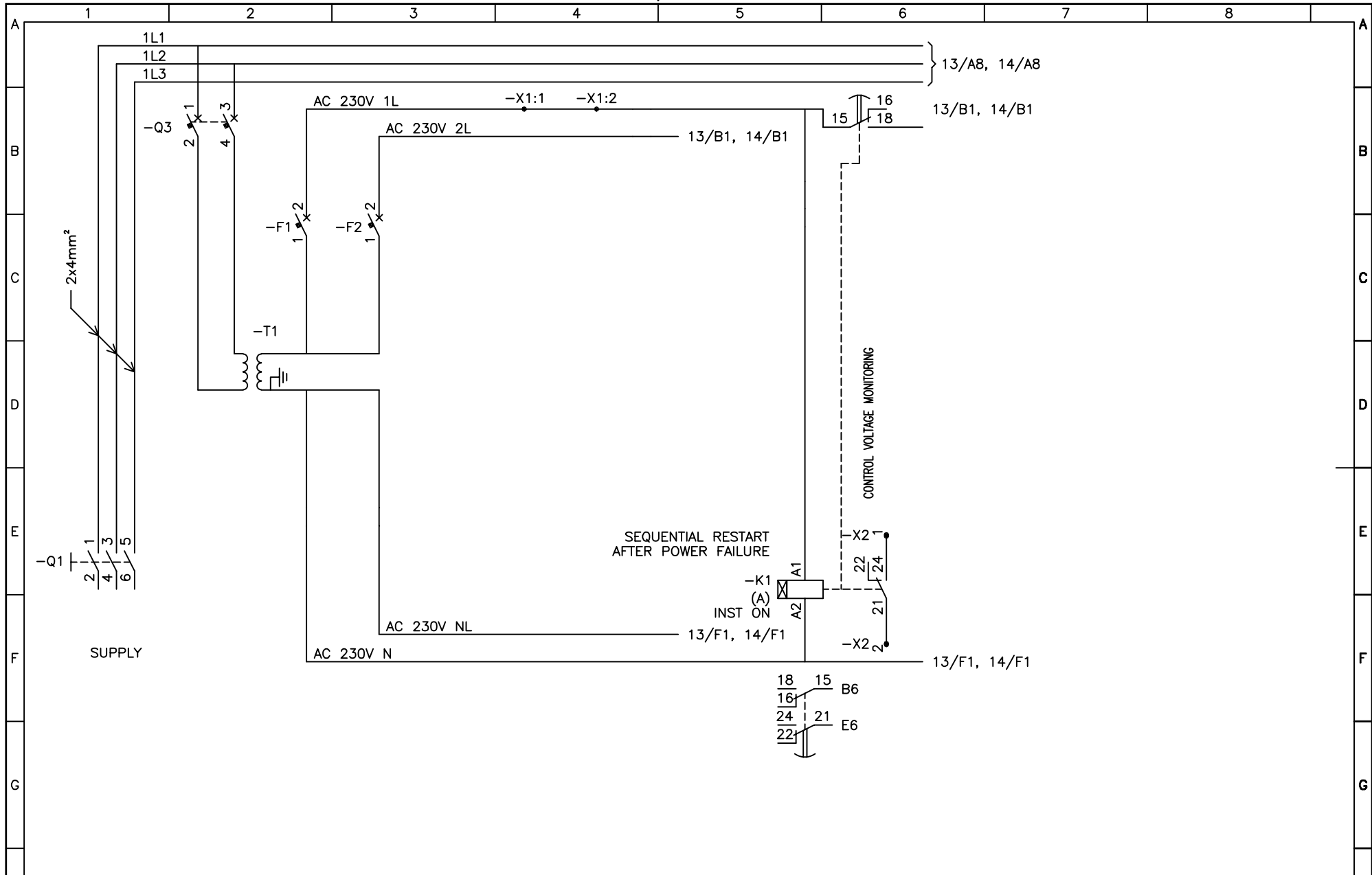

<p>AURAMARINE AURAMARINE Ltd FINLAND</p>	Product	AMB-M	CAD SCALE	HUA HAI EQUIPMENT & ENG. JNSY H2390-3, H2403-6 M/E	BOOSTER UNIT STARTER 2 SUPPLY Circuit Diagram	OBJECT	=E2-A0 DDC	Pg. Cnt.	number		
	MADE	22.09.2006	ARu/Rusanen			Lng	GB	Suppl.	7324-7338	SHEET	12
	CHKD.	22.09.2006	ARu/Rusanen			PROJECT #	-	A3-DRAWING #	407439	OF SHEETS	31
	APPVD.	22.09.2006	RTu/Tuominen			REV.	-				A

a Pump interlocking added 4.1.2007 ARU

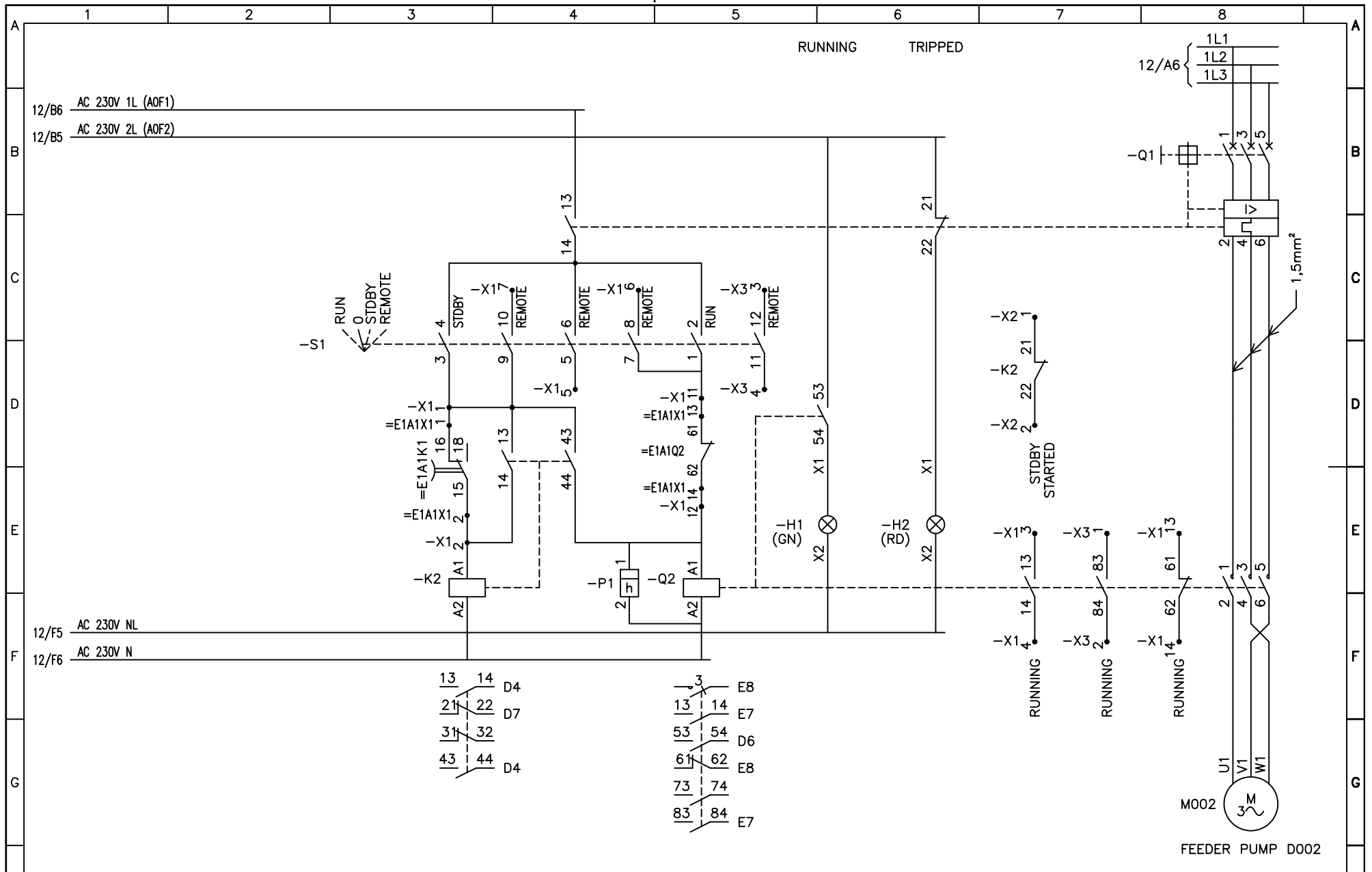

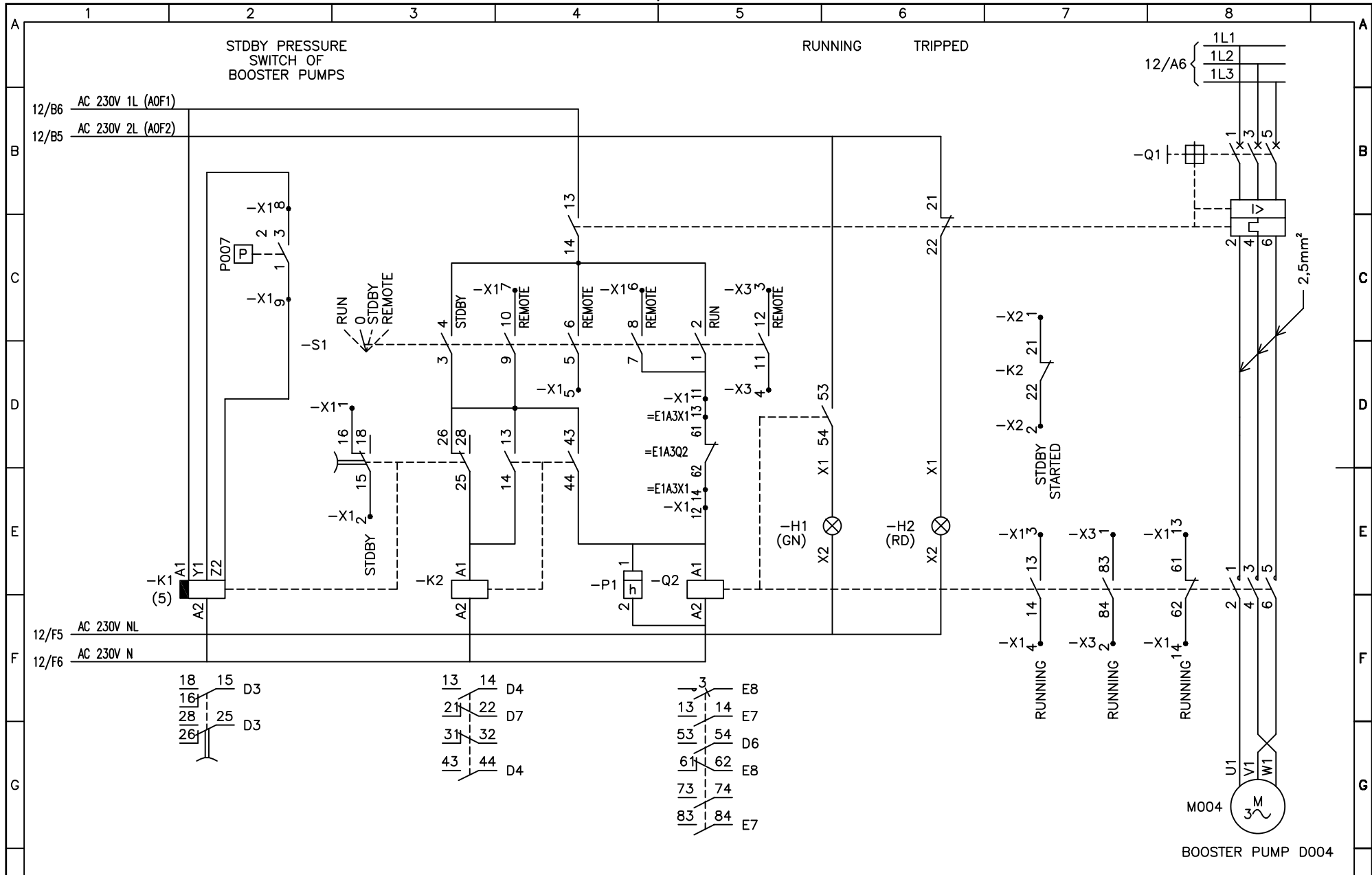

<p>AURAMARINE AURAMARINE Ltd FINLAND</p>	Product	AMB-M	CAD/SCALE	HUA HAI EQUIPMENT & ENG.	BOOSTER UNIT STARTER 2	OBJECT	=E2-A2 DDC	Pg. Cnt.	number
	MADE	22.09.2006	ARu/Rusanen	JNSY H2390-3, H2403-6	FEEDER PUMP D002	Lng GB Suppl.	7324-7338	SHEET 13	OF SHEETS 31
	CHKD.	22.09.2006	ARu/Rusanen	M/E	Circuit Diagram	PROJECT #	A3-DRAWING #	REV.	
	APPVD.	22.09.2006	RTu/Tuominen				407439	A	

a Pump interlocking added 4.1.2007 ARU

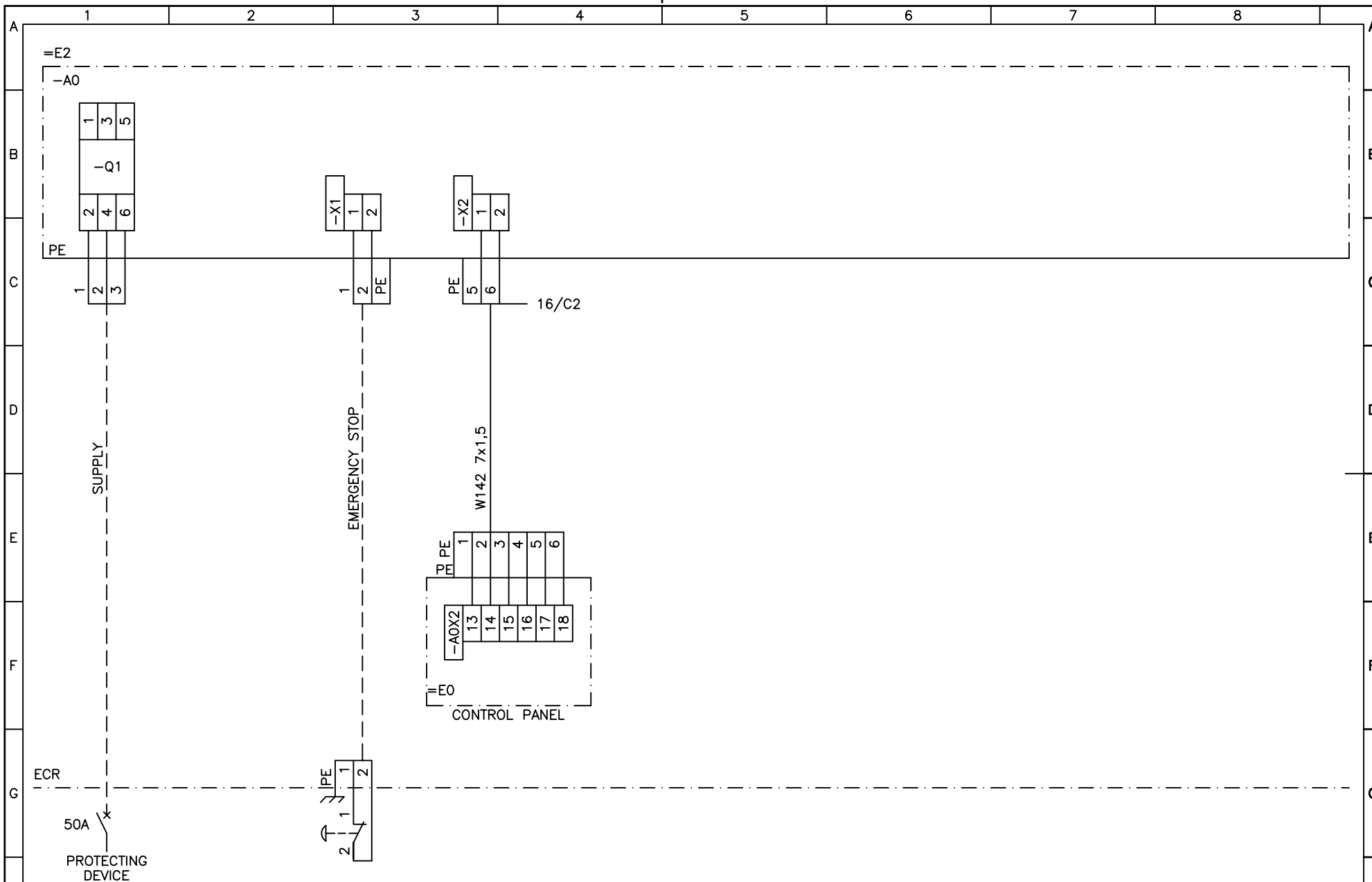

<p>AURAMARINE AURAMARINE Ltd FINLAND</p>	Product	AMB-M	CAD/SCALE	HUA HAI EQUIPMENT & ENG.	BOOSTER UNIT STARTER 2	OBJECT	=E2-A4 DDC	Pg. Cnt.	number
	MADE	22.09.2006	ARu/Rusanen	JNSY H2390-3, H2403-6	BOOSTER PUMP D004	Lng C Suppl.	7324-7338	SHEET	14 OF 31
	CHKD.	22.09.2006	ARu/Rusanen	M/E	Circuit Diagram	PROJECT #	A3-DRAWING #	REV.	
	APPVD.	22.09.2006	RTu/Tuominen				407439		



 AURAMARINE AURAMARINE Ltd FINLAND	Product	AMB-M	 SCALE	HUA HAI EQUIPMENT & ENG.	BOOSTER UNIT STARTER 2	OBJECT	=E2	Pg. Cnt.	
	MADE	22.09.2006	ARu/Rusanen	JNSY H2390-3, H2403-6	SUPPLY	LnG	7324-7338	number	
	CHKD.	22.09.2006	ARu/Rusanen	M/E	Interconnection Diagram	ident.	7324-7338	SHEET 15	OF 31
	APPVD.	22.09.2006	RTu/Tuominen			PROJECT #	A3-DRAWING #	REV.	
							407439	A	

a Pump interlocking added 4.1.2007 ARU

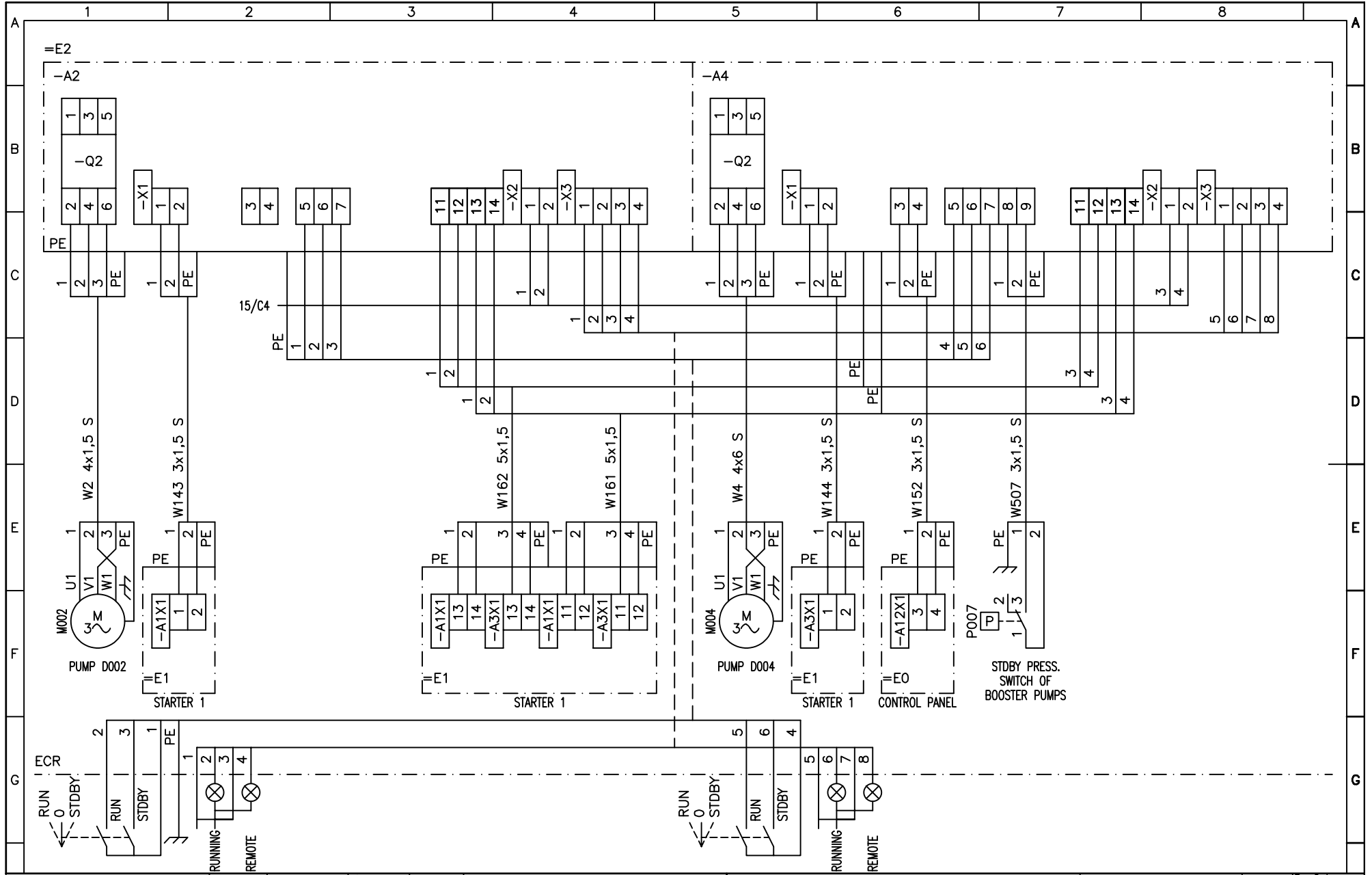

AURAMARINE
 AURAMARINE Ltd
 FINLAND

Product	AMB-M	CAD SCALE
MADE	22.09.2006	ARu/Rusanen
CHKD.	22.09.2006	ARu/Rusanen
APPVD.	22.09.2006	RTu/Tuominen

HUA HAI EQUIPMENT & ENG.
 JNSY H2390-3, H2403-6
 M/E

BOOSTER UNIT STARTER 2
 PUMP MOTORS & SIGNALS
 Interconnection Diagram

OBJECT	=E2 DDC	Pg. number
Lang	GB	Suppl. 7324-7338
PROJECT #	A3-DRAWING #	SHEET 16 OF SHEETS 31
-	407439	REV. A

a Flow meter changed, switch AOS4 corrected 4.1.2007 ARu

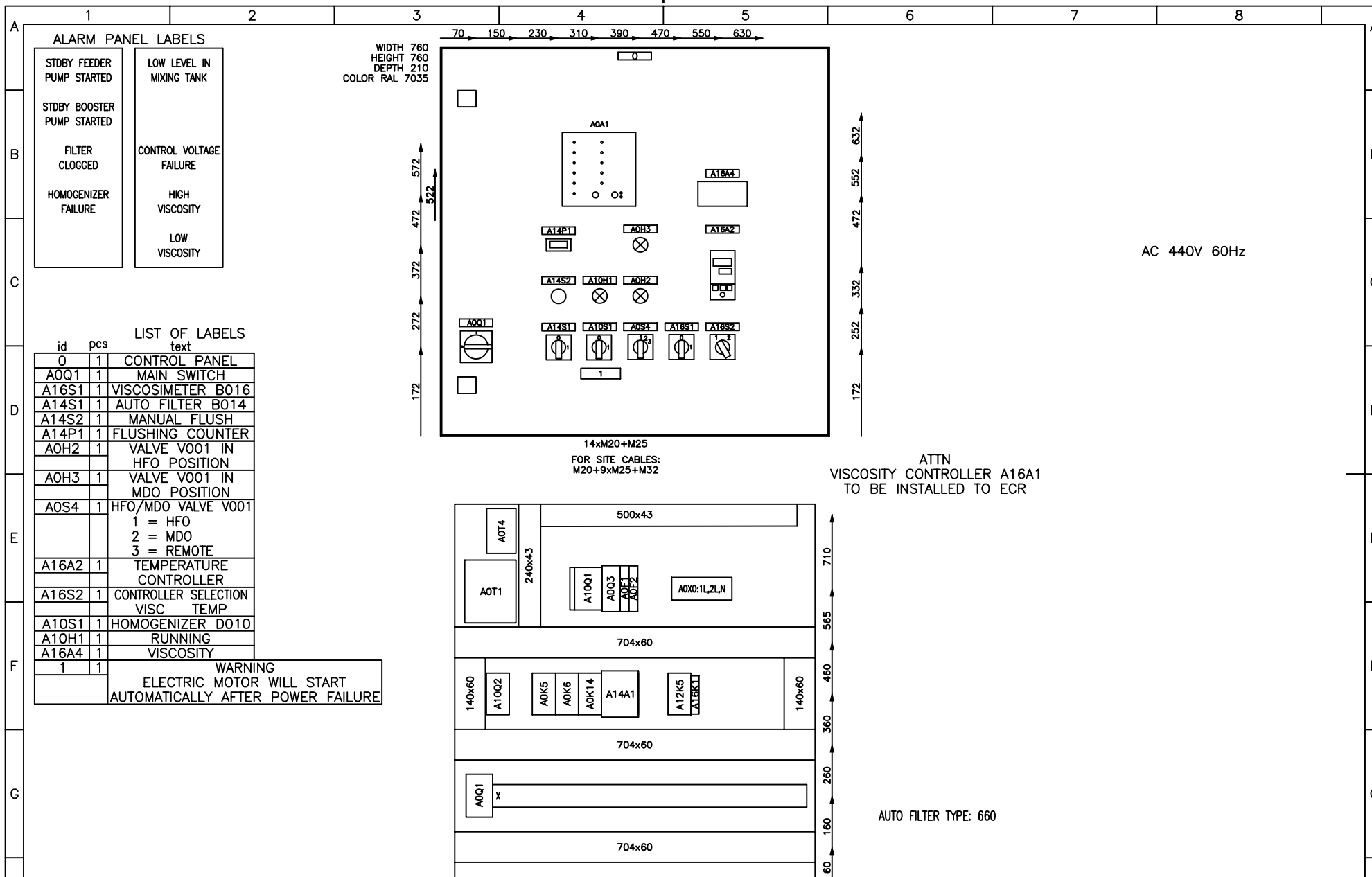

LIST OF LABELS

id	pcs	text
0	1	CONTROL PANEL
A0Q1	1	MAIN SWITCH
A16S1	1	VISCOSIMETER B016
A14S1	1	AUTO FILTER B014
A14S2	1	MANUAL FLUSH
A14P1	1	FLUSHING COUNTER
A0H2	1	VALVE V001 IN HFO POSITION
A0H3	1	VALVE V001 IN MDO POSITION
AOS4	1	HFO/MDO VALVE V001 1 = HFO 2 = MDO 3 = REMOTE
A16A2	1	TEMPERATURE CONTROLLER
A16S2	1	CONTROLLER SELECTION VISC TEMP
A10S1	1	HOMOGENIZER D010
A10H1	1	RUNNING
A16A4	1	VISCOSITY

WARNING
ELECTRIC MOTOR WILL START
AUTOMATICALLY AFTER POWER FAILURE



Product	AMB-M	CAD SCALE	
MADE	22.09.2006	ARu/Rusanen	
CHKD.	22.09.2006	ARu/Rusanen	
APPVD.	22.09.2006	RTu/Tuominen	

HUA HAI EQUIPMENT & ENG.
JNSY H2390-3, H2403-6
M/E

BOOSTER UNIT CONTROL PANEL
-
Assembly Drawing

OBJECT	=E0DDC	Pg. Cnt.	number
Lang	GB	Suppl. Ident.	7324-7338
PROJECT #		A3-DRAWING #	407439
		SHEET	17
		OF SHEETS	31
		REV.	A

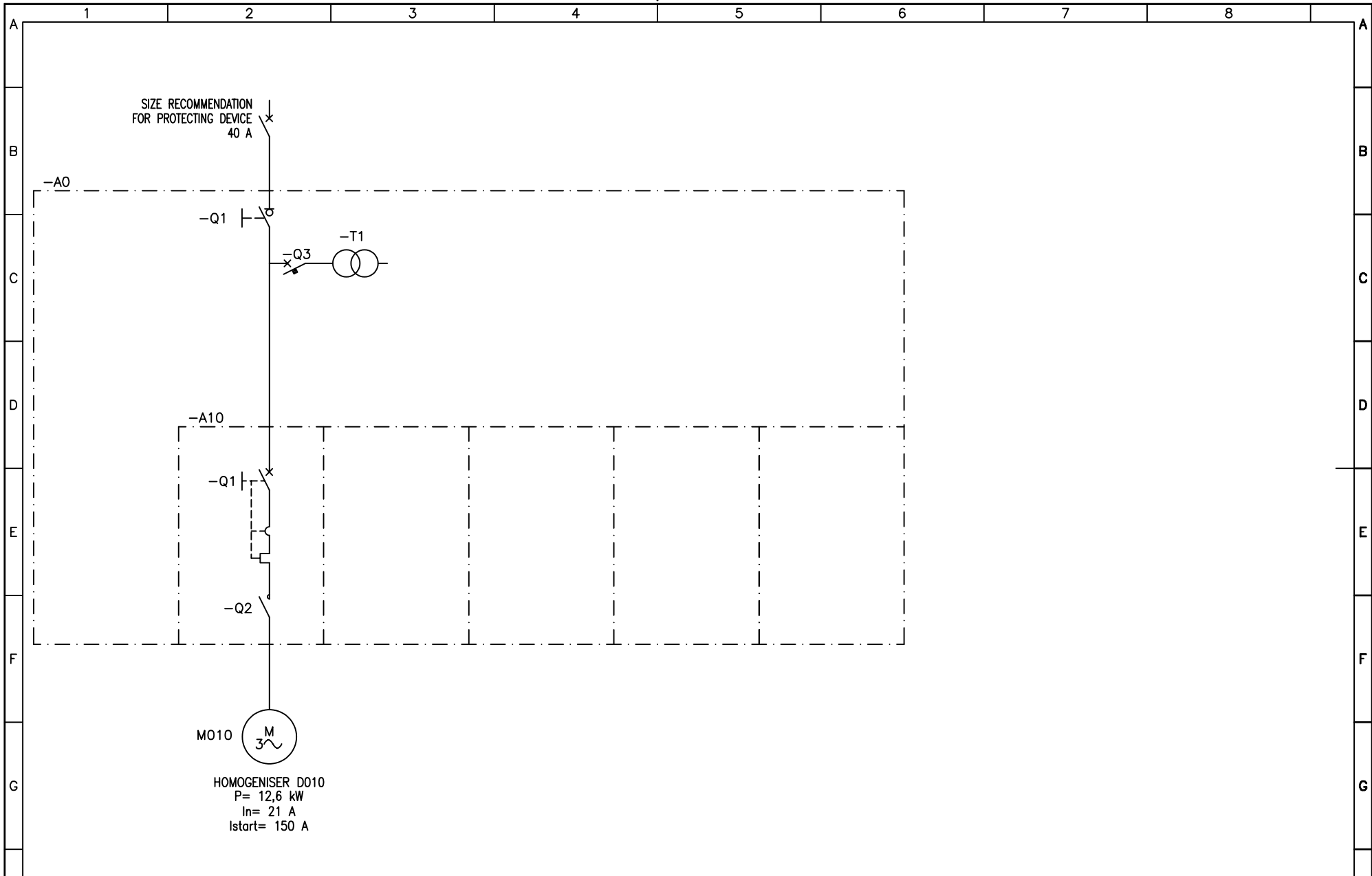

 AURAMARINE Ltd FINLAND	Product	AMB-M	CAD	SCALE	HUA HAI EQUIPMENT & ENG. JNSY H2390-3, H2403-6 M/E	BOOSTER UNIT CONTROL PANEL POWER DISTRIBUTION Single Line Diagram	OBJECT	=E0	DDC	Pg. Cnt.	number			
	MADE	22.09.2006	ARu/Rusanen				LnG	CB	Suppl.	7324-7338	SHEET	18	OF SHEETS	31
	CHKD.	22.09.2006	ARu/Rusanen				PROJECT #	-	A3-DRAWING #	407439	REV.	A		
	APPVD.	22.09.2006	RTu/Tuominen											

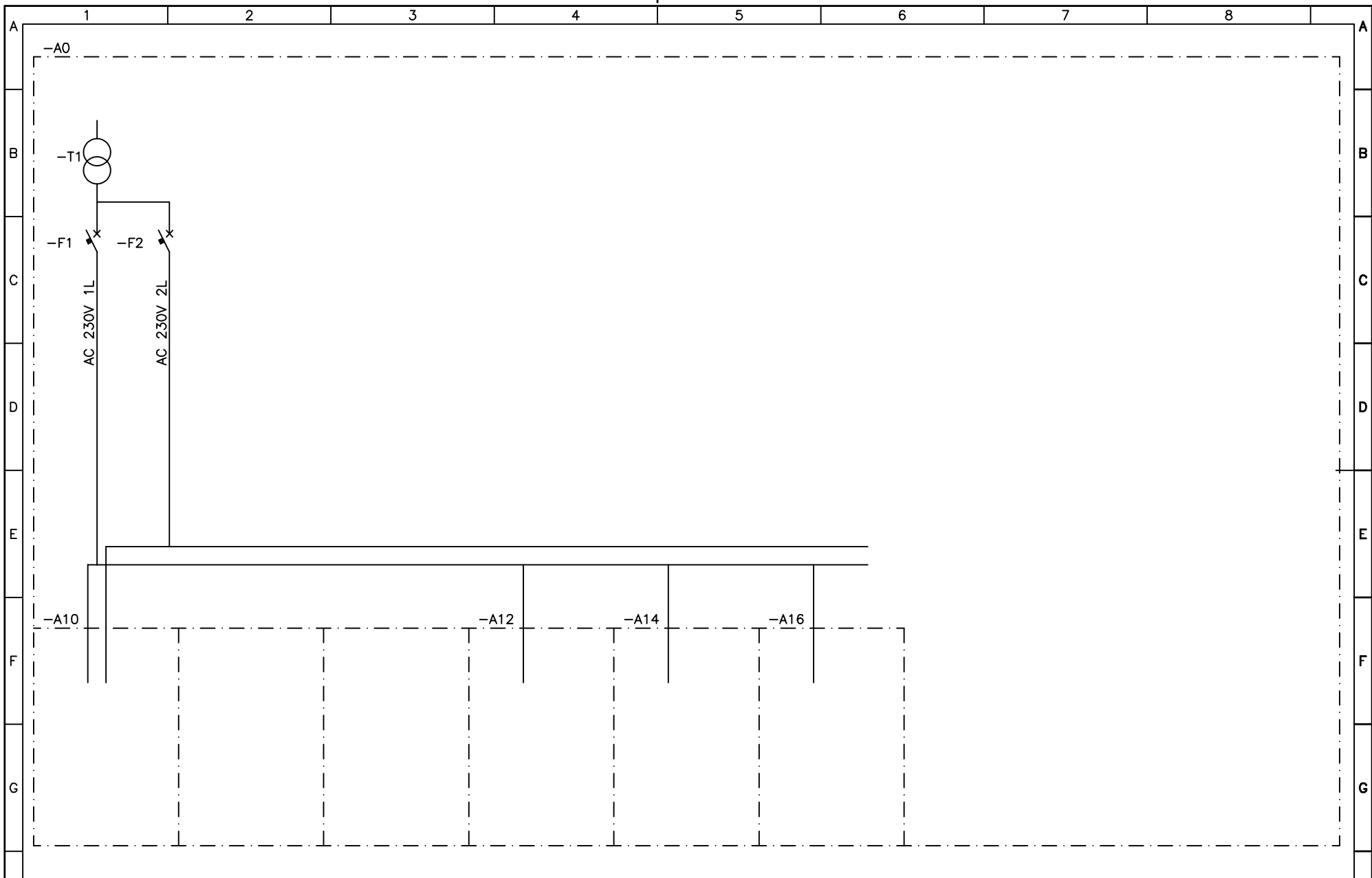

 AURAMARINE Ltd FINLAND	Product	AMB-M	CAD SCALE	HUA HAI EQUIPMENT & ENG.	BOOSTER UNIT CONTROL PANEL CONTROL VOLTAGE DISTRIBUTION Single Line Diagram	OBJECT	=E0	DDC	Pg. Cnt.
	MADE	22.09.2006	ARu/Rusanen	JNSY H2390-3, H2403-6		Lngr Ident.	7324-7338	SHEET 19	OF SHEETS 31
	CHKD.	22.09.2006	ARu/Rusanen	M/E		PROJECT #	-	A3-DRAWING #	REV.
	APPVD.	22.09.2006	RTu/Tuominen				407439		A

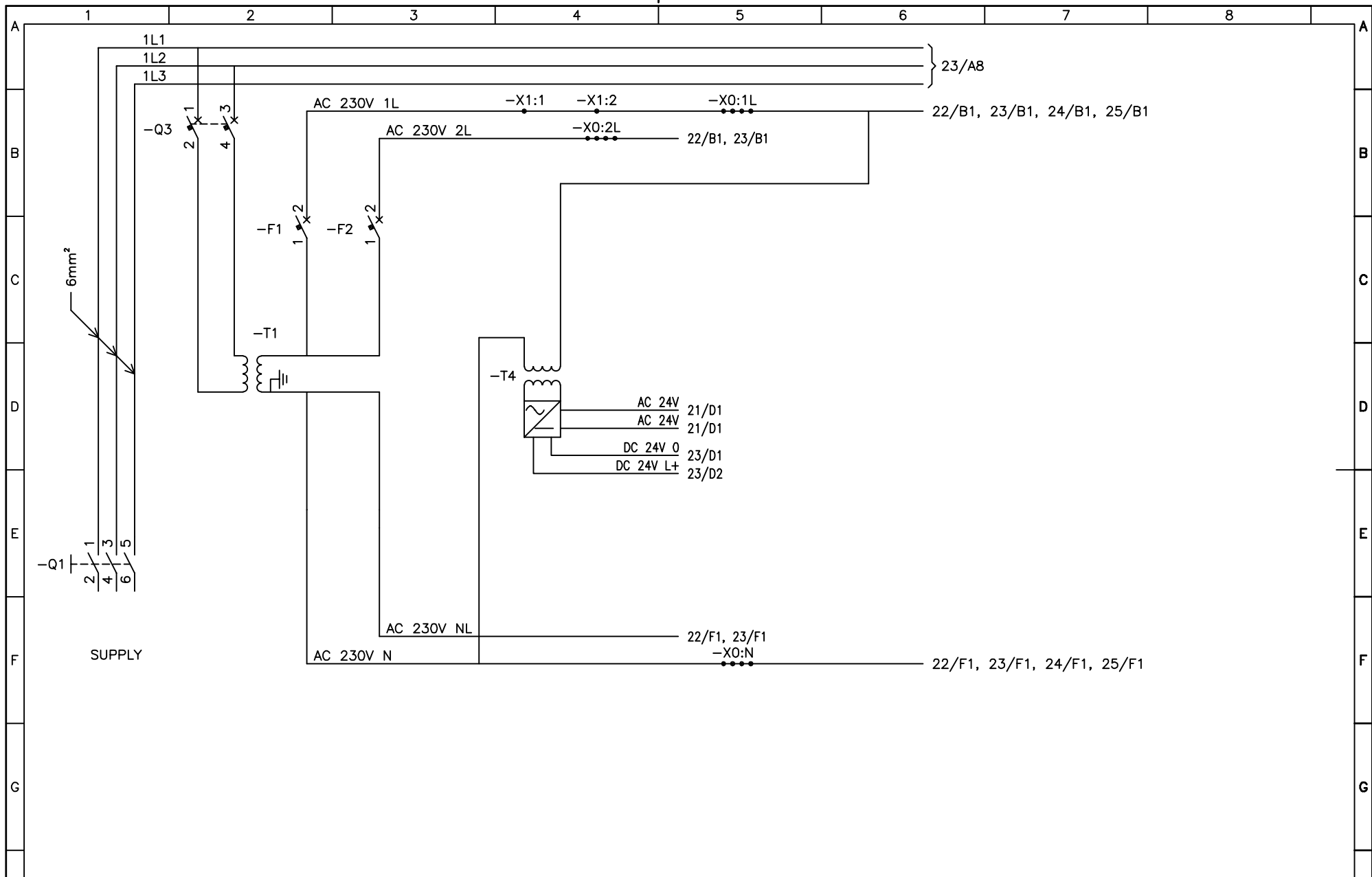

 AURAMARINE Ltd FINLAND	Product	AMB-M	SCALE	HUA HAI EQUIPMENT & ENG.	BOOSTER UNIT CONTROL PANEL SUPPLY Circuit Diagram	OBJECT	=E0-A0	DDC	Pg. Cnt.	
	MADE	22.09.2006	ARu/Rusanen	JNSY H2390-3, H2403-6		Lng	GB	Suppl. 7324-7338	SHEET 20	OF SHEETS 31
	CHKD.	22.09.2006	ARu/Rusanen	M/E		PROJECT #	-	A3-DRAWING #	407439	REV.
	APPVD.	22.09.2006	RTu/Tuominen							A

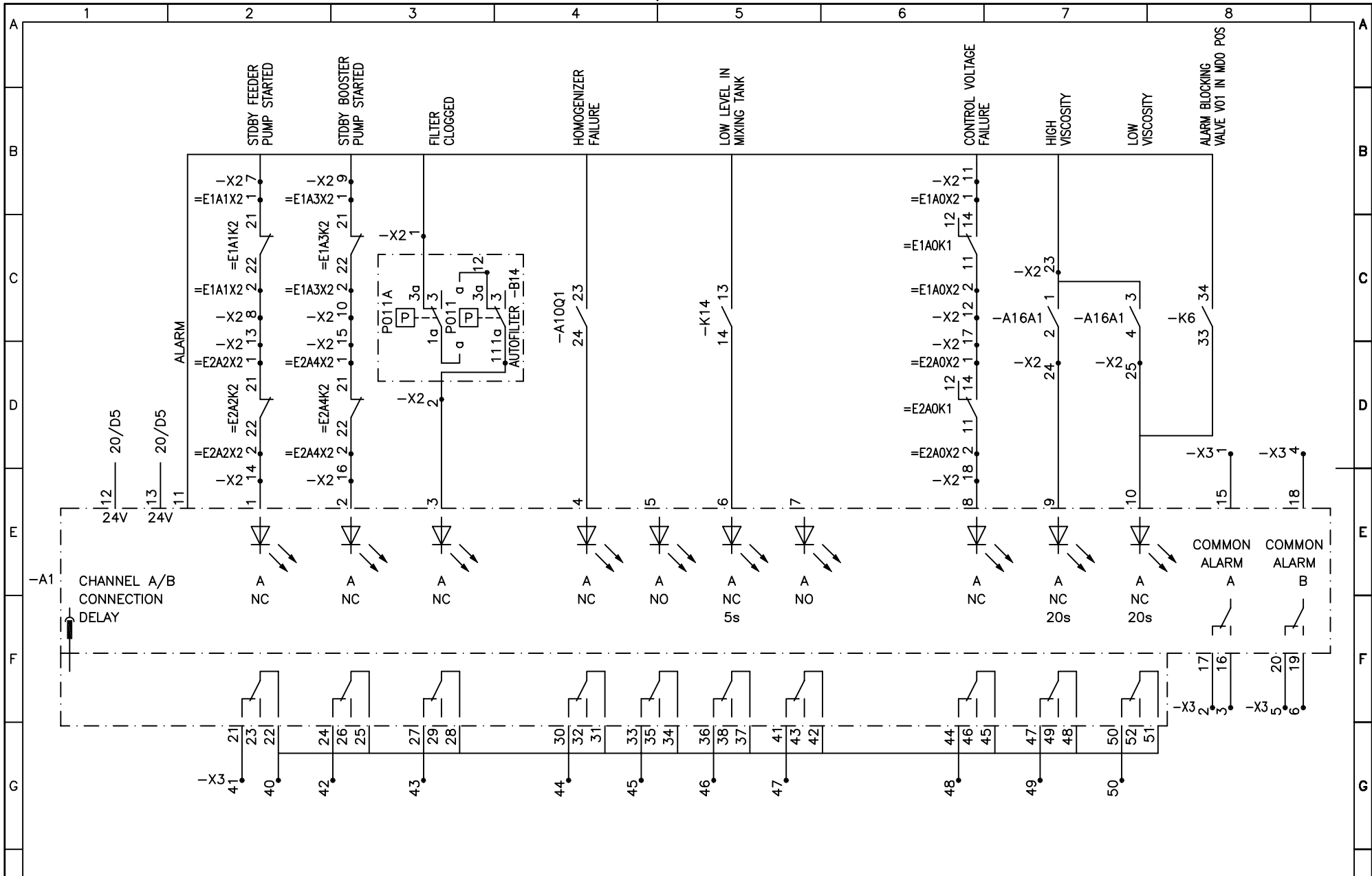

 AURAMARINE Ltd FINLAND	Product	AMB-M	CAD SCALE	HUA HAI EQUIPMENT & ENG. JNSY H2390-3, H2403-6 M/E	BOOSTER UNIT CONTROL PANEL ALARMS Circuit Diagram	OBJECT	=E0-A0	DDC	Pg. number	21 OF 31 SHEETS 31		
	MADE	22.09.2006	ARu/Rusanen			Lang	GB	Suppl.	7324-7338		SHEET	
	CHKD.	22.09.2006	ARu/Rusanen			PROJECT #						REV.
	APPVD.	22.09.2006	RTu/Tuominen									

F1

M1

F1

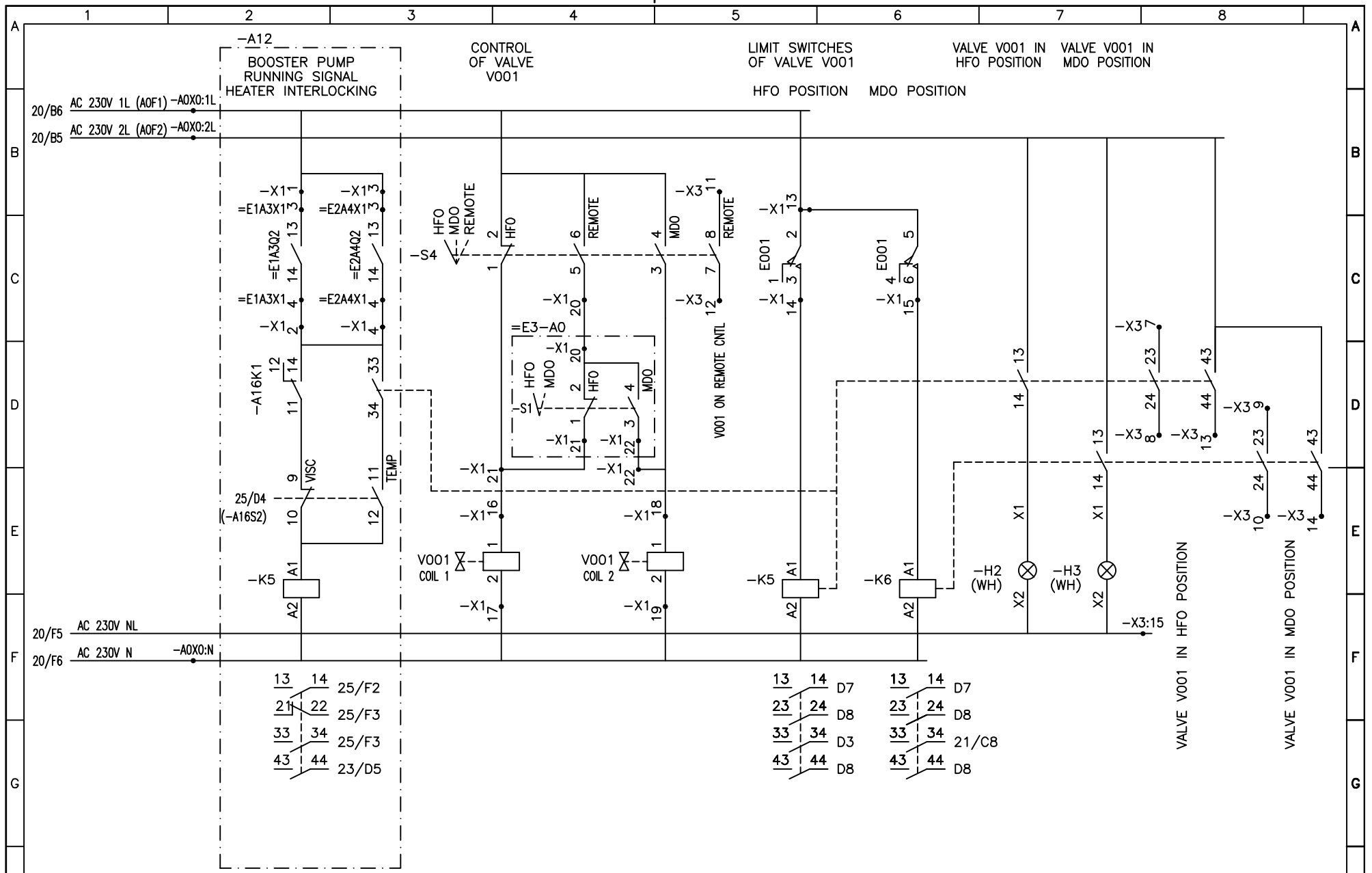

<p>AURAMARINE AURAMARINE Ltd FINLAND</p>	Product	AMB-M	CAD SCALE	HUA HAI EQUIPMENT & ENG.	BOOSTER UNIT CONTROL PANEL	OBJECT	=E0-A0,A12	DDC	Pg. Cnt.	number
	MADE	22.09.2006	ARu/Rusanen	JNSY H2390-3, H2403-6	HEATER INTERLOCKINGS, VALVE V001, SIGNALS	Lng	GB	Suppl.	7324-7338	SHEET 22
	CHKD.	22.09.2006	ARu/Rusanen	M/E	Circuit Diagram	PROJECT #		A3-DRAWING #		REV.
	APPVD.	22.09.2006	RTu/Tuominen				407439			A

a Flow meter changed 4.1.2007 ARu

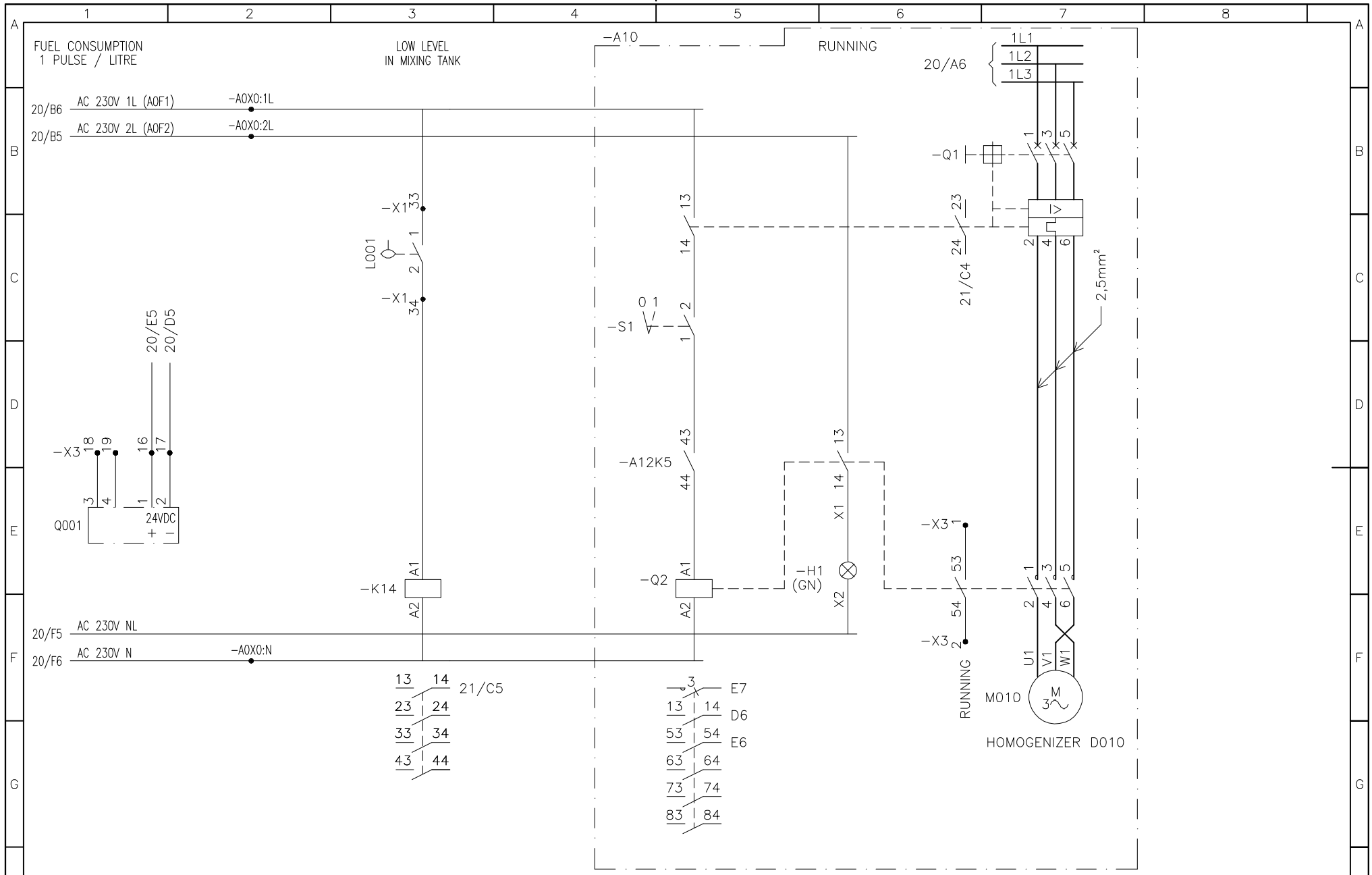

AURA MARINE
AURAMARINE Ltd
FINLAND

Product	AMB-M	CAD	SCALE
MADE	22.09.2006	ARu/Rusanen	
CHKD.	22.09.2006	ARu/Rusanen	
APPVD.	22.09.2006	RTu/Tuominen	

HUA HAI EQUIPMENT & ENG.
JNSY H2390-3, H2403-6
M/E

BOOSTER UNIT CONTROL PANEL
SIGNALS, ALARMS, HOMOGENIZER
Circuit Diagram

OBJECT	=E0-A0,A10	DDC	Pg. Cnt. number
LngGB Ident.	7324-7338	SHEET 23	OF SHEETS 31
PROJECT #	A3-DRAWING #	REV.	
	407439	A	

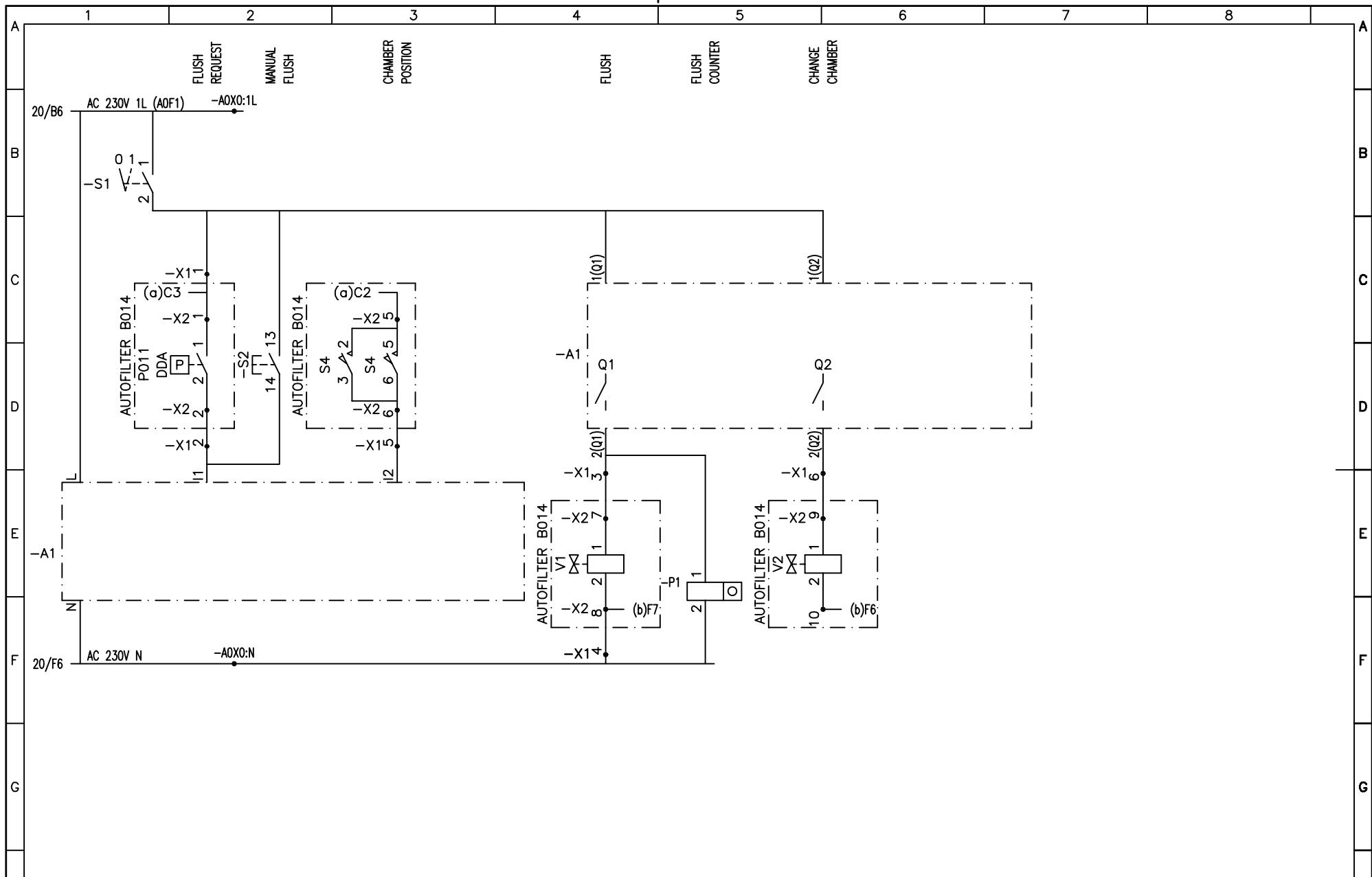

 AURAMARINE Ltd FINLAND	Product	AMB-M	CAD	SCALE	HUA HAI EQUIPMENT & ENG. JNSY H2390-3, H2403-6 M/E	BOOSTER UNIT CONTROL PANEL AUTO FILTER Circuit Diagram	OBJECT	=E0-A14	DDC	Pg	Cnt.			
	MADE	22.09.2006	ARu/Rusanen				Ln	Suppl.	7324-7338	SHEET	24	OF	SHEETS	31
	CHKD.	22.09.2006	ARu/Rusanen				PROJ	#	A3-DRAWING	#	REV.			
	APPVD.	22.09.2006	RTu/Tuominen						407439		A			

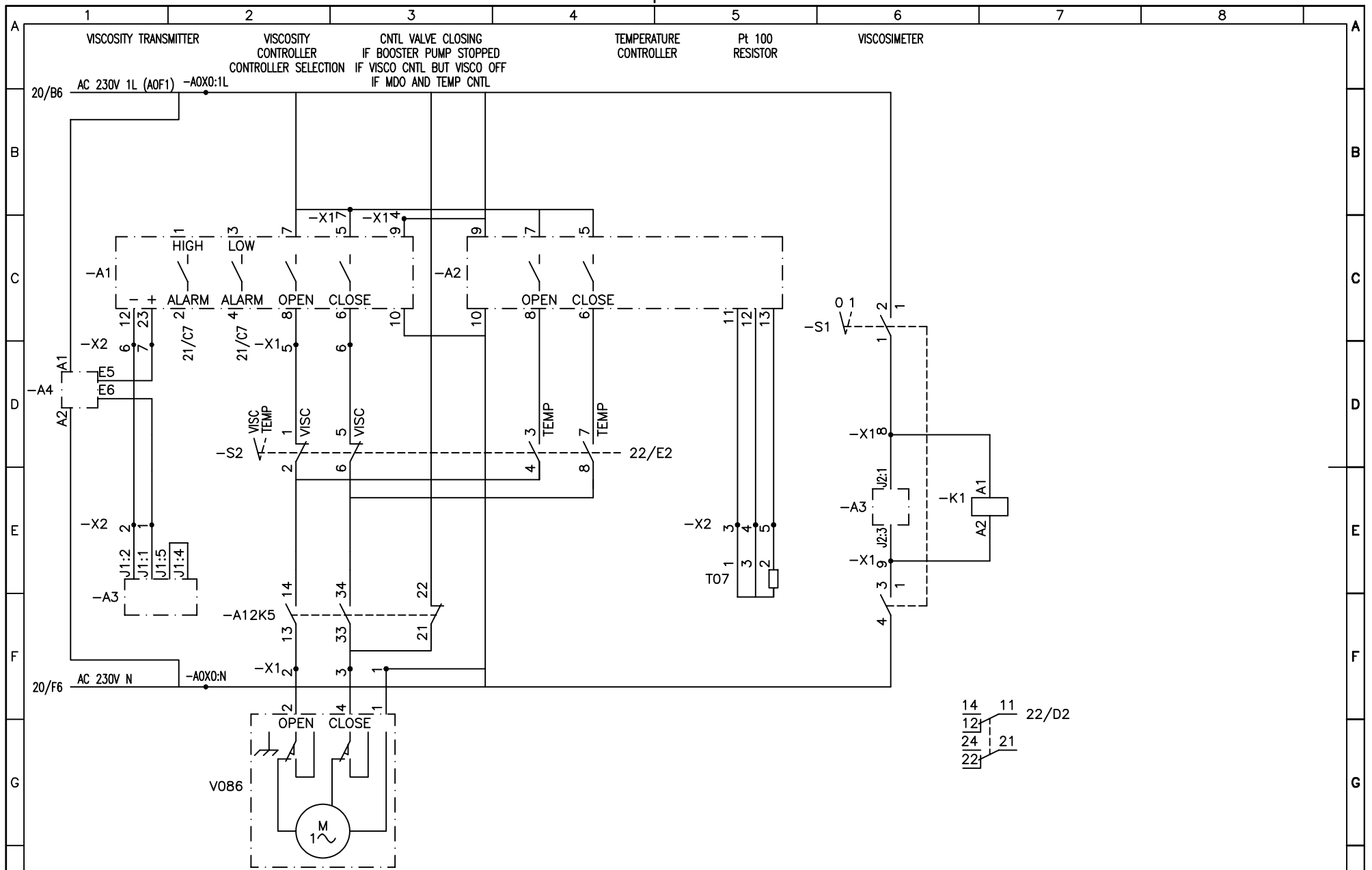

Product	AMB-M	CAD/SCALE	ARu/Rusanen
MADE	22.09.2006	ARu/Rusanen	
CHKD.	22.09.2006	ARu/Rusanen	
APPVD.	22.09.2006	RTu/Tuominen	

HUA HAI EQUIPMENT & ENG.
JNSY H2390-3, H2403-6
M/E

BOOSTER UNIT CONTROL PANEL
VISCOSIMETER, VISC CONTROL
Circuit Diagram

OBJECT	=E0-A16	DDC	Pg. Cnt. number
Lang	GB	Suppl. 7324-7338	SHEET 25 OF SHEETS 31
PROJECT #	A3-DRAWING #	REV.	
-	407439	A	

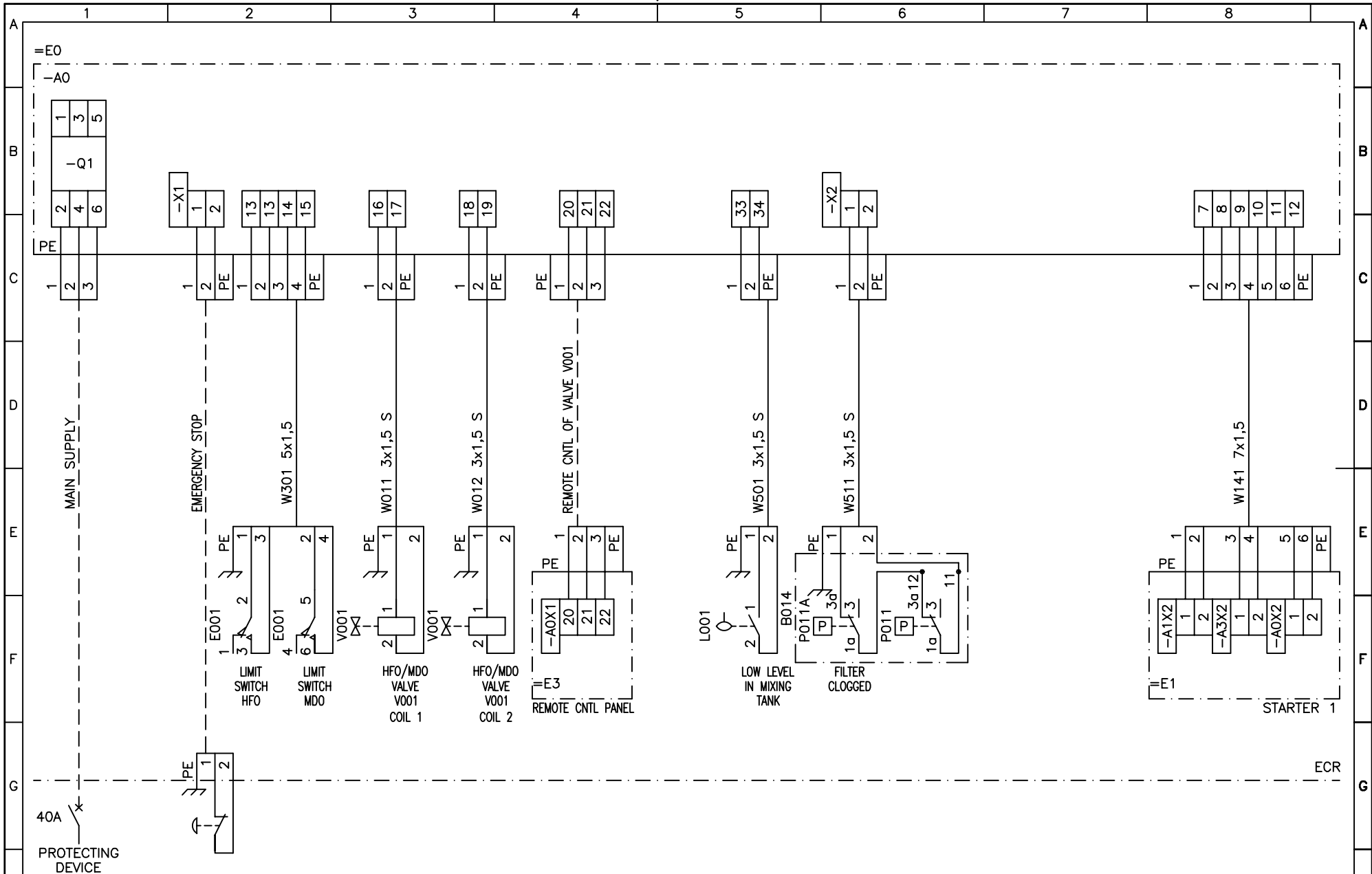

Product	AMB-M	CAD SCALE	
MADE	22.09.2006	ARu/Rusanen	
CHKD.	22.09.2006	ARu/Rusanen	
APPVD.	22.09.2006	RTu/Tuominen	

HUA HAI EQUIPMENT & ENG.
JNSY H2390-3, H2403-6
M/E

BOOSTER UNIT CONTROL PANEL
SUPPLY, ALARMS
Interconnection Diagram

OBJECT	=E0 DDC	Pg. Cnt.	number
Lang	GB	Suppl. Ident.	7324-7338
PROJECT #	-	SHEET	26 OF 31
		DRAWING #	407439
		REV.	A

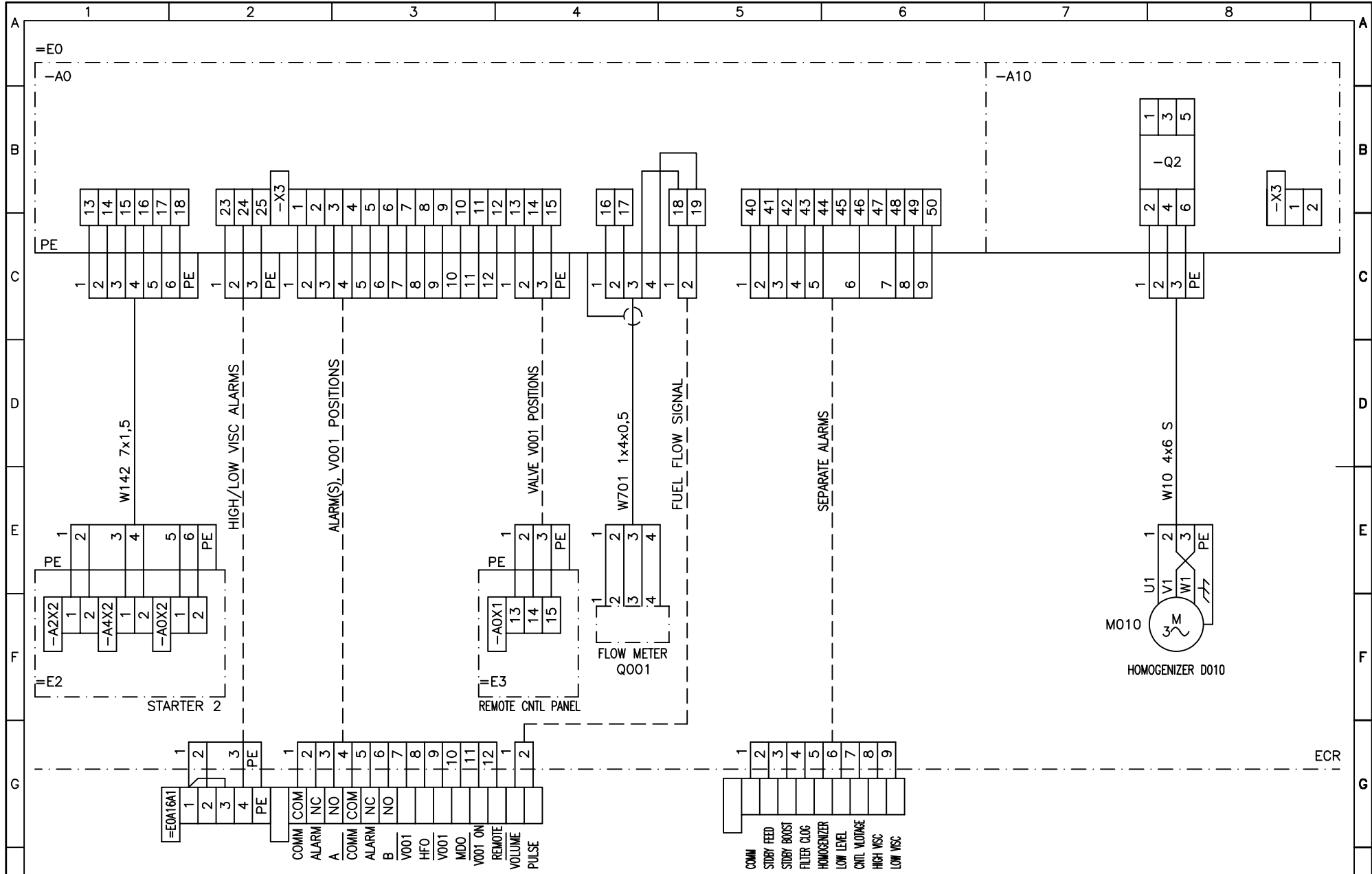

<p>AURAMARINE AURAMARINE Ltd FINLAND</p>	Product	AMB-M	CAD SCALE	HUA HAI EQUIPMENT & ENG.	BOOSTER UNIT CONTROL PANEL ALARMS, SIGNALS, HOMOGENIZER Interconnection Diagram	OBJECT	=E0 DDC	Pg. Cnt.		
	MADE	22.09.2006	ARu/Rusanen	JNSY H2390-3, H2403-6		Lng	GB	Suppl. 7324-7338	SHEET 27	OF SHEETS 31
	CHKD.	22.09.2006	ARu/Rusanen	M/E		PROJECT #		A3-DRAWING #		REV.
	APPVD.	22.09.2006	RTu/Tuominen					407439		A

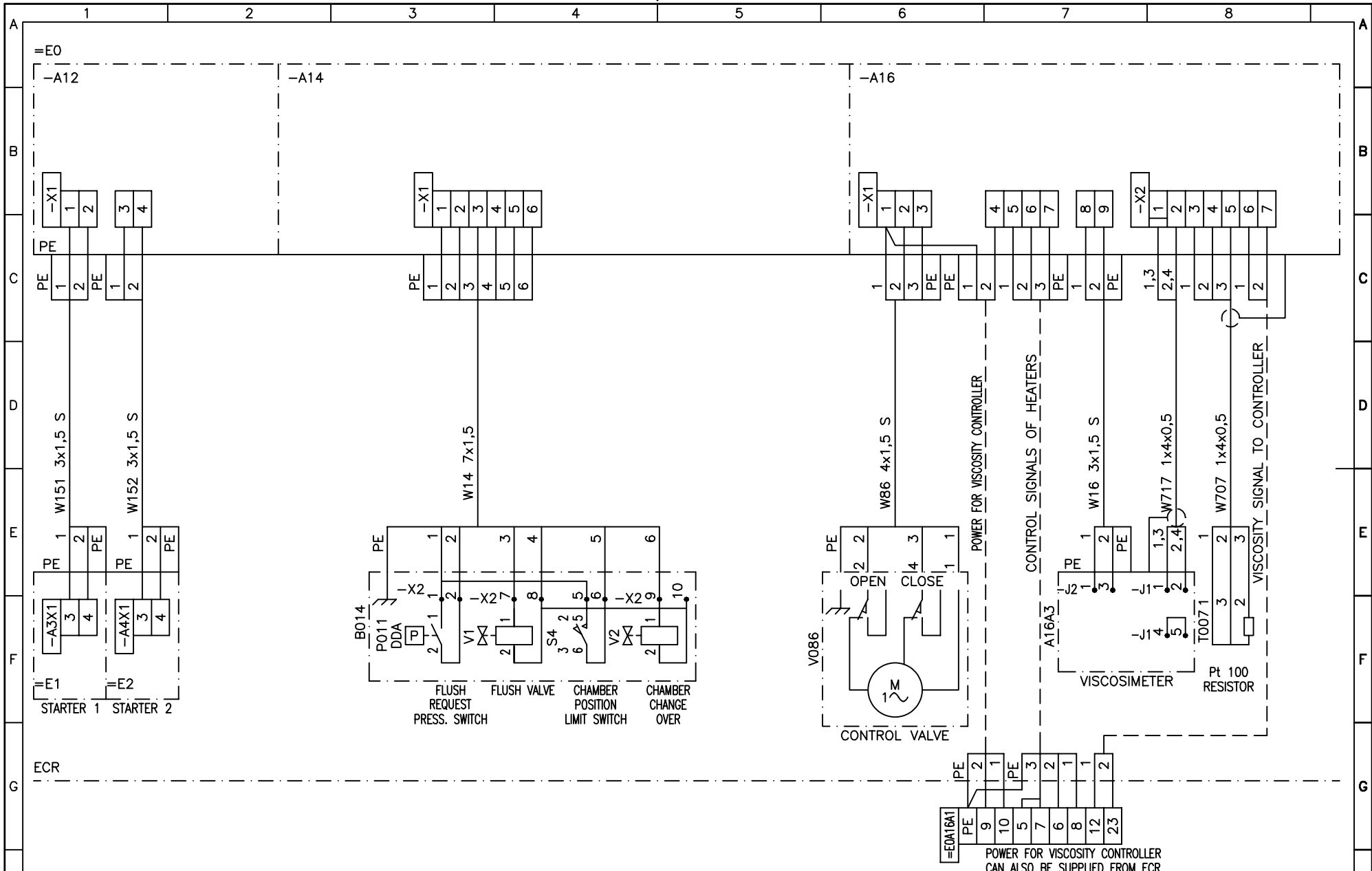

Product	AMB-M	CAD	SCALE
MADE	22.09.2006	ARu/Rusanen	
CHKD.	22.09.2006	ARu/Rusanen	
APPVD.	22.09.2006	RTu/Tuominen	

HUA HAI EQUIPMENT & ENG.
 JNSY H2390-3, H2403-6
 M/E

BOOSTER UNIT CONTROL PANEL
 AUTOMATIC FILTER & VISCOSIMETER
 Interconnection Diagram

OBJECT	=E0 DDC	Pg. Cnt.	number
Lang	GB	Suppl.	7324-7338
PROJECT #	A3-DRAWING #	SHEET	28 OF 31
	407439	REV.	A

SHEET STEEL
SCANTLING 3mm
COLOR RAL 7035

LABELS FASTENED
ONLY WITH STICKERS
NO POP-RIVETS

LIST OF LABELS

id	pcs	text
1	1	M/E C-0 VALVE
-	-	CONTROL PANEL
AOS1	1	HFO/MDO VALVE V001
-	-	HFO MDO
AOH2	1	VALVE V001 IN
-	-	HFO POSITION
AOH3	1	VALVE V001 IN
-	-	MDO POSITION

FRONT VIEW

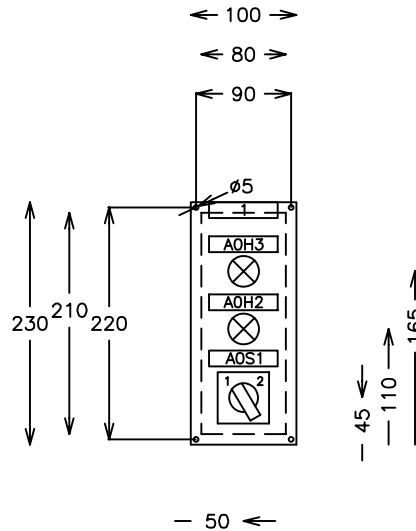

SIDE VIEW OF BACKSIDE

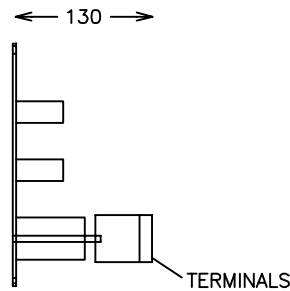

AC 230V 60Hz





Product	AMB-M	CAD	SCALE
MADE	22.09.2006	ARu/Rusanen	
CHKD.	22.09.2006	ARu/Rusanen	
APPVD.	22.09.2006	RTu/Tuominen	

HUA HAI EQUIPMENT & ENG.
JNSY H2390-3, H2403-6
M/E

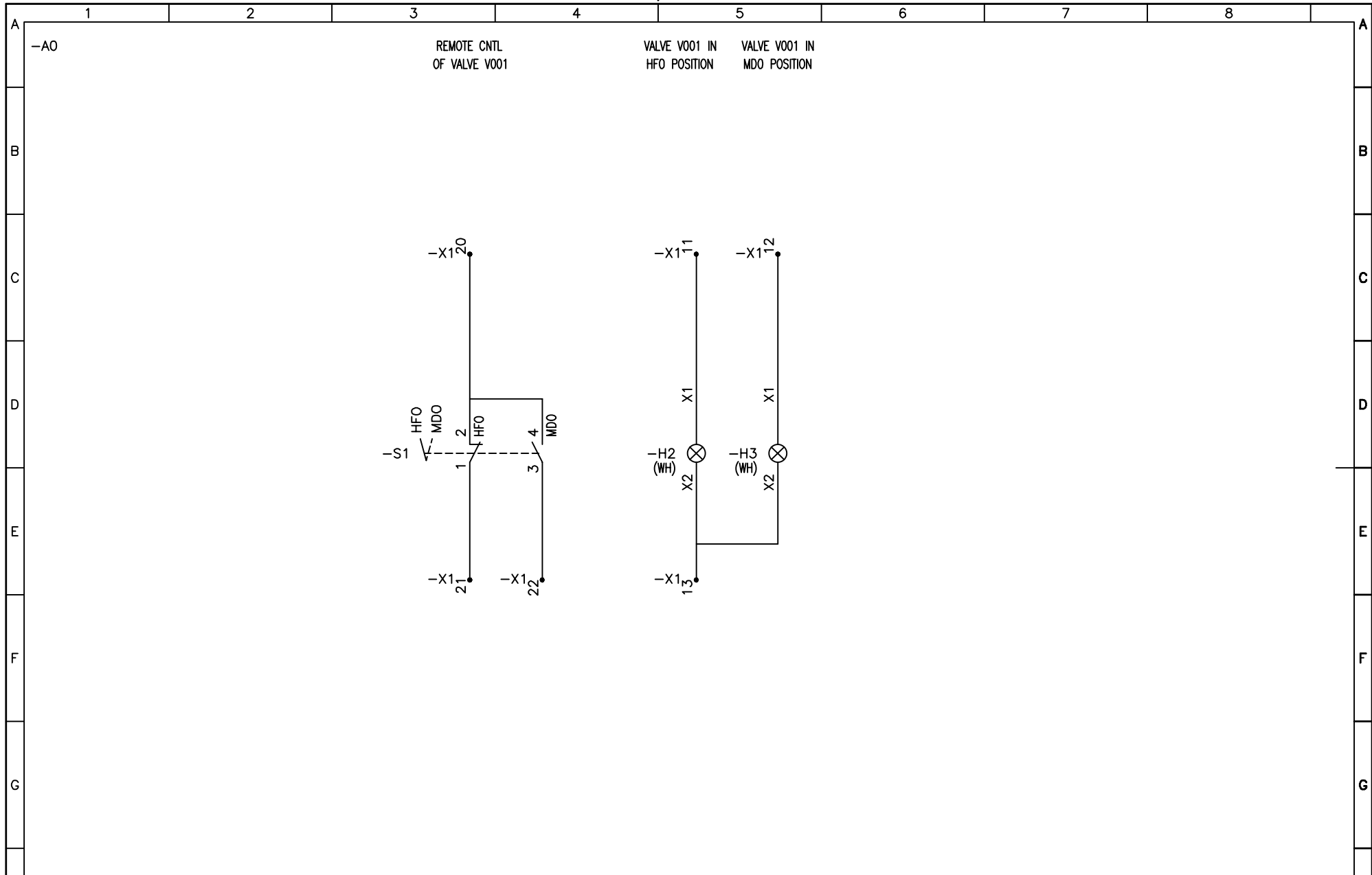

BOOSTER UNIT REMOTE CNTL PANEL
-
Assembly Drawing

OBJECT	=E3DDC	Pg. Cnt.	number
Lang	GB	Suppl.	7324-7338
PROJECT #	-	A3-DRAWING #	407439
		SHEET	29
		REV.	A
		OF SHEETS	31

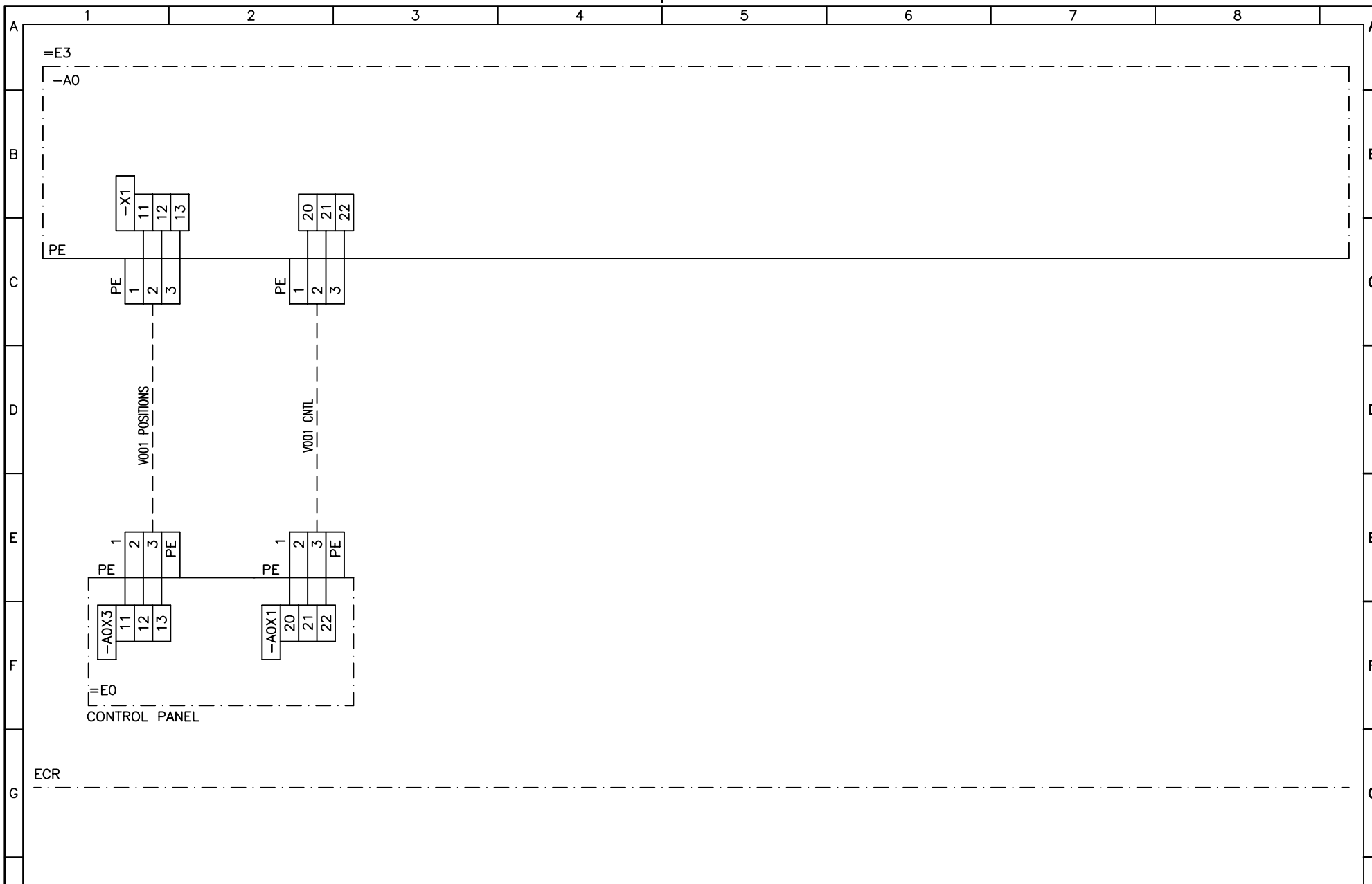

 AURAMARINE Ltd FINLAND	Product	AMB-M	CAD SCALE	HUA HAI EQUIPMENT & ENG. JNSY H2390-3, H2403-6 M/E	BOOSTER UNIT REMOTE CNTL PANEL V001 CONTROL Circuit Diagram	OBJECT	=E3-A0	DDC	Pg. number		
	MADE	22.09.2006	ARu/Rusanen			Lngr Ident.	7324-7338	SHEET 30	OF SHEETS 31		
	CHKD.	22.09.2006	ARu/Rusanen			PROJECT #	-	A3-DRAWING #	407439	REV.	A
	APPVD.	22.09.2006	RTu/Tuominen								



 AURAMARINE AURAMARINE Ltd FINLAND	Product	AMB-M	 SCALE	HUA HAI EQUIPMENT & ENG.	BOOSTER UNIT REMOTE CNTL PANEL	OBJECT	=E3	Pg. Cnt.	DDC	number
	MADE	22.09.2006	ARu/Rusanen	JNSY H2390-3, H2403-6	V001 CONTROL	Lng	GB	Suppl.	7324-7338	SHEET 31
	CHKD.	22.09.2006	ARu/Rusanen	M/E	Interconnection Diagram	PROJECT #	-	A3-DRAWING #	407439	REV.
	APPVD.	22.09.2006	RTu/Tuominen							A

F1

M1

F1

ITEM	QTY	PART NO	DESCRIPTION	TYPE	MAKE	SETTING RANGE	RATED CURRENT
STARTER 1	1	AF00509	Compact enclosure	AE 1039.500	Rittal		
	1	AF00534	Door stay for the AE range	SZ 2519.000	Rittal		
	0,04	AF00558	Adhesive backed foam tape	VCI-170 6,1mx(51x6,3mm)	Cortec		
A0Q1	1	AF00733	Switch disconnecter	OT 63 E3	ABB		
A0Q1	1	AF00740	Handle	OHY 2 AJ	ABB		
A0Q1	1	AF00735	Shaft	OXS5x160	ABB		
A0Q3	1	AF00340	Miniature circuit-breaker	5SX2 202-8	Siemens		2 A
A0T1	1	AF00632	Transformer	PE 250 VA	Trafomic		
A0F1,A0F2	2	AF00328	Miniature circuit-breaker	5SX2 102-7	Siemens		2 A
A0K1	1	AF00501	Time relay	MBS 2.430.012.02	Schiele		
A1Q1	1	AF00367	Auxiliary contact	140-A11	Allen-Bradley		
A1Q1	1	AF00359	Circuit breaker	140-MN-1000	Allen-Bradley	6,3...10,0 A	
A1Q2	1	AF00476	Contactactor	100-C12KF10	Allen-Bradley		
A1Q2	1	AF00487	Auxiliary contact block	100-FA31	Allen-Bradley		
A1K1	1	AF00501	Time relay	MBS 2.430.012.02	Schiele		
A1S1	1	AF00714	Rotary cam switch	WAJ 545/8ZM/NS/AURA	Sontheimer		
A1K2	1	AF00443	Control relay	700-CF220KF	Allen-Bradley		
A1H1	1	AF00883	Indicating light	CL-523G	ABB		
A1H2	1	AF00882	Indicating light	CL-523R	ABB		
A1P1	1	AF00596	Self-powered time counter	H7ET-NFV-B	Omron Electronics		
A3Q1	1	AF00367	Auxiliary contact	140-A11	Allen-Bradley		
A3Q1	1	AF00362	Circuit breaker	140-MN-2500	Allen-Bradley	20...25 A	
A3Q2	1	AF00479	Contactactor	100-C30KF10	Allen-Bradley		
A3Q2	1	AF00487	Auxiliary contact block	100-FA31	Allen-Bradley		
A3S1	1	AF00714	Rotary cam switch	WAJ 545/8ZM/NS/AURA	Sontheimer		
A3K2	1	AF00443	Control relay	700-CF220KF	Allen-Bradley		
A3H1	1	AF00883	Indicating light	CL-523G	ABB		
A3H2	1	AF00882	Indicating light	CL-523R	ABB		
A3P1	1	AF00596	Self-powered time counter	H7ET-NFV-B	Omron Electronics		
STARTER 2	1	AF00509	Compact enclosure	AE 1039.500	Rittal		
	1	AF00534	Door stay for the AE range	SZ 2519.000	Rittal		
	0,04	AF00558	Adhesive backed foam tape	VCI-170 6,1mx(51x6,3mm)	Cortec		
A0Q1	1	AF00733	Switch disconnecter	OT 63 E3	ABB		
A0Q1	1	AF00740	Handle	OHY 2 AJ	ABB		
A0Q1	1	AF00735	Shaft	OXS5x160	ABB		

Auramarine Ltd
Finland

EL. PART LIST

Product: AMB-M
Made: 21.08.2007 ARu/Rusanen
Chkd: 21.08.2007 ARu/Rusanen
Appvd: 21.08.2007 RTu/Tuominen

Product id: 7324-7338
Document id: PL407439B
Sheet 1 of 3

ITEM	QTY	PART NO	DESCRIPTION	TYPE	MAKE	SETTING RANGE	RATED CURRENT
A0Q3	1	AF00340	Miniature circuit-breaker	5SX2 202-8	Siemens		2 A
A0T1	1	AF00632	Transformer	PE 250 VA	Trafomic		
A0F1,A0F2	2	AF00328	Miniature circuit-breaker	5SX2 102-7	Siemens		2 A
A0K1	1	AF00501	Time relay	MBS 2.430.012.02	Schiele		
A2Q1	1	AF00367	Auxiliary contact	140-A11	Allen-Bradley		
A2Q1	1	AF00359	Circuit breaker	140-MN-1000	Allen-Bradley	6,3...10,0 A	
A2Q2	1	AF00476	Contacto	100-C12KF10	Allen-Bradley		
A2Q2	1	AF00487	Auxiliary contact block	100-FA31	Allen-Bradley		
A2S1	1	AF00714	Rotary cam switch	WAJ 545/8ZM/NS/AURA	Sontheimer		
A2K2	1	AF00443	Control relay	700-CF220KF	Allen-Bradley		
A2H1	1	AF00883	Indicating light	CL-523G	ABB		
A2H2	1	AF00882	Indicating light	CL-523R	ABB		
A2P1,A4P1	2	AF00596	Self-powered time counter	H7ET-NFV-B	Omron Electronics		
A4Q1	1	AF00367	Auxiliary contact	140-A11	Allen-Bradley		
A4Q1	1	AF00362	Circuit breaker	140-MN-2500	Allen-Bradley	20...25 A	
A4Q2	1	AF00479	Contacto	100-C30KF10	Allen-Bradley		
A4Q2	1	AF00487	Auxiliary contact block	100-FA31	Allen-Bradley		
A4K1	1	AF00501	Time relay	MBS 2.430.012.02	Schiele		
A4S1	1	AF00714	Rotary cam switch	WAJ 545/8ZM/NS/AURA	Sontheimer		
A4K2	1	AF00443	Control relay	700-CF220KF	Allen-Bradley		
A4H1	1	AF00883	Indicating light	CL-523G	ABB		
A4H2	1	AF00882	Indicating light	CL-523R	ABB		
CNTL PANEL	1	AF00514	Compact enclosure	AE 1077.500	Rittal		
	1	AF00534	Door stay for the AE range	SZ 2519.000	Rittal		
	0,11	AF00558	Adhesive backed foam tape	VCI-170 6,1mx(51x6,3mm)	Cortec		
A0Q1	1	AF00732	Switch disconnecto	OT 45 E3	ABB		
A0Q1	1	AF00740	Handle	OHY 2 AJ	ABB		
A0Q1	1	AF00735	Shaft	OXS5x160	ABB		
A0Q3	1	AF00340	Miniature circuit-breaker	5SX2 202-8	Siemens		2 A
A0T1	1	AF00633	Transformer	PE 400 VA	Trafomic		
A0F1,A0F2	2	AF00328	Miniature circuit-breaker	5SX2 102-7	Siemens		2 A
A0T4	1	AF00644	1-Phase power supply	TC 115+115/24AC,24DC, 0,35/0,096A	Trafomic		
AOA1	1	AF00005	Alarm display unit	LLC-10, 24 V AC	IMSAB Ingenjörsfirman M Sjöbris AB		
AOA1	1	AF00007	Relay circuit board	LLC RF	IMSAB Ingenjörsfirman M Sjöbris AB		
A0K14	1	AF00441	Control relay	700-CF400KF	Allen-Bradley		

Auramarine Ltd
Finland

EL. PART LIST

Product: AMB-M
Made: 21.08.2007 ARu/Rusanen
Chkd: 21.08.2007 ARu/Rusanen
Appvd: 21.08.2007 RTu/Tuominen

Product id: 7324-7338
Document id: PL407439B
Sheet 2 of 3

ITEM	QTY	PART NO	DESCRIPTION	TYPE	MAKE	SETTING RANGE	RATED CURRENT
A0K5,A0K6	2	AF00441	Control relay	700-CF400KF	Allen-Bradley		
A0H2,A0H3	2	AF00880	Indicating light	CL-523W	ABB		
A0S4	1	AF00762	Rotary cam switch	ST34/8ZM/F302/NS/AURA	Sontheimer		
A10Q1	1	AF00366	Auxiliary contact	140-A20	Allen-Bradley		
A10Q1	1	AF00362	Circuit breaker	140-MN-2500	Allen-Bradley	20...25 A	
A10Q2	1	AF00479	Contacto	100-C30KF10	Allen-Bradley		
A10Q2	1	AF00486	Auxiliary contact block	100-FA40	Allen-Bradley		
A10S1	1	AF00693	Rotary cam switch	A2/8ZM/F601/AURA	Sontheimer		
A10H1	1	AF00883	Indicating light	CL-523G	ABB		
A14S1	1	AF00693	Rotary cam switch	A2/8ZM/F601/AURA	Sontheimer		
A14S2	1	AF01168	Push-button	MP1-10B	ABB		
A14S2	1	AF01189	1NO contact	MCB-10	ABB		
A14S2	1	AF01193	Contact holder for 3 contacts	MCBH-00	ABB		
A14P1	1	AF00597	Self-powered total counter	H7EC-NFV-B, 230V	Omron Electronics		
A14A1	1	AF00689	Logic module LOGO! 230 RC	6ED1052-1FB00-0BA5	Siemens		
LOOSE_A16A1	1	AF00679	Digital controller	E5EK-PRR2-500 AC100-240 (4-20 mA)	Omron Electronics		
A16A2	1	AF00681	Digital controller	E5EK-PRR2-500 AC100-240 (PT-100 fee	Omron Electronics		
A16S2	1	AF00709	Rotary cam switch	WS4/8ZM/F614/AURA	Sontheimer		
A16S1	1	AF00693	Rotary cam switch	A2/8ZM/F601/AURA	Sontheimer		
A16K1	1	AF00428	Miniature relay	40.52.8.230	Finder		
A16K1	1	AF00429	Screw terminal socket	95,75	Finder		
A12K5	1	AF00442	Control relay	700-CF310KF	Allen-Bradley		
A16A4	1	AF00599	Prosess meter	K3MA-J-A2 100-240 VAC	Omron Electronics		
REMOTE CNTL PANEL							
A0S1	1	AF00708	Rotary cam switch	WS2/8ZM/F614/AURA	Sontheimer		
A0H2,A0H3	2	AF00880	Indicating light	CL-523W	ABB		

EL. PART LIST



SECTION 4

4 Factory certificate

MAKER'S CERTIFICATE

This is to certify that AURAMARINE ASIA LD did inspection and test of:

Unit type: AMB-M-50-SS
Site: Auramarine Shanghai
Classification Society: GL

DRAWINGS

General arrangement: 407432
P&I diagram: 306574
Electric diagram: 407439A

VOLTAGE: 440V/60HZ/230VAC

PRESSURE TEST	DP bar	WP bar	TP bar	MEDIUM
Suction side	2	0	N/A	Oil
Feeder side	6	4	10	Oil
De-aeration vessel	6	4	10	Oil
Booster side	12	4-10	18	Oil
Steam side	10	7	15	AIR/Water

The unit is surveyed in finished condition and tested min. 1.5xDP and found tight and in satisfactory condition.

GENERAL INSPECTION: The installation of mechanical/electrical equipment was considered satisfactory.

THE UNIT IS FINALLY STAMPED: "TP 15 bar"

Place: Shanghai, PRC

Tester:



Gu Cheng/AURAMARINE ASIA LTD

Date: 2008.02.19

AURAMARINE ASIA LTD.

Add: No. 13 LongYang Industrial Zone, No. 888
XinFeng Road, FengXian District, 201401 Shanghai, PRC
Tel: +86-21-6710 4305
FAX: +86-21-6710 4306

奥拉莫林(上海)船用设备有限公司
地址: 上海莘奉公路 888 号龙洋工业园区 13 号厂房
邮编: 201401
电话: +86-21-6710 4305
传真: +86-21-6710 4306

TEST REPORT

Manufacturer: AURAMARINE ASIA LTD

Tested and approved by: GU CHENG

Date: 2008.10.21

FUNCTIONAL TEST RESULT AND SET POINTS

Oil type: Fuchs Anticorit 5F

Pressure test:

Feeder side: 10 bars
Booster side: 18 bars
Steam side: 15 bars

DENOMINATION	FUNCT ION	SETTING RANGE	SET POINT
1.INSPECTION OF COMPONENT SUPPORT	Ok		
2.FEEDER PUMPS	Ok		
Motor protection		4.0-6.3A	4.75A
Stand-by press. Switch setting	Ok	1-10bar	3bar
Safety valves inside the pumps			10bar
3.PRESSURE CONTROL OVERFLOW VALVE		2-5Bar	4bar
4.DEAERATION SYSTEM	Ok		
Pilot air pressure			
Pressure keeping valve			
Low level alarm	Ok		
Safety valve			15bar

DENOMINATION	FUNC TION	SETTIG RANGE	SET POINT
5.BOOSTER PUMPS	Ok		

AURAMARINE ASIA LTD.

Add: No. 13 LongYang Industrial Zone, No. 888
13号厂房

XinFeng Road, FengXian District, 201401 Shanghai, PRC

Tel: +86-21-6710 4305

FAX: +86-21-6710 4306

奥拉莫林(上海)船用设备有限公司

地址: 上海莘奉公路 888 号龙洋工业园区

邮编: 201401

电话: +86-21-6710 4305

传真: +86-21-6710 4306

Motor protection		6.3-10.0A	8.3A
Stand-by press. Switch setting	Ok	1-10bar	6bar
Safety valves inside pumps	Ok		15bar
6.HEATERS SAFETY VALVES			16bar
7.TEMPERATURE CONTROL SYSTEM	Ok	0-200C	135C
Overtemp. alarm			
High temp. alarm			
Low temp. alarm			
Heating control valve	Ok		
Proportional band		0.1-999.9%	2.0%
Integral time		0-3999s	240s
Derivation time			40s
8.VISCOSITY CONTR.SYSTEM	Ok	0-50cSt	13cSt
Motor protection			
Low viscosity	Ok	From set point	-3cSt
High viscosity	Ok	From set point	+3cSt
Heating control valve	Ok		
Air regulating unit (if any)			
Proportional band		0.1-999.9%	10%
Integral time		0-3999s	240s
Derivation time			
9. CONTROL FOR EL.HEATER PRESSURE SWITCHES			
10.AUTOMATIC FILTER	Ok		
Motor protection			
Flushing time		0-10s	5 sec.
Flushing period		0-300min	120min
Diff. press. for flushing	Ok		0.6bar
Diff. press. for alarm	Ok		0.8bar

DENOMINATION	FUNC TION	SETTING RANGE	SET POINT
11.RUNNING LIGHTS	Ok		
12. OUTPUT SIGNAL	Ok		
mars viscosity signal	Ok	4-20mA/0-50cSt	
am/l/h	Ok		
13.ALARMS TO CONTR.ROOM	Ok		

AURAMARINE ASIA LTD.

Add: No. 13 LongYang Industrial Zone, No. 888
13号厂房
XinFeng Road, FengXian District, 201401 Shanghai, PRC
Tel: +86-21-6710 4305
FAX: +86-21-6710 4306

奥拉莫林(上海)船用设备有限公司
地址: 上海莘奉公路 888 号龙洋工业园区
邮编: 201401
电话: +86-21-6710 4305
传真: +86-21-6710 4306

14. OTHER ALARMS		
High difference pressure		
Low pressure alarm		
Low instrument air pressure		
15. CONTINUITY OF PROTECTIVE BONDING CIRCUIT		
16. INSULATION RESISTANCE TEST	Ok	
17. VOLTAGE TEST	Ok	2500V
18. MOTOR & EL. HEATER CURRENTS	Ok	
DO NOT EXCEED NORMAL VALUES	Ok	

Calibrated testing equipments:

- multi meter no: 82870249
- clamp meter: 76952904
- pressure gauges no: No1,2,3,4,5,6,7,8,9,10



Tester signature:

Gu Cheng

Witnessed by classification society:

GL

Date: 2008.02.19

AURAMARINE ASIA LTD.

Add: No. 13 LongYang Industrial Zone, No. 888
 13号厂房
 XinFeng Road, FengXian District, 201401 Shanghai, PRC
 Tel: +86-21-6710 4305
 FAX: +86-21-6710 4306

奥拉莫林(上海)船用设备有限公司

地址: 上海莘奉公路 888 号龙洋工业园区
 邮编: 201401
 电话: +86-21-6710 4305
 传真: +86-21-6710 4306



SECTION 5

5 Flow meter certificate



PRÜFZERTIFIKAT

**Certificate
d'étalonnage**

**Test
Certificate**

Kunde / Client / Customer:

Auftrags-Nr. : 114709

Identifikation / Identification

Protokoll-Nr. : A076144 / 07

Zähler Typ / Type de compteur / Meter

VZF 50 FL 130/25

Zähler Nr. / No. du compteur / Meter No.

4706277

Hersteller / Fabricant / Manufacturer

AQUAMETRO AG, Therwil

Prüfbedingungen / Conditions d'étalonnage / Test Conditions

Prüfstand / Banc d'étalonnage / Test Bench: AROP Prüfmedium / Liquide utilisé / Fluid used: Testoil 5.0 mm²/s t
Prüftemperatur / Température du liquide / Fluid Temperature: 21.67 °C Prüfdruck / Pression / Pressure: 5.08 bar

Prüfergebnis / Résultats des mesures / Test Results

Test	Durchfluß / Débit / Flow rate [l/h]	Durchfluß / Débit / Flow rate [%]	Abweichung / Déviation / Deviation %
1	28298	94	-0.08
2	19715	66	0.18
3	2959	10	0.46
4	793	3	-0.56

Bemerkung / Remarque / Remarks

Datum der Kalibrierung / Date
d'étalonnage / Date of calibration:

11.06.2007

Prüfer / Etalonné par / Tested by:

THE

Leiter Kalibrierstelle / Chef du
laboratoire d'étalonnage / Head of
calibration laboratory

Sichler



SECTION 6

6 Instruction manual

1	STORAGE, HANDLING AND INSTALLATION	5
1.1	Storage.....	5
1.2	Handling.....	5
1.3	Installation	5
2	SAFETY INSTRUCTIONS	7
3	WARNINGS AND INSTRUCTIONS	7
4	START-UP	8
5	SHUTDOWN.....	10
6	TROUBLE SHOOTING.....	11
7	MAIN SWITCH.....	12
8	ELECTRONIC TIMER, CT-S RANGE, TYPE 1SVR6300	13
8.1	Operating controls.....	13
8.2	Electrical diagram.....	14
8.3	Function diagrams.....	15
8.4	Factory settings by Auramarine Ltd.....	17
9	COUNTER, TYPE H7E	18
10	ALARM PANEL.....	20
10.1	Alarm panel for units with LRS classification.....	21
11	VISCOSITY AND TEMPERATURE CONTROLLERS E5EK	22
11.1	Operation	25
11.2	Access to parameters.....	26
11.3	Parameter settings of the viscosity controller A16A1	27
11.4	Parameter settings of the temperature controller A16A2.....	30
12	PROCESS METER K3MA-J	33
12.1	Operation	36
12.1.1	Levels.....	36
12.1.2	Parameters	37
12.2	Troubleshooting.....	41
13	RESISTANCE THERMOMETER, MODELS PT COMPACT AND PT COMPACT PLUS	42
14	PRESSURE SWITCH MBC 5000, 5100	43
15	LEVEL LIMIT SWITCH LIQUIPHANT T FTL20	44
15.1	Instructions.....	44
16	VISCOSITY SENSOR, TYPE VISCOSENSE2	46
16.1	Operation	47
16.1.1	Initial start-up.....	47
16.1.2	Routine start-up.....	48
16.1.3	Shutdown on diesel oil	48
16.1.4	Shutdown on heavy fuel oil	48
16.2	Maintenance.....	48
16.2.1	Routine maintenance	48
16.2.2	Cleaning.....	49
16.2.2.1	Sensor assembly	49
16.3	Electrical connections.....	51
16.4	Trouble shooting and repair	52
16.4.1	Diagnostic information.....	52
16.4.2	General trouble shooting.....	54
16.4.3	PI setting errors (for additional viscosity controller).....	56
16.5	Parts lists.....	57
17	FLOW METER, TYPE VZF.....	58

17.1	Display	59
17.2	Operation	60
17.2.1	Main menu	60
17.2.2	Information menu	62
17.2.3	Parameter menu	64
17.2.3.1	Parameter settings	66
17.2.3.2	Parameterising the display	70
17.2.3.3	Parameterising the flow sensor data	70
17.2.3.4	Parameterising the outputs	71
17.3	Error messages	75
17.4	Maintenance	75
18	HEAT EXCHANGER TYPE MX	76
18.1	General Description	76
18.2	Operation	76
18.2.1	Commissioning	76
18.2.2	Initial start-up	76
18.2.3	Output	76
18.2.4	Conservation during shut down periods	77
18.3	Maintenance and cleaning	77
18.3.1	Regular cleaning periods	77
18.3.2	Cleaning of tubes	77
18.3.3	Heavy contamination	78
18.3.4	Checking the safety valves	78
18.3.5	Dismantling and reassembling of the tube section	78
18.4	Spare parts	79
19	ELECTRIC MOTOR, TYPES 7A*, 7B*, 14BG*	80
19.1	General information	80
19.2	Operation and maintenance	81
19.2.1	Lubrication	82
19.3	Electrical connection	83
19.4	Spare parts	84
20	ACG SCREW PUMP	86
20.1	Start-up of ACE and ACG pumps	88
20.1.1	Before starting	88
20.1.1.1	Direction of rotation	89
20.1.2	Starting ACE and ACG pumps	89
20.1.2.1	Setting the pressure relief valve	90
20.1.2.2	Adjusting the tuning	90
20.2	Maintenance	91
20.2.1	Inspection of shaft seal	92
20.2.2	Shaft seal - assembly drawing	92
20.2.3	Service for ball bearing	93
20.2.4	Lubricating intervals in working hours	94
20.2.5	Inspection of rotors	95
20.2.6	Dismantling	96
20.2.7	Re-assembly	100
20.3	Pressure relief valve	104
20.3.1	Replacement of O-ring 605:	104
20.3.2	Replacement of Valve Element G070:	104
20.4	Trouble shooting	105
20.5	List of components	107

20.5.1	Spare part sets.....	108
21	HOMOGENIZER, TYPE LEMAG SLASHPOL H	109
21.1	Start-up	109
21.2	Operation	109
21.3	Maintenance.....	110
21.4	Spare parts.....	111
22	PRESSURE LIMITING VALVE SPVF.....	115
22.1	Description of operation	116
22.2	Constructions and spares.....	116
22.3	Adjustment	117
22.4	Venting	117
23	BALL VALVES, TYPES N2, N8 AND N9	118
23.1	Operation	118
23.1.1	Manual operation	118
23.1.2	Automated operation.....	118
23.2	Maintenance.....	118
23.2.1	Steam leakage	119
23.2.2	Body seals leakage	119
23.2.3	In line or seats leakage	119
23.3	Valve disassembly to inspect and/or replace body seals, seats, packing and ball.....	119
23.4	Inspection and replacement	120
23.5	Re-assembly	120
23.5.1	Steam re-assembly	120
23.5.2	Ball, seats and seals re-assembly, types N8 and N9	120
23.5.3	Ball, seats and seals re-assembly, type N2	121
23.6	Testing	121
23.7	Automated ball valves	121
23.8	Tightness values for handle nut 2A-2B and body bolts 16, types N8 and N9.....	122
23.9	Tightness values for handle nut 2A-2B and body bolts 16, type N2	122
23.10	Storage	122
23.11	Spare parts	123
24	VALVE, SERIES 776000	124
25	SWITCHBOX, SERIES W AUTOMAX	125
25.1	Adjusting limit switches	125
26	CONTROL VALVE, TYPES BR440-446	127
26.1	Maintenance.....	127
26.1.1	Packings with PTFE V-ring unit.....	128
26.1.2	Stuffing box packings	129
26.1.3	Bellow Seal	130
26.1.4	Replacing the Plug, Spindle and Seating	131
26.2	Troubleshooting.....	133
27	THRUST ACTUATOR, TYPE PREMIO	134
27.1	Manual operation.....	135
27.1.1	2.2 - 5 Kn	135
27.1.2	12 - 15 Kn	136
27.2	Settings	137
27.2.1	Torque and travel switches -standard feature	137
27.2.2	Connection boards PA or NA (only 2.2- 5 kN).....	138
27.2.3	Potentiometers	138
27.3	Putting the actuator into operation	138
27.4	Diagram.....	139

27.5	Maintenance.....	140
27.6	Dismantlement of thrust actuator	140
27.7	Troubleshooting.....	141
27.7.1	Troubleshooting table.....	142
28	AUTOMATIC VENT VALVE, G8070, F8071	143
29	STOP VALVES FIG 215 AND FIG-216.....	144
30	AUTO FILTER TYPE 6.60	145
30.1	General	145
30.2	Start-up	147
30.3	Control of automatic filter, type 6.60.....	148
30.3.1	Chamber fill up time change.....	150
30.3.2	Flush period change.....	150
30.3.3	Flush time change.....	151
30.3.4	Parameter settings.....	151
30.3.5	Set clock is selected to set time and date.	151
30.4	Maintenance.....	152
30.4.1	Servicing tools.....	153
30.4.2	Candle element cleaning agent "BOLL CLEAN 2000"	154
30.5	Manual cleaning of the candle filter elements	155
30.6	Maintenance instructions (by-pass filter).....	156
30.7	Part lists	159
30.7.1	Part list for type 6.60.1	159
30.7.2	Part list for type 6.60	163
31	PRESSURE VESSELS.....	168
32	HOW TO ORDER SPARE PARTS	169

1 STORAGE, HANDLING AND INSTALLATION

1.1 Storage

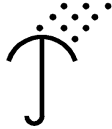

The unit is to be protected from rain, snow and dirt. In order to avoid condensation, it is recommended to avoid temperature variation.

Storage temperature -10 to +60°C
Ambient humidity max. 85%

1.2 Handling

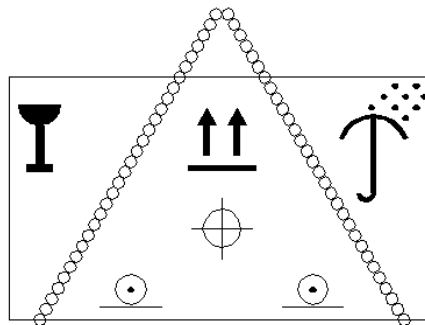

packed unit

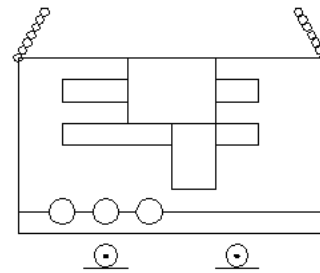

unpacked unit



Unit is handled from lift hangers or with forklift truck. Used lifting device is to have adequate lifting capacity and break resistance, and it is prohibited to be under lifted load.

1.3 Installation

Package material is wood and plastic. Package materials are to be disposed or recycled according to local law.

Before final installation and fastening of the unit, the following is to be taken into account:

Visual inspection is recommended in order to see possible damages caused by transport or moving to the installation place.

Needed service space can be seen in the general arrangement drawing.

Installation place is to be as vibration free as possible.

Installation place must have adequate ventilation in order to prevent explosion danger.

The unit must be fastened with bolts or by welding, see general arrangement drawing. Additional bracing of booster unit must be done if vibration is detected.

Plugs of pipe connections are to be removed before installing pipes to fuel oil unit.

It is recommended that all HFO pipelines connected to fuel oil units are insulated and trace heated.

Pipeline connections can be seen in the general arrangement drawing.

Electrical connections can be seen in the interconnection pages of the electric drawings.

Protective bonding to be executed according to the standards of the installation place.

Before start-up, activate the gas generator of the SealGuard, if installed.

2 SAFETY INSTRUCTIONS



1. Read the instruction manual for the unit.
2. Wear protective clothing, ear defenders and eye protection. Danger of burning lesion. Beware of hot surfaces, hot oil and noise.
3. Switch voltage off before maintenance occurs.
4. Electrical work must be carried out according to the standards by authorised persons.
5. Close shut off valves from both sides and depressurise the equipment and pipes before any maintenance action. To prevent danger of hot liquid/steam spray.
6. Use crane to lift heavy parts during maintenance and ensure that parts removed come off in a controlled manner.
7. After maintenance, ensure that all parts are assembled correctly.
8. Ensure that the safety instructions for all cleaners, oils and paints are available.
9. Keep the environment of the unit clean. "Slippery floors may cause injury."
10. Smoking is not allowed in the immediate surroundings of fuel oil units.
11. Unwanted equipment and chemicals should be disposed of in a safe manner and according to local laws and regulations.

3 WARNINGS AND INSTRUCTIONS



1. Pumps start automatically after power failure.
2. Run only one pump and heater simultaneously. Switch the other pump to stand-by.
3. Ensure fuel oil flow through intended heater.
4. Turn trace heating on if unit is stopped during HFO running.
5. Keep the feeder pressure setting at least at 3 bar.
6. Do not heat LFO/MDO above 50°C.
7. Do not adjust feeder/booster pressure from pumps.
8. Do not run pumps dry.
9. Electric heaters and steam/thermal oil control valve are interlocked with booster pumps viscometer and HFO/LFO, MDO three way valve.
10. It is recommended that all HFO pipelines connected to fuel oil units are insulated and trace heated.
11. In case of no instrument air by pass filter is to be used.
12. Make sure that the operating pressure of the pressure vessel does not exceed the design pressure, that the temperature of the pressure vessel's contents does not exceed the maximum allowed operating temperature and that- the connections do not leak.

4 START-UP

Before start-up, activate the gas generator of the SealGuard, if installed.

1. Switch main switches and all control switches of the unit to off position.
2. Switch instrument air on to fuel oil units.
3. Ensure LFO/MDO flow to feeder/booster unit. Suction pressure gauge of the unit should indicate pressure (>0 bar). Open the equipment valves of feeder/booster unit and close by-pass valves.
4. Check that valves of the engine(s) are in right position.
5. Ensure that fuel oil from engine(s) flows to booster unit's mixing tank.
6. Ensure that all miniature circuit breakers, motor circuit breakers and moulded case circuit breakers are switched on in local control panel(s) of the fuel oil unit(s).
7. Switch main switch to on position.
8. After resetting the alarm panel, the following alarms should be on. Low outlet pressure (if installed), low level in mixing tank, low viscosity (if not blocked with signal from HFO/LFO, MDO valve).
9. Start feeder pump and check rotation direction.
10. To fill fuel oil unit and pipelines to and from engine(s) with LFO/MDO will take from two to ten minutes.
11. Low level in mixing tank alarm will go off after tank is filled. In case of manual deaeration open the deaeration valve until the low level alarm goes off.
12. Pressure in fuel oil unit and engine(s) should rise to range from three to five bar. If not, check positions of valves.
13. Change running feeder pump. Check rotation direction. Use always one pump as running and one pump as stand-by. Change running pump periodically in order to run pumps equally.
14. Check that steam/thermal oil valves are closed and electric heaters are off.
15. Start booster pump. Check rotation direction. Pressure in pipelines after booster pumps should rise to range from six to nine bar (setting in engine's equipment). Low outlet pressure alarm goes out (if installed).
16. Change running booster pump. Check rotation direction. Use always one pump as running and one pump as stand-by. Change running pump periodically in order to run pumps equally.
17. Start viscometer. Viscosity of LFO/MDO is in range from three to eight mPas.
18. Low viscosity alarm is on (if not blocked with signal from HFO/LFO, MDO valve).
19. Start auto filter.
20. Start engine.
21. Change fuel oil from LFO/MDO to HFO.
22. Ensure that needed trace heating is on.

23. If there is HFO/LFO, MDO valve in feeder/booster unit turn it to HFO position.
24. Open steam/thermal oil valves or switch electric heater on by control switch at local control panel.
25. Ensure the operation of viscosity/temperature controller if they are not installed to local control panel by Auramarine Ltd.
 - a) Choose controller by control switch at local control panel.
 - b) Set setpoint above process value. Control valve should open or stages of electric heater should increase power.
 - c) Set setpoint below process value. Control valve should close or stages of electric heater should decrease power.
 - d) In case of malfunction, check wiring.
 - e) Set setpoint to normal and viscosity control on.
26. Low viscosity alarm goes out after engine has consumed all LFO/MDO from circulation.
27. After engine has run from 1,5 to 2 hours with HFO, check all pipe connections, and in case of leakage, tighten the pipe connection.

Attention

Fuel oil viscosity can be regulated by viscosity or by temperature.

Recommended way is to use viscosity control, because it keeps the injection viscosity constant regardless of the fuel oil quality by regulating temperature.

As back-up fuel oil viscosity can be controlled by temperature.

Selection by above mentioned controls is done by control switch at local control panel and valves of heaters and valves of steam/thermal oil lines.

5 SHUTDOWN

1. Circulate the fuel oil through heater at least ten minutes after turning heating off in order to cool the heater down.
2. Turn the trace heating on if there is HFO in pipe system of the fuel oil unit.

6 TROUBLE SHOOTING

Problem	Check points / actions
Stand-by pump starts.	<p>Open suction valves if they are closed. Suction pressure should be above -0,5 bar, if below clean the suction strainers. Setpoint of pressure control valve should be 4-5 bar. The by-pass valve of the pressure control valve should be closed. Check rotation direction of pumps. Check pressure control valve setting at engine(s) equipment. Ensure that fuel oil from engine(s) flows to booster unit's mixing tank. The shut of valve of the pressure switch should be open. The deaerating valves of the heaters and mixing tank should be closed. Check the operation of the auto filter and by-pass filter of the auto filter. Check the operation of the pressure switch and the alarm panel Check the settings and cleanness of the internal over flow valves of the pumps. Check that the delay of the stand-by pump start is sufficient.</p>
Pressure too high at pump outlet.	<p>Check positions of valves Run only one feeder and one booster pump simultaneously. Setpoint of pressure control valve at engine(s) equipment may be too high. Clean the heaters. Check the operation of the auto filter and by-pass filter of the auto filter.</p>
Heating is not working.	<p>Check the positions of the steam/thermal oil valves. Moulded case circuit breakers of the electric heaters should be on. Safety thermostats of the electric heaters may be tripped. Control switch of the electric heater should be on. Viscometer is not running. The by-pass valve of the heater should be closed. HFO/MDO, LFO valve should be in HFO position.</p>
Viscometer is not working.	<p>Check positions of control switches at local control panel. Viscometer should be on and viscosity control should be selected. Check wiring of the controller and viscosity measuring loop. By-pass valve of the viscometer should be closed. Check the selector switch of density at viscometer.</p>
Low level in mixing tank.	<p>Feeder pump is not running. Fuel from engine does not flow to the mixing tank of booster unit.</p>
Flow meter is not working.	<p>Check the cleanness of the flowmeter filter and rotor. The valves of the flow meter are closed. The by-pass valve of the flow meter is dirty. Check wiring and settings if there are out going signals.</p>
Safety valve is open.	<p>Working pressure is above the setpoints of the safety valves. Setpoint at mixing tank is 10 bar and at heaters 15 bar. Valves after heaters should be open. Safety valve is damaged.</p>

7 MAIN SWITCH

Door of the control panel can be opened with main switch on by pressing with a pin to hole shown below.



8 ELECTRONIC TIMER, CT-S RANGE, TYPE 1SVR6300

8.1 Operating controls

- Adjustment of the time range by selecting the max. value:

Range	Max. value
0.15 - 3 s	>> 3 s yellow
1.5 - 30 s	>> 30 s dial
15 - 300 s	>> 300 s
1.5 - 30 min	>> 30 min
15 - 300 min	>> 300 min
1.5 - 30 h	>> 30 h
15 - 300 h	>> 300 h
0.05 - 1 s	>> 1 s white
0.5 - 10 s	>> 10 s dial
5 - 100 s	>> 100 s
0.5 - 10 min	>> 10 min

- Direct reading scale to set the time value within the chosen range
- Function / Selection of the function on CT-MFS and CT-MBS
Functions: see III
- Setting of the 2nd c/o contact as an instantaneous contact
Position Inst. "I": Instantaneous contact
- Status display with LEDs:

U/T: green LED Status indication of control supply voltage and timing

Control supply voltage applied
 Time delay is running

R: yellow LED - Status indication of output relay

energized

R1/R2: yellow LED - Status indication of output relay 1/2

energized

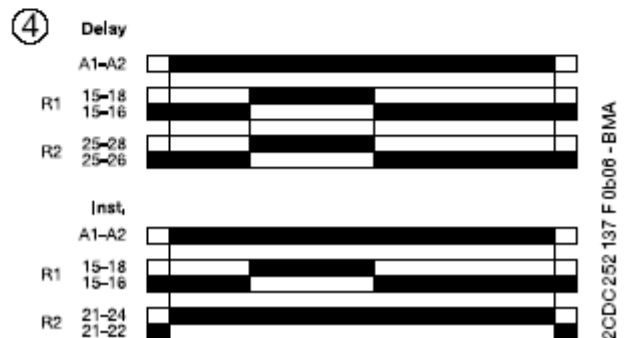
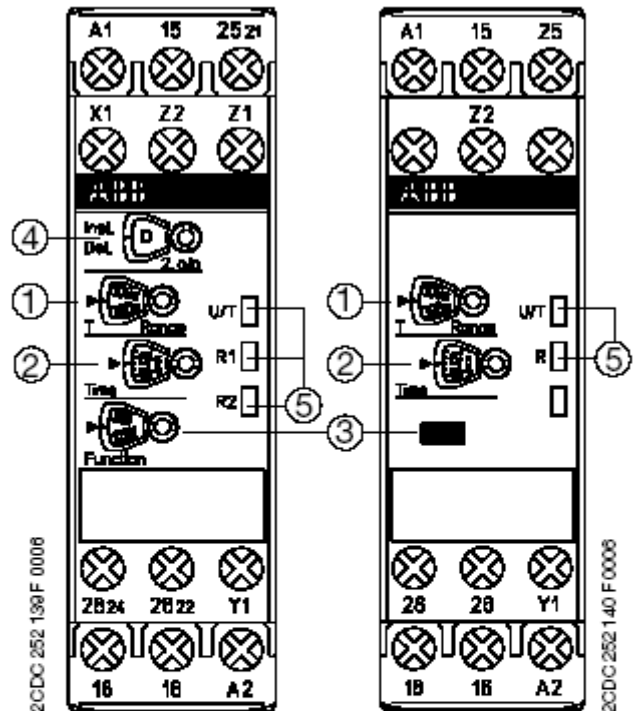

8.2 Electrical diagram



For the rated control supply voltage and the circuit diagram, see label at the side of the unit

A1-A2
Y1-Z2
X1-Z2

Control supply voltage U_s
Control input to start timing
Control input to pause timing / accumulative function (see diagram under V)

Z1-Z2

Remote potentiometer connection for the fine adjustment of the time delay. When an external potentiometer is connected, the internal, front-face potentiometer is disabled.

15-16/18

1st c/o contact

25-26/28

2nd c/o contact

(21)-(22)/(24)

2nd c/o contact, set as instantaneous contact

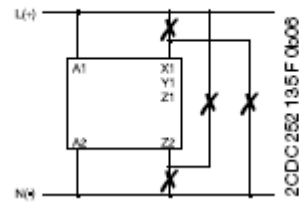
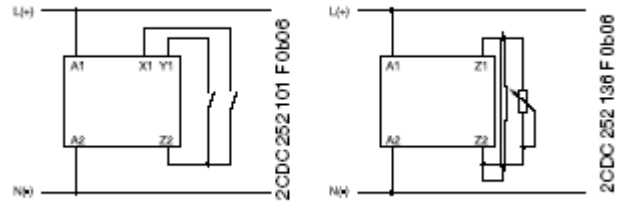

8.3 Function diagrams

CT-MBS and CT-MFS

1.  ON-delay
t adjusted time delay

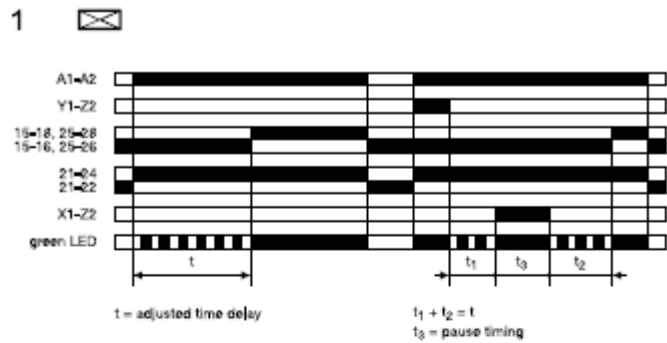

2C/DC 252 018 F 0206 - BMA

2.  Impulse-ON
t adjusted pulse time

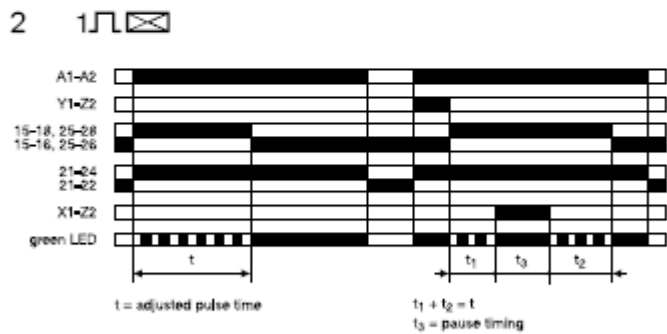

2C/DC 252 025 F 0206 - BMA

3.  Flasher with reset, starting with ON
t adjusted flashing time

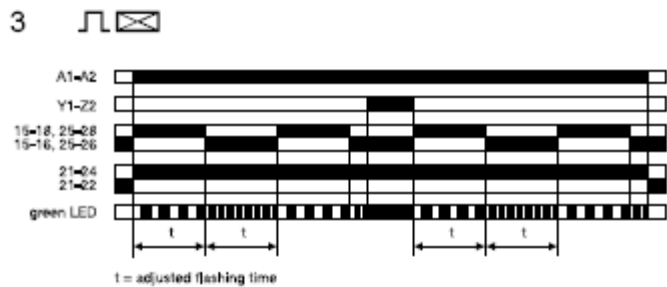

2C/DC 252 031 F 0206 - BMA

4.  Flasher with reset, starting with OFF
t adjusted flashing time

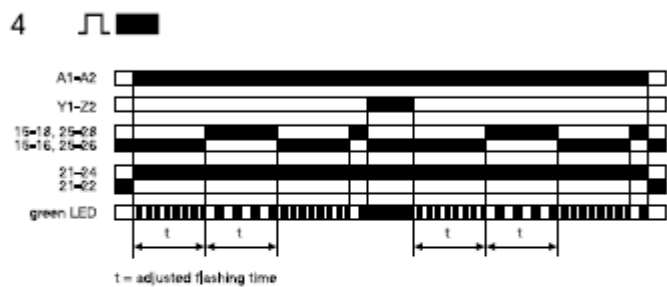

2C/DC 252 032 F 0206 - BMA

5.  OFF-delay with auxiliary voltage
t adjusted time delay

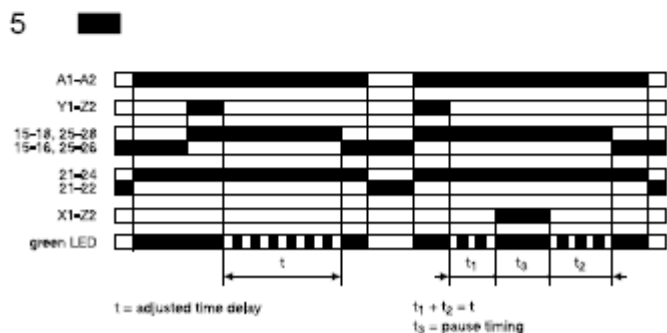

2C/DC 252 019 F 0206 - BMA

6.  Impulse-OFF with auxiliary voltage
t adjusted pulse time

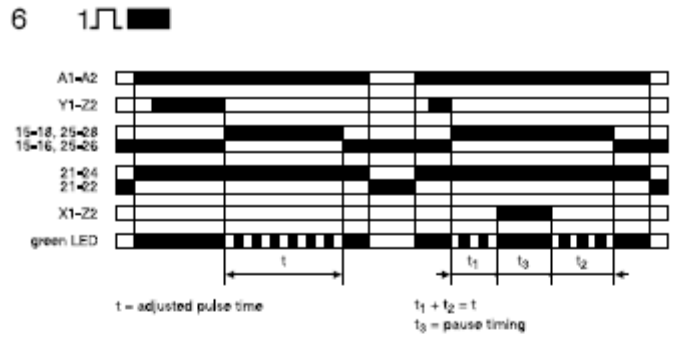

2C/DC 252 026 F 0206 - BMA

7.  Star-delta change-over with impulse function
t1 adjusted starting time
t2 fixed transition time of 50 ms

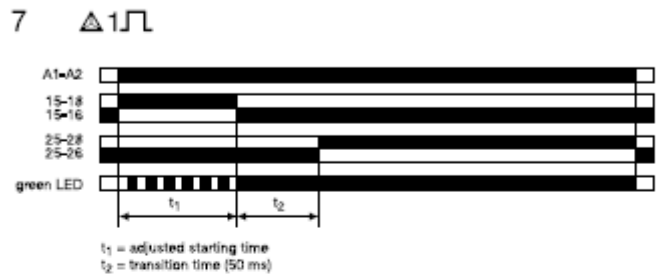

2C/DC 252 030 F 0206 - BMA

8.  ON-delay and OFF-delay, symmetrical
t1 adjusted ON-delay
t2 adjusted OFF-delay

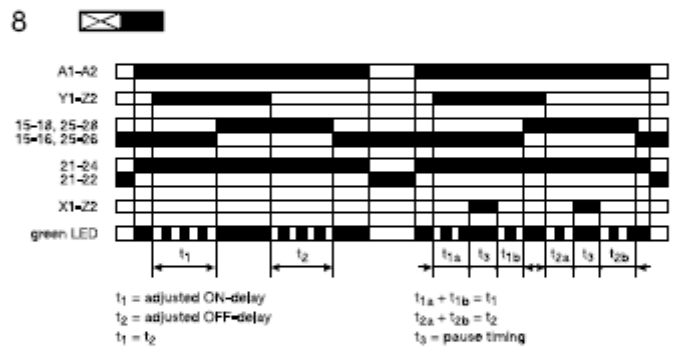

2C/DC 252 022 F 0206 - BMA

9.  Pulse former
t adjusted pulse time

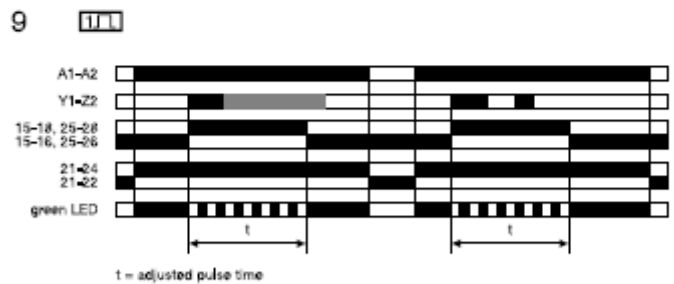

2C/DC 252 034 F 0206 - BMA

10.  ON/OFF-Function
ON-Function - time sector \neq 300 h
OFF-Function - time sector = 300 h

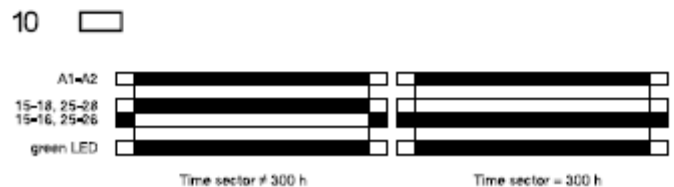

2C/DC 252 044 F 0206 - BMA

CT-AHS

5. OFF-delay with auxiliary voltage
t adjusted time delay

CT-ARS

11. OFF-delay without auxiliary voltage
t adjusted time delay

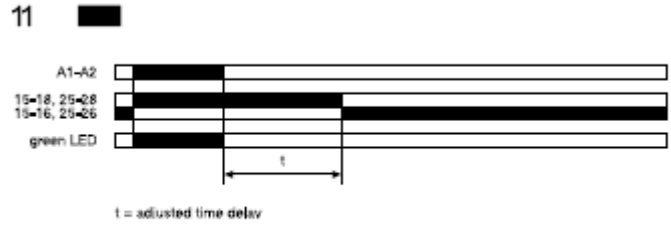

2CDC 252 02 1 F 0206 - BMA

8.4 Factory settings by Auramarine Ltd.

Duty	Mode	Setting
delay of stand-by start (delay on release)	5	3 seconds

5

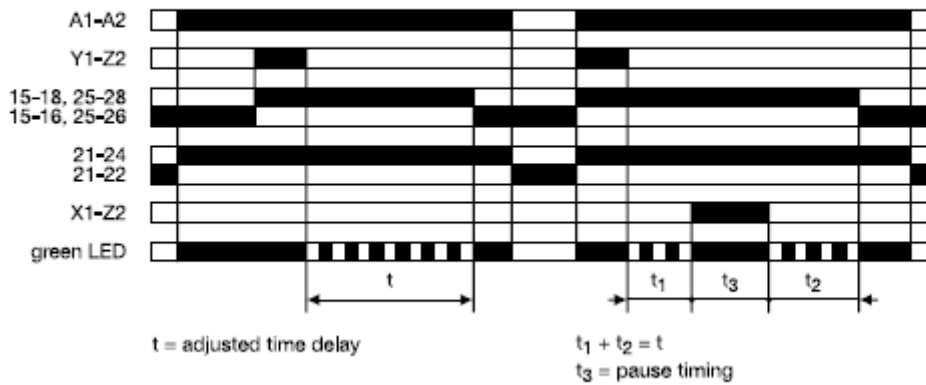

2CDC 252 019 F 0206 - BMA

9 COUNTER, TYPE H7E



The product has a built-in lithium battery. Do not short-circuit the + and - terminals, charge, disassemble, deform, or expose the battery to fire. The battery may explode (break), catch fire, or cause liquid leakage.

Do not use any battery other than the specified one (Y92S-36). Using another battery may cause liquid leakage or breakage, resulting in malfunction or injury.

If a voltage other than the rated one is applied, internal elements may be damaged.

Do not use the Counter in locations subject to direct sunlight, subject to corrosive gases or subject to dust.

Nomenclature

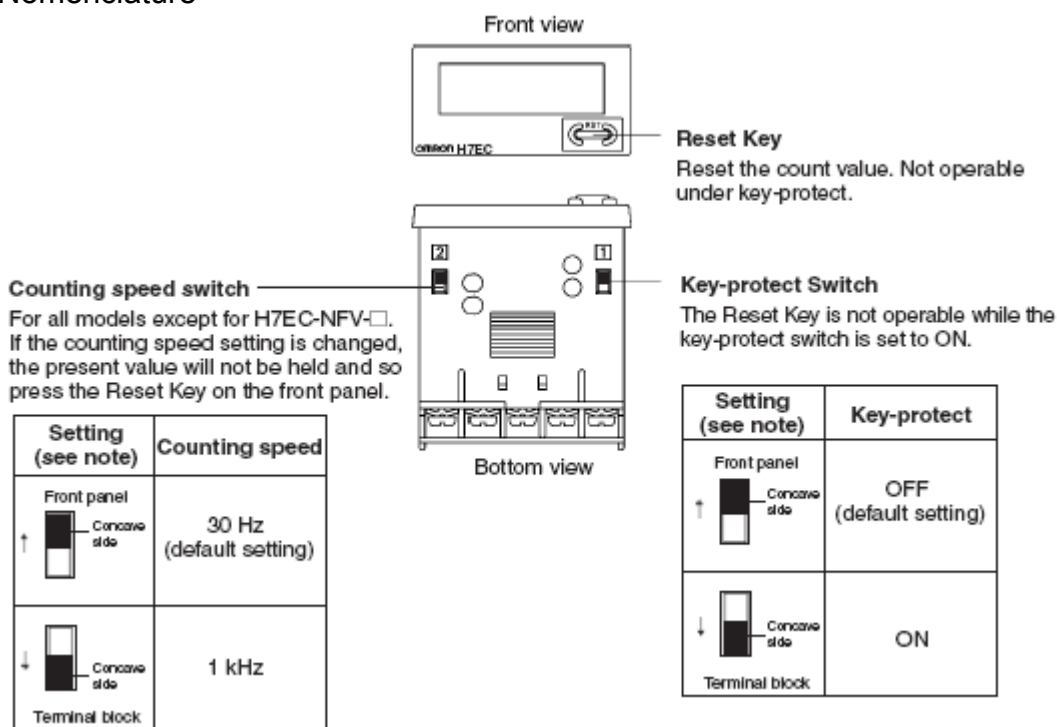

Battery replacement

Remove the wiring when replacing the battery. Do not come in contact with any item to which high voltage is being applied. Doing so may result in electric shock.

Before changing the Battery, the person should ensure that they are not carrying any static electric charge.

Procedure for replacing the Battery (refer to the diagrams below):

1. Using the tool, pry open the lift-tab on the case. (1)
2. Pull the body out of its outer case. (2)
3. Lift the Battery up by the edge and remove it. (3)

When removing the Battery, do not come in contact with the display area or any internal parts.

4. Wipe the back of the new battery before inserting it.
5. Ensure that the + and – terminals are correctly oriented.
6. After replacing the Battery, re-insert the body into its case. (4)

Check that the case is securely held in by the lift-tab

7. Press the Reset Key before use (not necessary for H7ER-N, -NV, -NV1). (5)

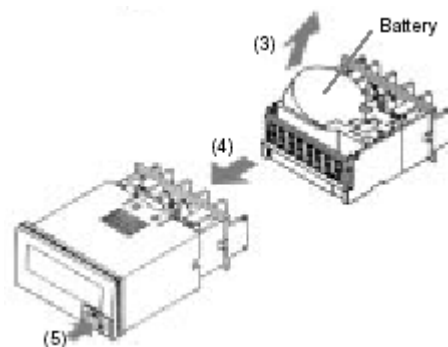
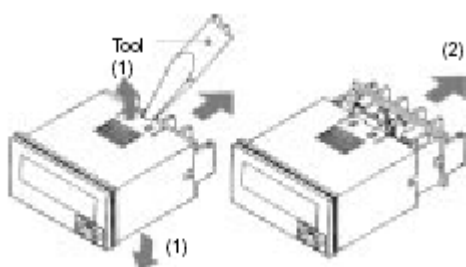

10 ALARM PANEL



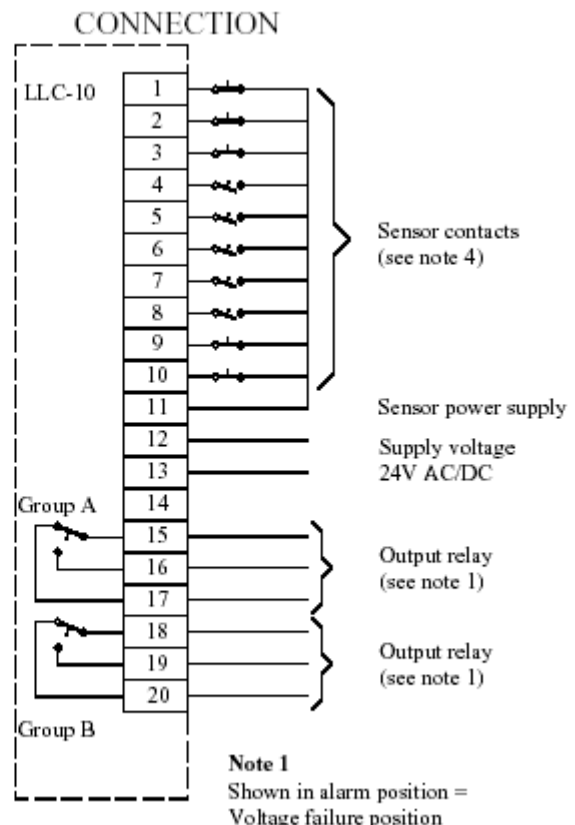
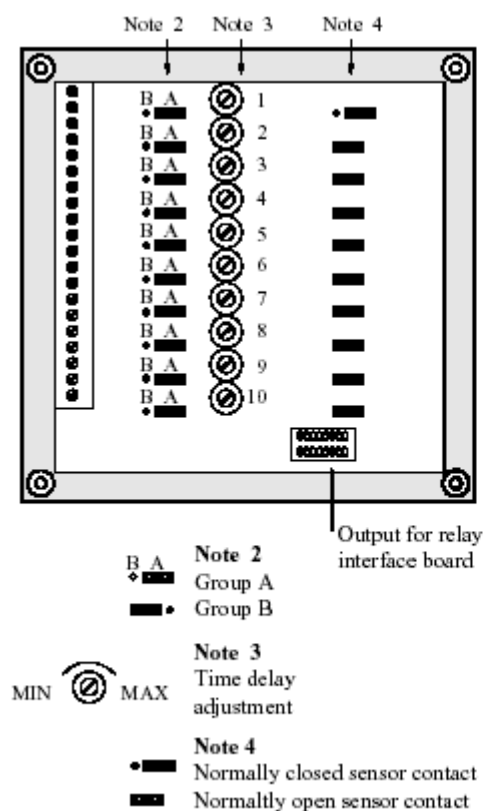

LLC-10 is a compact alarm display unit in the "DIN"-series. It is designed for exacting applications. The unit is programmable for use with either normally open or closed sensor contacts, and with adjustable time delay for each alarm channels. The alarm channels can be connected to either of the two output groups (A and B alarms). At the panel, the sensors indicator flashes when the pre-set time delay has elapsed. At the same time the output group to which it is connected, is activated. The signal is acknowledged by pressing the red RESET button. This releases the output contact and the flashing light becomes steady. When the fault has been corrected and the sensor contact has returned to its normal state, the indicator lamp goes out. If the fault self-corrects and the sensor contact returns before acknowledgement, the fault remains in the unit memory, the light flashes and the output contact remains activated, until the accept button is pressed. LLC-10 is equipped with a channel memory. The unit is always ready to receive new alarm signals, independent of system status. The panel can be provided with legends for each alarm channel or with a common 10 points legend.

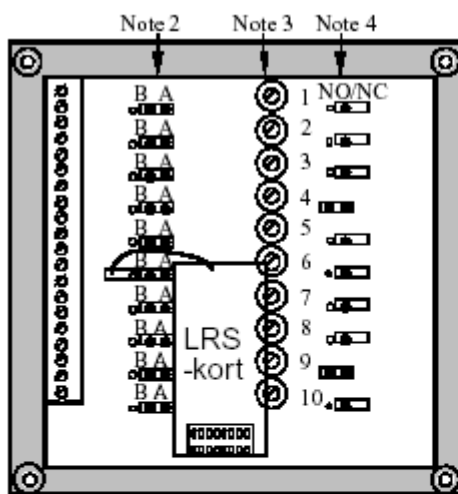

10.1 Alarm panel for units with LRS classification

LLC-10 LRS is a compact alarm display unit in the "DIN"-series. It is designed for exacting applications. The unit is programmable for use with either normally open or closed sensor contacts, with adjustable time delay. The alarm system has two output groups (A and B alarms). All channels shall be connected for A-alarm. At the panel, the sensors indicator flashes when the pre-set time delay has elapsed. At the same time the both output group is activated (the B group is delayed 5 sec. in relation to the A group). If a new sensor will be activated the B group relay will do a quick status change. The signal is acknowledged by pressing the red RESET button. This releases the output contact and the flashing light becomes steady. When the fault has been corrected and the sensor contact has returned to its normal state, the indicator lamp goes out. If the fault self-corrects and the sensor contact returns before acknowledgement, the fault remains in the unit memory, the light flashes and the output contact remains activated, until the accept button is pressed. LLC-10 is equipped with a channel memory. The unit is always ready to receive new alarm signals, independent of system status. The panel can be provided with legends for each alarm channel or with a common 10 points legend.



- Note 2**
 Grupp A, All channels shall be connected for A-alarm
 Grupp B, the LRS-card shall be connected to B-alarm.
- Note 3**
 Time delay adjustment
 MIN MAX
- Note 4**
 Normally closed contact
 Normally open contact

CONNECTION

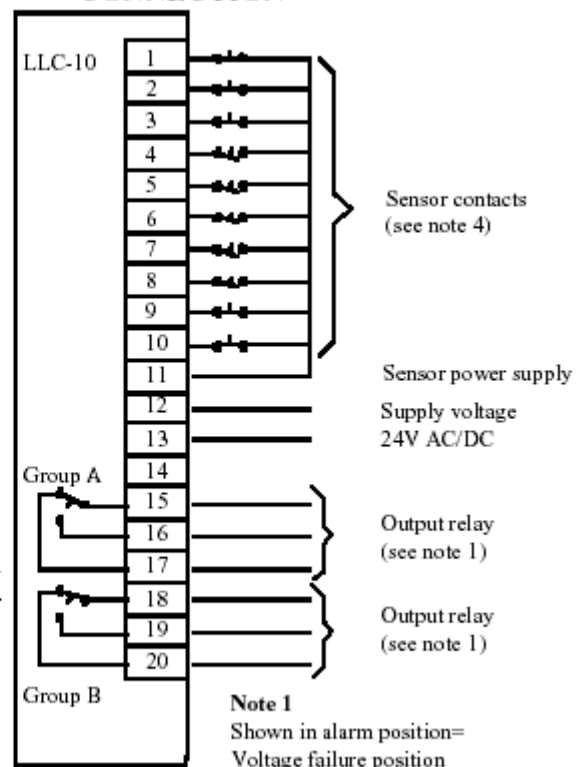

11 VISCOSITY AND TEMPERATURE CONTROLLERS E5EK

Precautions

General Precautions

Operating environment

Keep within the rated ambient operating temperature, ambient operating humidity, and storage temperature ranges.

Use the Unit according to the vibration resistance, shock resistance and enclosure ratings.

Do not use the Unit in places with corrosive gas or excessive dust.

Do not use the Unit nearby machines generating high frequency noise.

Correct use

Mounting

The dimensions of the Digital Controller conform to DIN 43700

Recommend panel thickness is 1 to 8 mm.

Mount the Unit horizontally.

Connection

To reduce inductive noise influence, the lead wires connecting the input type of the Digital Controller must be separated from the power lines and load lines

Use the specified compensating conductors for thermocouples.

Use lead wires having small resistance for platinum resistance thermometers

Connection Example

Wire the terminals of the Unit using solderless terminals.

The tightening of the torque applied to the terminal screws of the Unit must be approximately 0.78 N*m or 8 kgf*cm

Use the following type of solderless terminals for M3.5 screws-

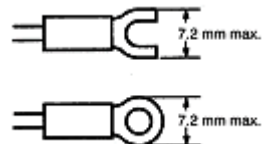

Operation

The alarm outputs of the model with an alarm function may not turn ON properly when the model malfunctions. The use of alarm equipment with the model is recommended.

The parameters and internal switch are set before shipping so that the Unit will function normally. Change the settings of the parameters and internal switch according to the application if necessary.

Several seconds are required until relay is turned ON after power has been supplied to the Digital Controller. Therefore, take this time delay into consideration when designing sequenced circuits which incorporate a Digital Controller.

Do not use excessive force when drawing out the internal mechanism from housing. Protect against static discharge when changing the settings of the internal switch. Changing the settings on a grounded conductive mat is recommended.

When connecting the Control Output Unit to the Temperature Controller or Digital Controller, make sure that the Control Output Unit is a suitable type. The use of an improper type of Control Output Unit may cause the system to malfunction.

The heater burnout alarm will not be available if the Linear output Unit is used.

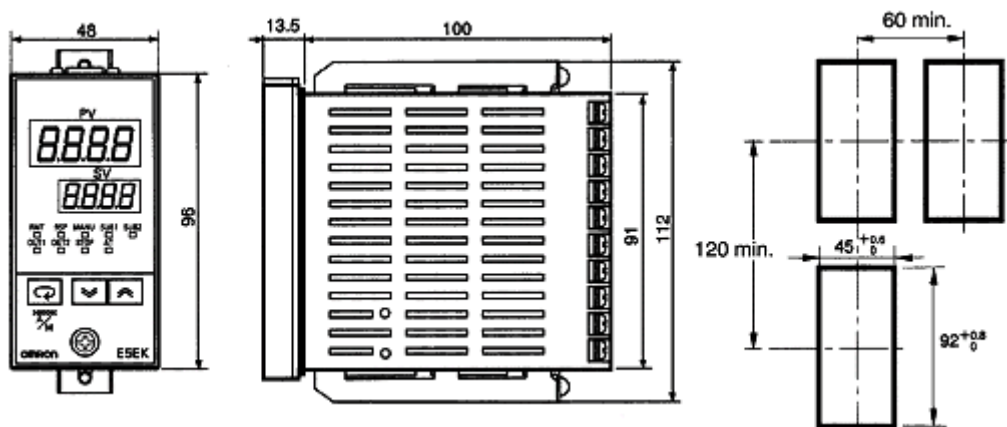

Note:

1. Recommended panel thickness is 1 to 8 mm.
2. Maintain the specified vertical and horizontal mounting space between each unit. Units must not be closely mounted vertically and horizontally.

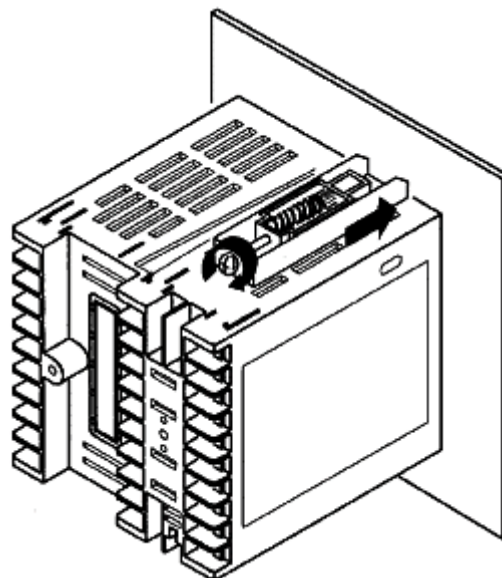
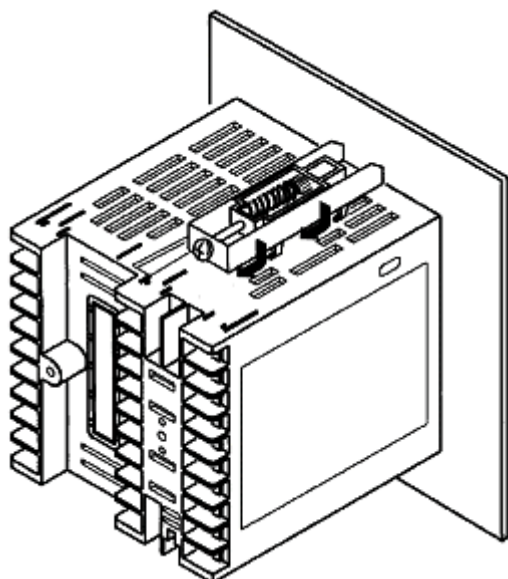

1. Insert the E5AK Controller into the panel's mounting hole at the position shown in the figure

2. Fit the mounting bracket(accessory) into the fixing slots on the top and bottom of the rear case

3. Tighten the mounting bracket screws on the upper and lower parts of the E5AK in small increments alternately and equally until the ratchet start to slide

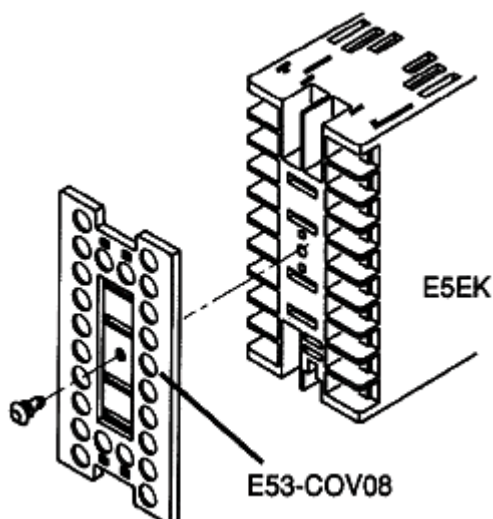

E53-COV0809, E53-COV08 Terminal Cover (Sold Separately)

Fasten the terminals covers as follows by using the snap pins. Snap pins are provided with the terminal covers

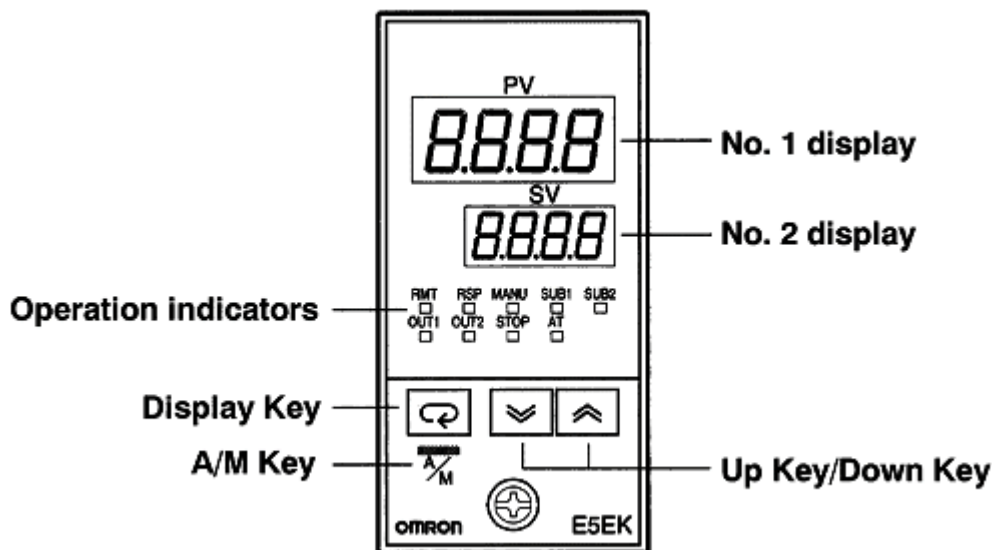

No. 1 display	Displays the process value or parameter symbols
No. 2 display	Displays the setpoint, manipulated variable or parameter settings
Out 1	Lits when the controller increases heat
Out 2	Lits when the controller decreases heat
Sub 1	Lits when the low viscosity alarm is on
Sub 2	Lits when the high viscosity alarm is on
Manu	Lits when the manual operation mode is on
Stop	Lits when operation has stopped
RMT	Lits during remote operation (not in use by Auramarine)
RSP	Lits during remote SP operation (not in use by Auramarine)
AT	Flashes during auto tuning

A/M key Each press of this key switches between the auto and manual operations.

Display key The functions of this key change according to how long it is pressed. If the key is pressed for less than one second, the parameters are switched. If the key is pressed for one second or more, the menu display appears.

Up/down-keys Each press of the up-key increments or advances the values or settings on the no. 2 display, while each press of the down-key decrements or returns the values or settings on the no. 2 display.

E.g. in the normal run situation setpoints can be changed by pressing up or down keys.

11.1 Operation

Parameter settings are done by Auramarine Ltd. according to the lists below.

After power is switched on, controller starts to operate. Setpoint can be changed by pressing up or down key. Viscosity controller uses mPas and temperature controller °C.

Manual operation is executed by first pressing A/M key (MANU lits) and then operating with up key and down key. Return to auto operation by pressing A/M key (MANU goes out).

Controller can be auto tuned by setting the setting of the parameter At from Level 1 to AT-2. Auto tuning can be cancelled by setting the setting of the parameter At to OFF.

Ensure the operation of viscosity/temperature controller, if they are not installed to local control panel by Auramarine Ltd.

- a) Switch viscometer and booster pump on.
- b) If there is HFO/LFO, MDO valve in feeder/booster unit, turn it to HFO position.
- c) Open steam/thermal oil valves or switch electric heater on by control switch at local control panel.
- d) Choose controller by control switch at local control panel.
- e) Set setpoint above process value. Control valve should open or stages of electric heater should increase power.
- f) Set setpoint below process value. Control valve should close or stages of electric heater should decrease power.
- g) In case of malfunction, check wiring.
- h) Set setpoint to normal and viscosity control on.

In case of trouble, the following should be checked:

- 1) Connections are done according to the electrical drawings.
- 2) Controller is supplied with AC 100...240 V 50/60 Hz.
- 3) Transmitter of process value gives correct signal. Signal error is displayed in no.1 display "S.Err".
- 4) Parameter settings are according to the lists below.

In case of process value hunting, it is recommended to increase the setting of the parameter I (integral time) at level 1. If it does not help, it is recommended to increase also the setting of the parameter P (proportional band) at level 1.

11.2 Access to parameters

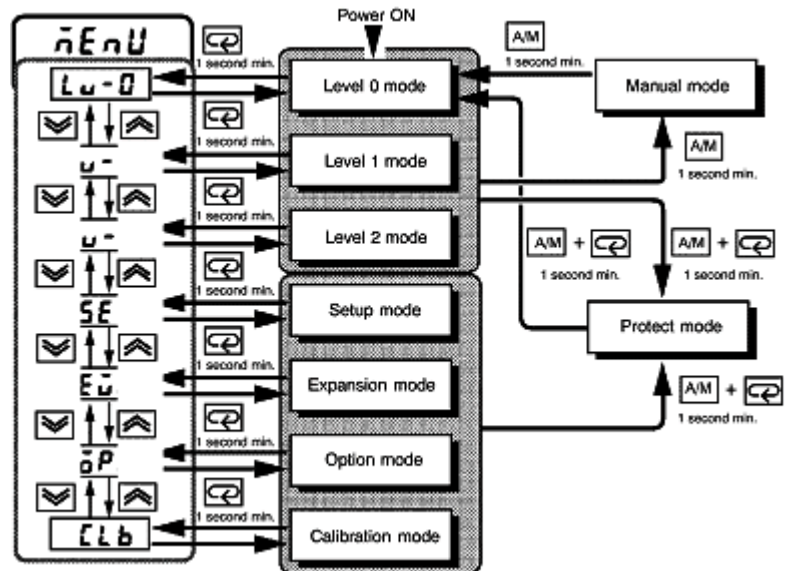
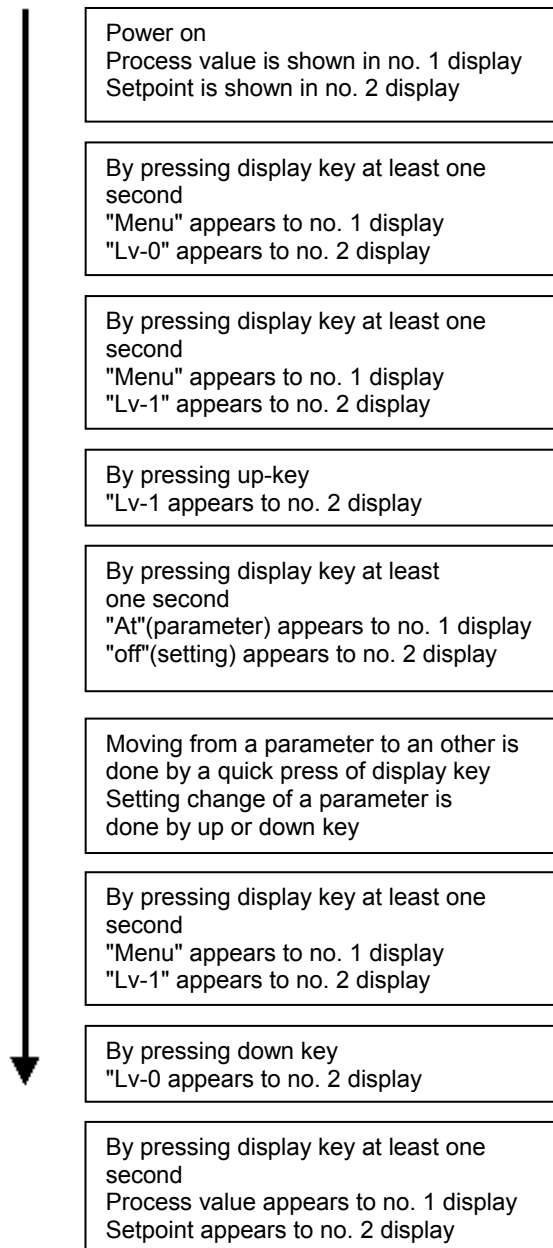

Protect mode is set to 3 to allow changes only at levels 0 and 1, and it is not recommended to go any other levels.

Access to other levels by pressing A/M key and display key simultaneously at least one second until "SECr" appears to no. 1 display and then changing 3 to 1 to no. 2 display by pressing down key. Exit from protect mode is done by pressing A/M key and display key simultaneously at least one second.

11.3 Parameter settings of the viscosity controller A16A1

If setting column is empty default is used.

Mode	Parameter Name	Setting Range	Unit	Default	Remarks	Setting
Protect	SECr Security	0 to 6	None	1		3
	KEYP [A/M] key protect	ON/OFF	None	OFF		
Manual	Manual MV	-5.0 to 105.0 *1	%	0.0		
Level 0	Set Point	Set point lower limit to Set point upper limit	EU	0		
	r-s Run/Stop	Run/Stop	None	Run		
Level 1	AT AT Execute/Cancel	OFF/AT-1/AT-2	None	OFF	During running	
	SP-0 Set point 0	Set point lower limit to Set point upper limit	EU	0	Multi-SP	
	SP-1 Set point 1	Set point lower limit to Set point upper limit	EU	0	Multi-SP	
	SP-2 Set point 2	Set point lower limit to Set point upper limit	EU	0	Multi SP	
	SP-3 Set point 3	Set point lower limit to Set point upper limit	EU	0	Multi-SP	
	AL-1 Alarm value 1	-1999 to 9999	EU	0		3
	AL-2 Alarm value 2	-1999 to 9999	EU	0		3
	AL-3 Alarm value 3	-1999 to 9999	EU	0		
	P Proportional band	0.1 to 999.9	%FS	10.0		10
	I Integral time	0 to 3999	sec	233		240
	d Derivate time	0 to 3999	sec	40		0
	C-SC Cooling coefficient	0.01 to 99.99	None	1.00	At heating and cooling control	
	C-db Dead band	-19.99 to 99.99	%FS	0.00	At heating and cooling control	
	Db Position-proportional dead band	0.1 to 10.00	%	2.0	At position-proportional control	0.3
	mF-r Manual reset value	0.0 to 100.0	%	50.0		
	HYS Hysteresis (heat)	0.01 to 99.99	%FS	0.10		
	CHYS Hysteresis (cool)	0.01 to 99.99	%FS	0.10	At heating and cooling control	
	CP Control period (heat)	1 to 99	sec	20		
	C-CP Control period (cool)	1 to 99	sec	20	At heating and cooling control	
	Hb Heater burnout	0.0 to 50.0	A	0.0	Heater burnout detection	
Level 2	r-L Remote/Local	RMT/LCL	None	LCL	Communications units settings	
	SPmd SP mode	RSP/LSP	None	LSP		
	SPrU SP ramp time unit	M(Minutes) / H(Hours)	None	M		
	SPrs SP ramp set value	0 to 9999	EU	0		
	LBA LBA detection time	0 to 9999 *1	sec	0		
	mv-S MV at stop	-5.0 to 105.0 *1	%	0.0		HOLD
	mv-E MV at PV error	-5.0 to 105.0 *2	%	0.0		HOLD
	ML-H MV upper limit	MV lower limit + 0.1 to 105.0 *3	%	105.0		
	ML-L MV lower limit	-5.0 to MV upper limit -0.1	%	-5.0		
	MrL MV change rate limit	0.0 to 100.0	%/sec	0.0		
	InF Input digital filter	0 to 9999	sec	0		
	OC-H Open/close hysteresis	0.1 to 20.0	%	0.8		0.5
	ALH1 Alarm 1 hysteresis	0.01 to 99.99	%	0.02		1.0
	ALH2 Alarm 2 hysteresis	0.01 to 99.99	%	0.02		1.0
	ALH3 Alarm 3 hysteresis	0.01 to 99.99	%	0.02		
	InSH Input shift upper limit	-199.9 to 999.9	°C/°F	0.0	Temperature input	
	InSL Input shift lower limit	-199.9 to 999.9	°C/°F	0.0	Temperature input	

*1 During heat and cooling control, the lower limit becomes -105.5%. During position-proportional control the setting becomes HOLD, OPEN or CLOSE. *2 During heat and cooling control, the setting range becomes 0.0 to 105.0%. *3 During heat and cooling control, the setting range becomes -105.0 to 0.0%.

Mode	Parameter Name	Setting Range	Unit	Default	Remarks	Setting
Setup	In-T Input type	0 to 21	None	2		17
	In-H Scaling upper limit	Scaling lower limit +1 to 9999 *4	EU	-100	Analog input	50
	In-L Scaling lower limit	-1999 to SP setting upper limit 0.1*4	EU	0	Analog input	0
	dP Decimal point	0 to 3	None	0	Analog input	
	d-U °C/°F selection	°C/°F	None	°C	Temperature input	
	InIT Parameter initialize	Yes/No	None	No		
	OUT1 Control output 1 assignment	Heat/Cool/Alarm1/Alarm2/Alarm3/HBA/LBA	None	HEAT		
	OUT2 Control output 2 assignment	Heat/Cool/Alarm1/Alarm2/Alarm3/HBA/LBA	None	AL-1		
	SUB1 Auxiliary output1 assignment	Alarm1/Alarm2/Alarm3/HBA/LBA/ S.ERR/E333/RSER	None	AL-2		AL1
	SUB2 Auxiliary output 2 assignment	Alarm1/Alarm2/Alarm3/HBA/LBA/ S.ERR/E333/RSER	None	AL-3		AL2
	ALT1 Alarm 1 type	1 to 11	None	2	Output assignment needer	3
	AL1n Alarm 1 open in alarm	N-O/N-C	None	N-O	Output assignment needer	N-C
	ALT2 Alarm 2 type	1 to 11	None	2	Output assignment needer	2
	AL2n Alarm 2 open in alarm	N-O/N-C	None	N-O	Output assignment needer	N-C
	ALT3 Alarm 3 type	1 to 11	None	2	Output assignment needer	
	AL3n Alarm 3 open in alarm	N-O/N-C	None	N-O	Output assignment needer	
DreV Direct / Reverse operation	OR-R/OR-D	None	OR-R		OR-D	
Expansion	SL-H Set point upper limit	Set point lower limit +1 to scaling upper limit *2	None	1300 *4		50
	SL-L Set point lower limit	Scaling lower limit to Set point upper limit -1 *2	None	-200 *4		0
	CnTL PID/ON/OFF	PID/ON/OFF	None	PID		
	ST ST	OFF/ON	None	OFF		
	ST-b ST stable range	0.1 to 999.9	°C/°F	15.0	ST=ON	
	ALFA α	0.00 to 1.00	None	0.65		
	AT-G AT calculated gain	0.1 to 10.0	None	1.0		
	ReSm Standby sequence reset setting method	0/1	None	0		
	ReM Automatic return of display mode	0 to 99	Sec	0		30
	AT-H AT hysteresis	0.1 to 9.9	%FS	0.2		0.2
LBAB LBA detection width	0.0 to 999.9	%FS	0.2			

*4 When temperature input is selected, the sensor range selected in the "input type" parameter (setup mode) correspond to the scaling upper and lower limit value.

Mode	Parameter Name	Setting Range	Unit	Default	Remarks	Setting
Option	EV-M Multi-SP function	0 to 2	None	0		
	EV-1 Event input assignment 1	NON/STOP/RMT/MAN/RSP	None	NON		
	EV-2 Event input assignment 2	NON/STOP/RMT/MAN/RSP	None	NON		
	SbCT Communication stop bit	1/2	bits	2		
	Len Communication data length	7/8	bits	7		
	Prty Communication parity	None/Even/Odd	None	EVEN		
	BPS Communication baud value	1.2/2.4/4.8/9.6/19.2	kbps	9.6		
	U-no Communication unit No.	0 to 99	None	0		
	Tr-T Transfer output type	SP/SP-M/PV/O/C-O/V-M	None	SP		
	Tr-H Transfer output upper limit	*5	*5	*5		
	Tr-L Transfer output lower limit	*5	*5	*5		
	HbL HBA latch	ON/OFF	None	OFF		
	CALb Motor calibration	ON/OFF	None	OFF		
	MoT Travel time	1 to 999	Sec	1		
	P-db PV dead band	0 to 9999	EU	0		
	rSPU Remote SP enable	ON/OFF	None	OFF		
	rSPH Remote SP upper limit	SP setting lower limit to SP setting upper limit	EU	1300		
	rSPL Remote SP lower limit	SP setting lower limit to SP setting upper limit	EU	-200		
	SPTr SP tracking	ON/OFF	None	OFF		

*5 Set the transfer output type parameter according to the following table.

Transfer Output Type	Transfer Output Lower Limit to Transfer Output Upper Limit
SP :Set point	Set point lower limit to Set point upper limit
SP-M :Set point during SP ramp	Set point lower limit to Set point upper limit
PV :Process value	Scaling lower limit to scaling upper limit
O :Manipulated variable(heat)	-5.0 to 105.0%
C-O :Manipulated variable(cool)	0.0 to 105.0%
V-M :Value opening	-10.0 to 110.0%

- Default : SP
- The output ranges of the SP settings, set point or process value when temperature input is selected are the ranges supported by the selected sensor.
- When the heating side manipulated variable or cooling side manipulated variable is selected, the transfer output lower limit in a heating and cooling control becomes 0.0.

11.4 Parameter settings of the temperature controller A16A2

If setting column is empty default is used.

Mode	Parameter Name	Setting Range	Unit	Default	Remarks	Setting
Protect	SECr Security	0 to 6	None	1		3
	KEYP [A/M] key protect	ON/OFF	None	OFF		
Manual	Manual MV	-5.0 to 105.0 *1	%	0.0		
Level 0	Set Point	Set point lower limit to Set point upper limit	EU	0		
	r-s Run/Stop	Run/Stop	None	Run		
Level 1	AT AT Execute/Cancel	OFF/AT-1/AT-2	None	OFF	During running	
	SP-0 Set point 0	Set point lower limit to Set point upper limit	EU	0	Multi-SP	
	SP-1 Set point 1	Set point lower limit to Set point upper limit	EU	0	Multi-SP	
	SP-2 Set point 2	Set point lower limit to Set point upper limit	EU	0	Multi SP	
	SP-3 Set point 3	Set point lower limit to Set point upper limit	EU	0	Multi-SP	
	AL-1 Alarm value 1	-1999 to 9999	EU	0		10
	AL-2 Alarm value 2	-1999 to 9999	EU	0		10
	AL-3 Alarm value 3	-1999 to 9999	EU	0		
	P Proportional band	0.1 to 999.9	%FS	10.0		2
	I Integral time	0 to 3999	sec	233		240
	d Derivate time	0 to 3999	sec	40		
	C-SC Cooling coefficient	0.01 to 99.99	None	1.00	At heating and cooling control	
	C-db Dead band	-19.99 to 99.99	%FS	0.00	At heating and cooling control	
	Db Position-proportional dead band	0.1 to 10.00	%	2.0	At position-proportional control	0.8
	mF-r Manual reset value	0.0 to 100.0	%	50.0		
	HYS Hysteresis (heat)	0.01 to 99.99	%FS	0.10		
	CHYS Hysteresis (cool)	0.01 to 99.99	%FS	0.10	At heating and cooling control	
	CP Control period (heat)	1 to 99	sec	20		
	C-CP Control period (cool)	1 to 99	sec	20	At heating and cooling control	
	Hb Heater burnout	0.0 to 50.0	A	0.0	Heater burnout detection	
Level 2	r-L Remote/Local	RMT/LCL	None	LCL	Communications units settings	
	SPmd SP mode	RSP/LSP	None	LSP		
	SPrU SP ramp time unit	M(Minutes) / H(Hours)	None	M		
	SPrs SP ramp set value	0 to 9999	EU	0		
	LBA LBA detection time	0 to 9999 *1	sec	0		
	mv-S MV at stop	-5.0 to 105.0 *1	%	0.0		HOLD
	mv-E MV at PV error	-5.0 to 105.0 *2	%	0.0		HOLD
	ML-H MV upper limit	MV lower limit + 0.1 to 105.0 *3	%	105.0		
	ML-L MV lower limit	-5.0 to MV upper limit -0.1	%	-5.0		
	MrL MV change rate limit	0.0 to 100.0	%/sec	0.0		
	InF Input digital filter	0 to 9999	sec	0		
	OC-H Open/close hysteresis	0.1 to 20.0	%	0.8		0.5
	ALH1 Alarm 1 hysteresis	0.01 to 99.99	%	0.02		0.25
	ALH2 Alarm 2 hysteresis	0.01 to 99.99	%	0.02		0.25
	ALH3 Alarm 3 hysteresis	0.01 to 99.99	%	0.02		
	InSH Input shift upper limit	-199.9 to 999.9	°C/°F	0.0	Temperature input	
	InSL Input shift lower limit	-199.9 to 999.9	°C/°F	0.0	Temperature input	

*1 During heat and cooling control, the lower limit becomes -105.5%. During position-proportional control the setting becomes HOLD, OPEN or CLOSE. *2 During heat and cooling control, the setting range becomes 0.0 to 105.0%. *3 During heat and cooling control, the setting range becomes -105.0 to 0.0%.

Mode	Parameter Name	Setting Range	Unit	Default	Remarks	Setting
Setup	In-T Input type	0 to 21	None	2		1
	In-H Scaling upper limit	Scaling lower limit +1 to 9999 *4	EU	-100	Analog input	
	In-L Scaling lower limit	-1999 to SP setting upper limit 0.1*4	EU	0	Analog input	
	dP Decimal point	0 to 3	None	0	Analog input	
	d-U °C/°F selection	°C/°F	None	°C	Temperature input	
	inIT Parameter initialize	Yes/No	None	No		
	OUT1 Control output 1 assignment	Heat/Cool/Alarm1/Alarm2/Alarm3/HBA/LBA	None	HEAT		
	OUT2 Control output 2 assignment	Heat/Cool/Alarm1/Alarm2/Alarm3/HBA/LBA	None	AL-1		
	SUB1 Auxiliary output1 assignment	Alarm1/Alarm2/Alarm3/HBA/LBA/ S.ERR/E333/RSER	None	AL-2		AL1
	SUB2 Auxiliary output 2 assignment	Alarm1/Alarm2/Alarm3/HBA/LBA/ S.ERR/E333/RSER	None	AL-3		AL2
	ALT1 Alarm 1 type	1 to 11	None	2	Output assignment needer	3
	AL1n Alarm 1 open in alarm	N-O/N-C	None	N-O	Output assignment needer	N-C
	ALT2 Alarm 2 type	1 to 11	None	2	Output assignment needer	2
	AL2n Alarm 2 open in alarm	N-O/N-C	None	N-O	Output assignment needer	N-C
	ALT3 Alarm 3 type	1 to 11	None	2	Output assignment needer	
	AL3n Alarm 3 open in alarm	N-O/N-C	None	N-O	Output assignment needer	
	Drev Direct / Reverse operation	OR-R/OR-D	None	OR-R		
Expansion	SL-H Set point upper limit	Set point lower limit +1 to scaling upper limit *2	None	1300 *4		
	SL-L Set point lower limit	Scaling lower limit to Set point upper limit -1 *2	None	-200 *4		
	CnTL PID/ON/OFF	PID/ON/OFF	None	PID		
	ST ST	OFF/ON	None	OFF		
	ST-b ST stable range	0.1 to 999.9	°C/°F	15.0	ST=ON	
	ALFA α	0.00 to 1.00	None	0.65		
	AT-G AT calculated gain	0.1 to 10.0	None	1.0		
	ReSm Standby sequence reset setting method	0/1	None	0		
	ReM Automatic return of display mode	0 to 99	Sec	0		30
	AT-H AT hysteresis	0.1 to 9.9	%FS	0.2		
LBAB LBA detection width	0.0 to 999.9	%FS	0.2			

*4 When temperature input is selected, the sensor range selected in the "input type" parameter (setup mode) correspond to the scaling upper and lower limit value.

Mode	Parameter Name	Setting Range	Unit	Default	Remarks	Setting
Option	EV-M Multi-SP function	0 to 2	None	0		
	EV-1 Event input assignment 1	NON/STOP/RMT/MAN/RSP	None	NON		
	EV-2 Event input assignment 2	NON/STOP/RMT/MAN/RSP	None	NON		
	SbCT Communication stop bit	1/2	bits	2		
	Len Communication data length	7/8	bits	7		
	Prty Communication parity	None/Even/Odd	None	EVEN		
	BPS Communication baud value	1.2/2.4/4.8/9.6/19.2	kbps	9.6		
	U-no Communication unit No.	0 to 99	None	0		
	Tr-T Transfer output type	SP/SP-M/PV/O/C-O/V-M	None	SP		
	Tr-H Transfer output upper limit	*5	*5	*5		
	Tr-L Transfer output lower limit	*5	*5	*5		
	HbL HBA latch	ON/OFF	None	OFF		
	CALb Motor calibration	ON/OFF	None	OFF		
	MoT Travel time	1 to 999	Sec	1		120
	P-db PV dead band	0 to 9999	EU	0		1
	rSPU Remote SP enable	ON/OFF	None	OFF		
	rSPH Remote SP upper limit	SP setting lower limit to SP setting upper limit	EU	1300		
	rSPL Remote SP lower limit	SP setting lower limit to SP setting upper limit	EU	-200		
	SPTr SP tracking	ON/OFF	None	OFF		

*5 Set the transfer output type parameter according to the following table.

Transfer Output Type	Transfer Output Lower Limit to Transfer Output Upper Limit
SP :Set point	Set point lower limit to Set point upper limit
SP-M :Set point during SP ramp	Set point lower limit to Set point upper limit
PV :Process value	Scaling lower limit to scaling upper limit
O :Manipulated variable(heat)	-5.0 to 105.0%
C-O :Manipulated variable(cool)	0.0 to 105.0%
V-M :Value opening	-10.0 to 110.0%

- Default : SP
- The output ranges of the SP settings, set point or process value when temperature input is selected are the ranges supported by the selected sensor.
- When the heating side manipulated variable or cooling side manipulated variable is selected, the transfer output lower limit in a heating and cooling control becomes 0.0.

12 PROCESS METER K3MA-J



Do not touch any of the terminals while the power is being supplied. Doing so may result in electric shock.

Do not disassemble the product or touch the internal components of the product while the power is being supplied. Doing so may result in electric shock.

Do not allow metal objects or wire cuttings to enter the product. Doing so may result in electric shock, fire, or malfunction.

Perform correct settings for the product according to the control application. Failure to do so may cause unexpected operation, resulting in damage to the product or injury.

Take safety measures, such as installing a separate monitoring system, to ensure safety even if the product fails. Product failure may prevent comparative outputs from being generated, resulting in serious accidents.

Maintain the power supply voltage within the range specified in the specifications.

Maintain the load within the ratings specified in the specifications.

Check each terminal for correct number and polarity before connecting it. Incorrect or reverse connections may damage or burn out internal components in the product.

Tighten the terminal screws securely. The recommended tightening torque is 0.43 to 0.58 Nm. Loose screws may cause fire or malfunction.

Do not connect anything to unused terminals.

Provide a switch or circuit breaker so that operators can easily turn OFF the power supply when necessary. Also provide appropriate indications of such devices.

Do not attempt to disassemble, repair, or modify the product.

Do not use the product where flammable or combustible gases are present.

Do not use the product in the following locations:

- **Locations subject to direct radiant heat from heating equipment.**
- **Locations subject to exposure to water, oil, or chemicals.**
- **Locations subject to direct sunlight.**
- **Locations subject to dust or corrosive gases (particularly sulfuric gas or ammonia gas).**
- **Locations subject to severe changes in temperature.**
- **Locations subject to icing or condensation.**
- **Locations subject to shock or vibration.**

Do not block heat dissipation around the product, i.e., provide sufficient space for heat dissipation.

Ensure that the rated voltage is reached within two seconds after the power is turned ON.

Conduct aging for 15 minutes min. after power is turned ON for correct measurement.

Do not touch the slit sections or terminals while the power is being supplied to prevent the product from being affected by static electricity.

Do not lay heavy objects on the product during use or storage. Doing so may deform or deteriorate the product.

Do not use paint thinner for cleaning. Use commercially available alcohol.

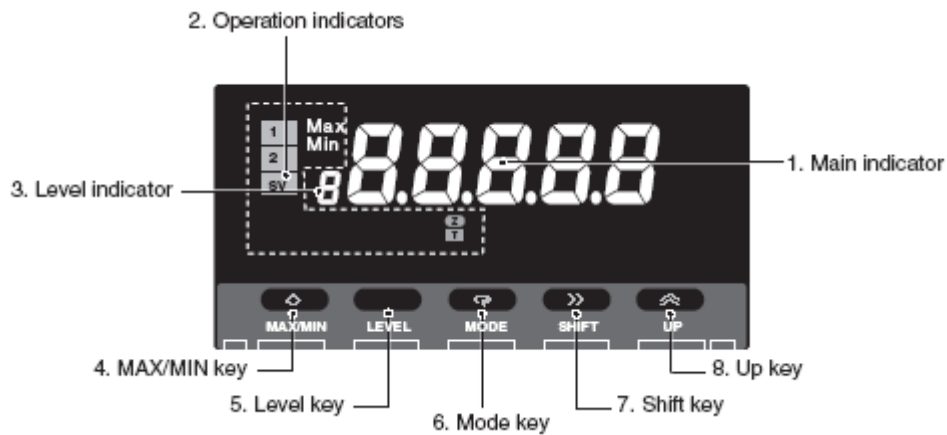

Name	Functions	
1. Main indicator	Displays current values, parameters, and set values.	
2. Operation indicators	1	Lit when output 1 is ON.
	2	Lit when output 2 is ON.
	SV	Lit when a set value is being displayed or changed.
	Max	Lit when the main indicator is showing the MAX value.
	Min	Lit when the main indicator is showing the MIN value.
	Z	Lit during the forced-zero operation.
	T	Lit when the teaching function is operable. Blinks while the teaching function is operating.
3. Level indicator	Displays the current level that the K3MA-J is in. (See below for details.)	
4. MAX/MIN Key	Used to display the MAX and MIN values when a measurement value is being displayed.	
5. level Key	Used to change the level.	
6. Mode Key	Used to allow the main indicator to indicate parameters sequentially.	
7. Shift Key	Used to enable a set value to be changed. When changing a set value, this key is used to move along the digits.	
8. Up Key	Used to change a set value. Used to set or clear a forced-zero function when a measurement value is being displayed.	

Level indicator	Level
p	Protect
Not lit	Operation
s	Initial setting
f	Advanced function setting

12.1 Operation

12.1.1 Levels

Parameters are grouped into levels. The following table lists the operations that are possible in each of the levels, and the diagram tells how to move between levels. There are some parameters that are not displayed for certain models.

Level name	Function	Measurement
Protect	Setting lockouts.	Continue
Operation	Displaying current values, setting/clearing forced-zero function, and setting OUT 1/2 values.	Continue
Initial setting	Making initial settings of input type, scaling, output operating action, and other parameters.	Stopped
Advanced-function setting	Setting average processing, display color settings, and other advanced- function parameters.	Stopped

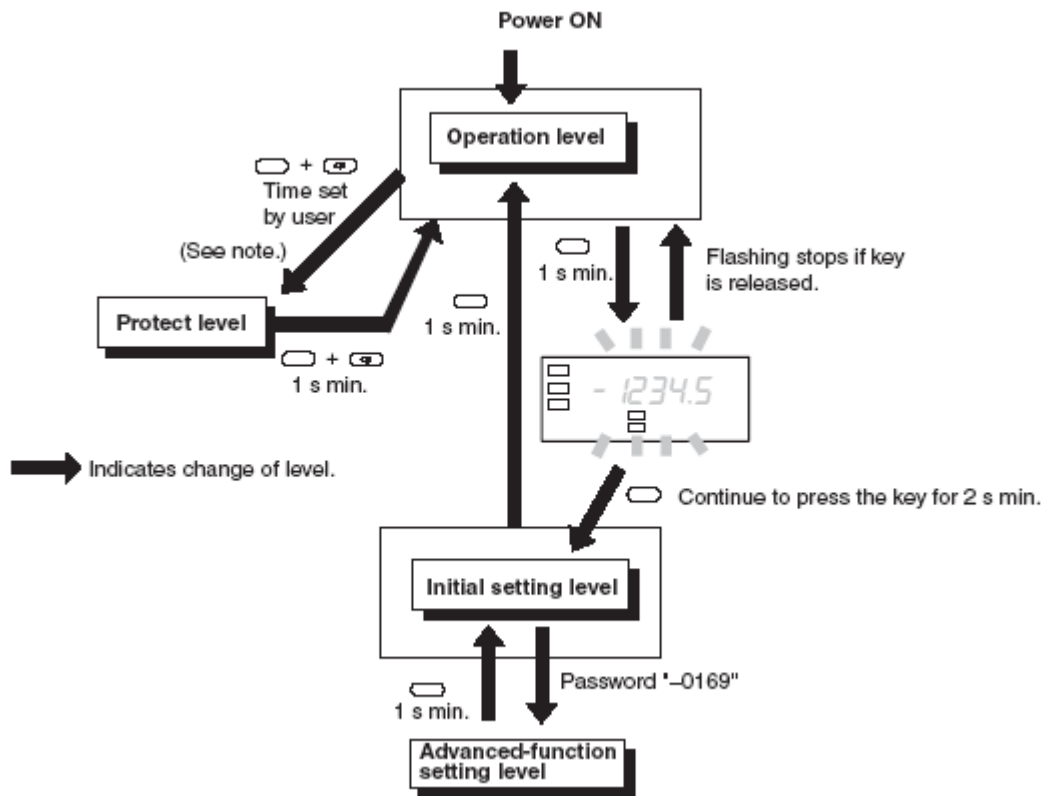

NOTE: The move-to-protect-level can be set in the advanced-function setting level.

12.1.2 Parameters

1. Some parameters are not displayed for certain models.
2. The K3MA-J will stop measurement if the level is changed to the initial setting level or the advanced-function setting level.
3. If the input range is changed, some parameters are set to default values. Therefore, set the input range first.
4. Settings displayed in reversed colors are defaults.

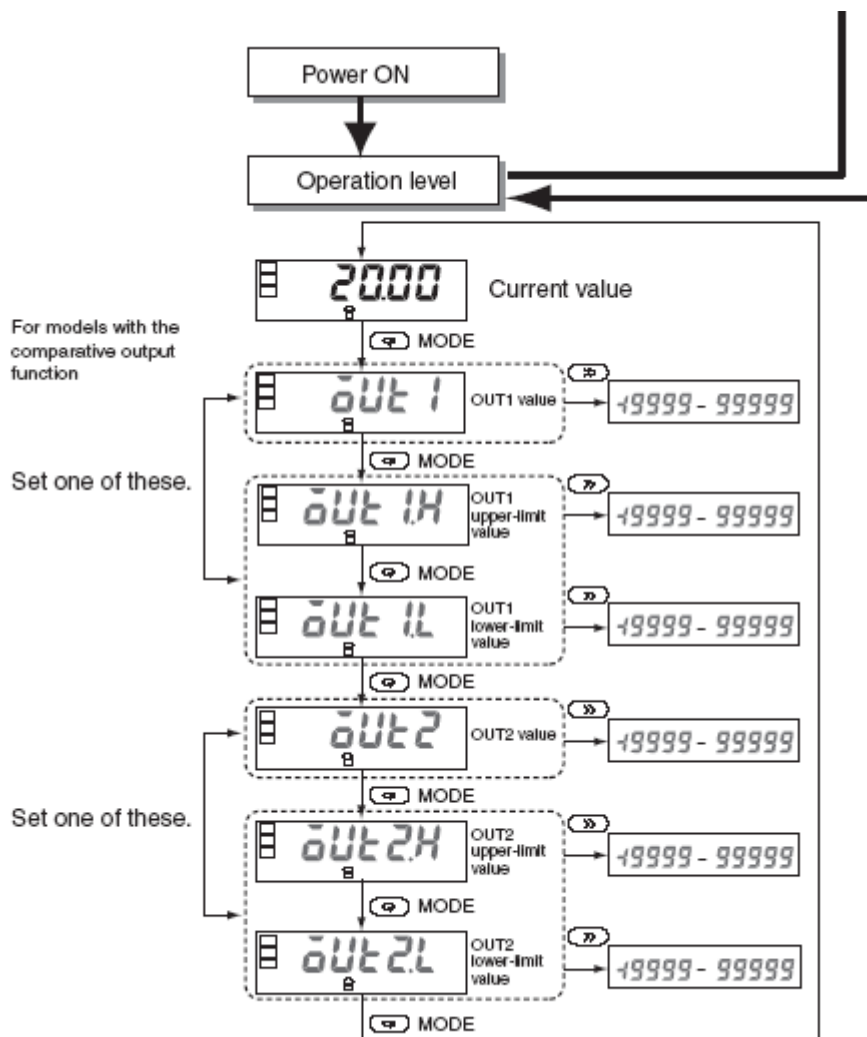

Lockouts

1. Operation and adjustment lockouts

Restricts key operations for operation level and adjustment level.
The initial setting is 0.

This cannot be displayed on models not equipped with the comparative output function.

Parameter	Setting	Operation level	
		Current value display	Set value display
oapt	0	Allowed	Allowed
	1	Allowed	Allowed
	2	Allowed	Prohibited

2. Setting level lockout

Restricts shifting to initial setting level or advanced-function setting level.

Parameter	Setting	Shift to initial setting level	Shift to advanced-function setting level
icpt	0	Allowed	Allowed
	1	Allowed	Prohibited
	2	Prohibited	Prohibited

3. Setting change lockout

Restricts setting changes by key operation. When this lockout is set, it is no longer possible to shift to a setting change mode.
However, all protect level parameters can still be changed.

Parameter	Setting	Setting change by key operation
wtpt	Off	Allowed
	On	Prohibited

4. Forced-zero lockout

Restricts the setting or release of a forced-zero by front-panel key operation.

Parameter	Setting	Setting/release of forced-zero by key operation
=rpt	Off	Allowed
	On	Prohibited

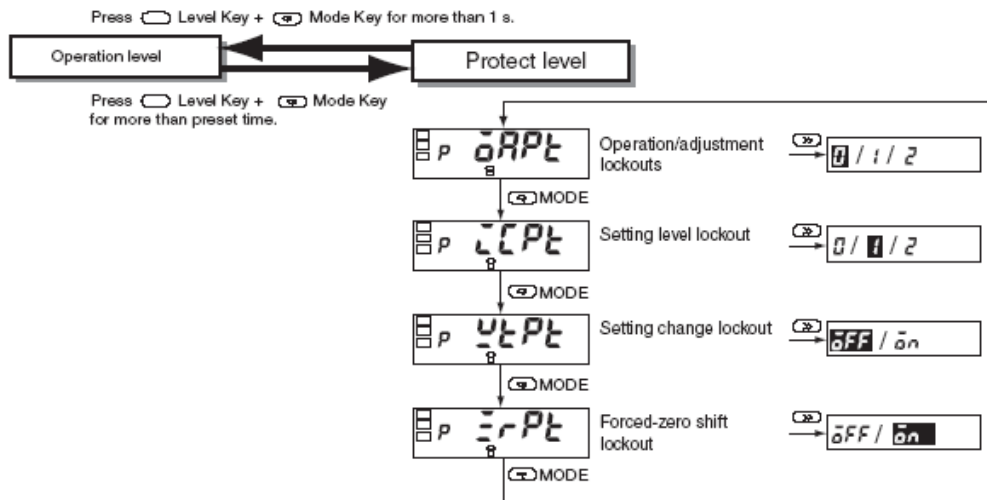

12.2 Troubleshooting

When an error occurs, error details will be displayed on the main indicator. Confirm the error from the main indicator and take the appropriate countermeasures.

Level display	Main indicator	Error contents	Countermeasures
Not lit	E111	RAM memory error	Repair is necessary. Consult Auramarine Ltd.
5	E111	EEPROM memory error	When this error is displayed, press the Level Key for 3 seconds, and the settings will be restored to the factory settings. If the error cannot be recovered, repair is necessary. Consult Auramarine Ltd.
Not lit	Flashes <i>5.Err</i>	You will see this indication when turning ON the product the first time after purchase. This is because the input signal value is 0 mA at that time even though the range is factory set to 4 to 20 mA.	At the initial setting level, set the input type and other parameters according to your application.
		Input error	Promptly change the input voltage/current to a value that falls within the measurement range. If the error cannot be recovered, repair is necessary. Consult Auramarine Ltd.
Not lit	Flashes <i>99999</i>	The scaling display value exceeds 99999.	Promptly change the input to a value that falls within the specified range.
			The scaling value may be inappropriate. Review the scaling value at the initial setting level.
Not lit	Flashes <i>-19999</i>	The scaling display value is lower than -19999.	Promptly change the input to a value that falls within the specified range.
			The scaling value may be inappropriate. Review the scaling value at the initial setting level.

13 RESISTANCE THERMOMETER, MODELS PT COMPACT AND PT COMPACT PLUS

Models CP11, CS11, CS12, CS13, CS14, CS71

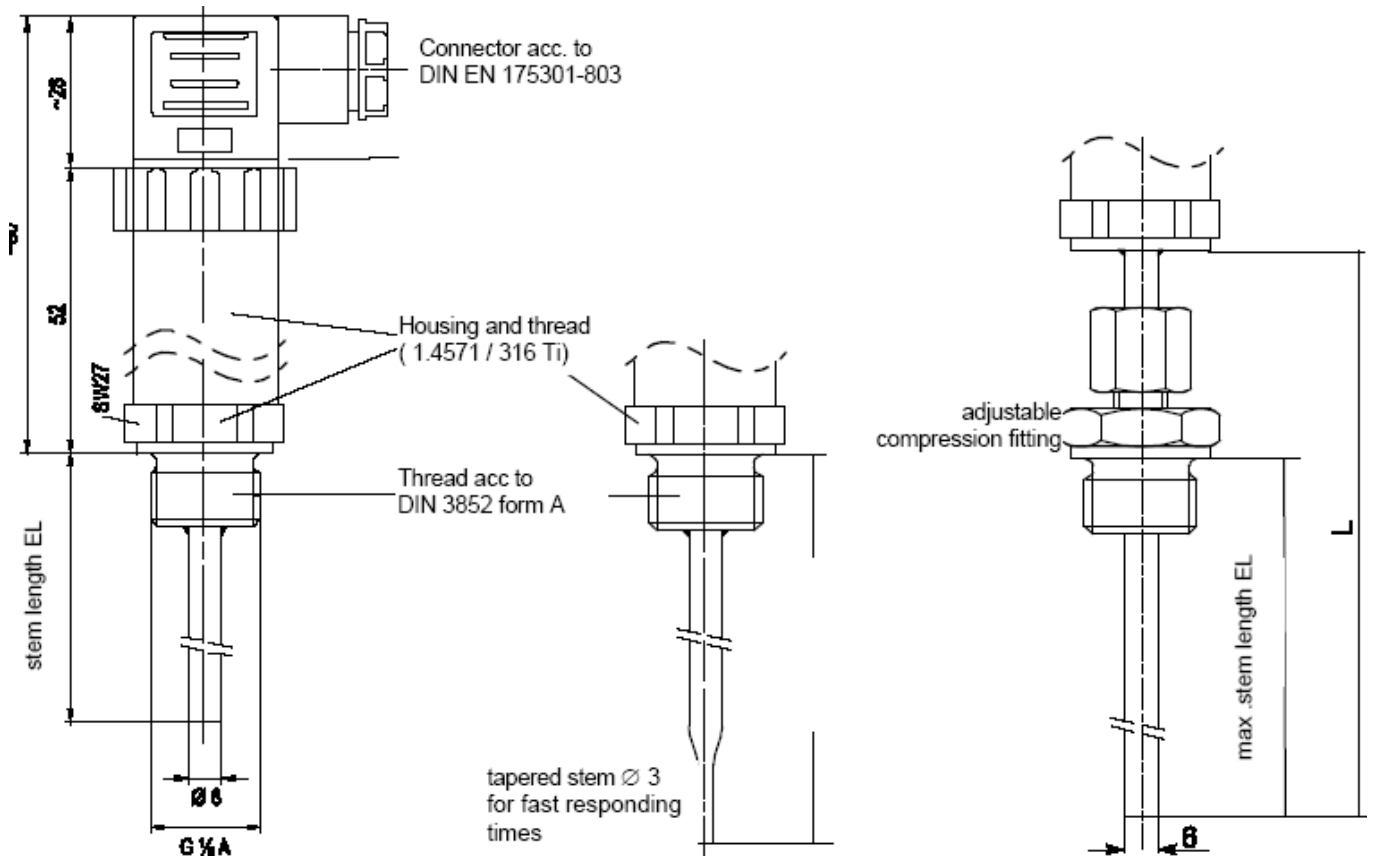

Wiring diagrams

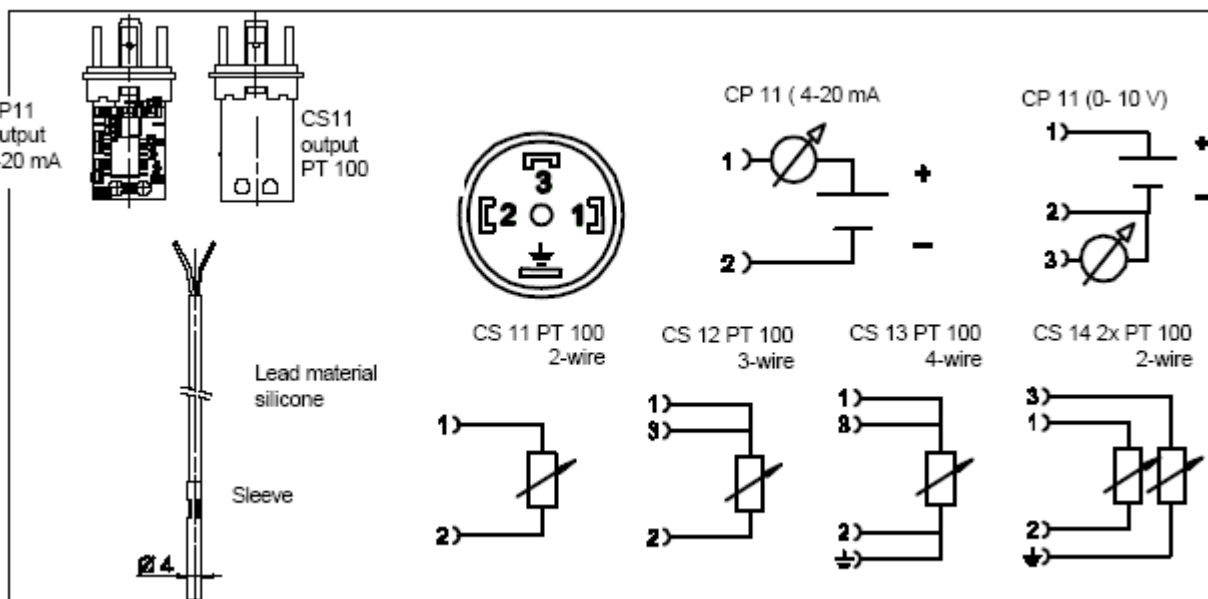

14 PRESSURE SWITCH MBC 5000, 5100

Electrical connection

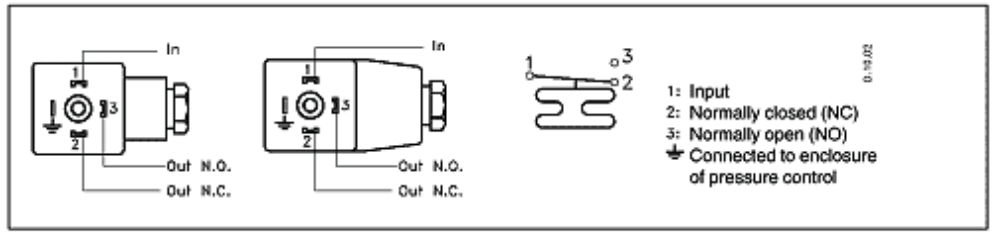

Mechanical connection

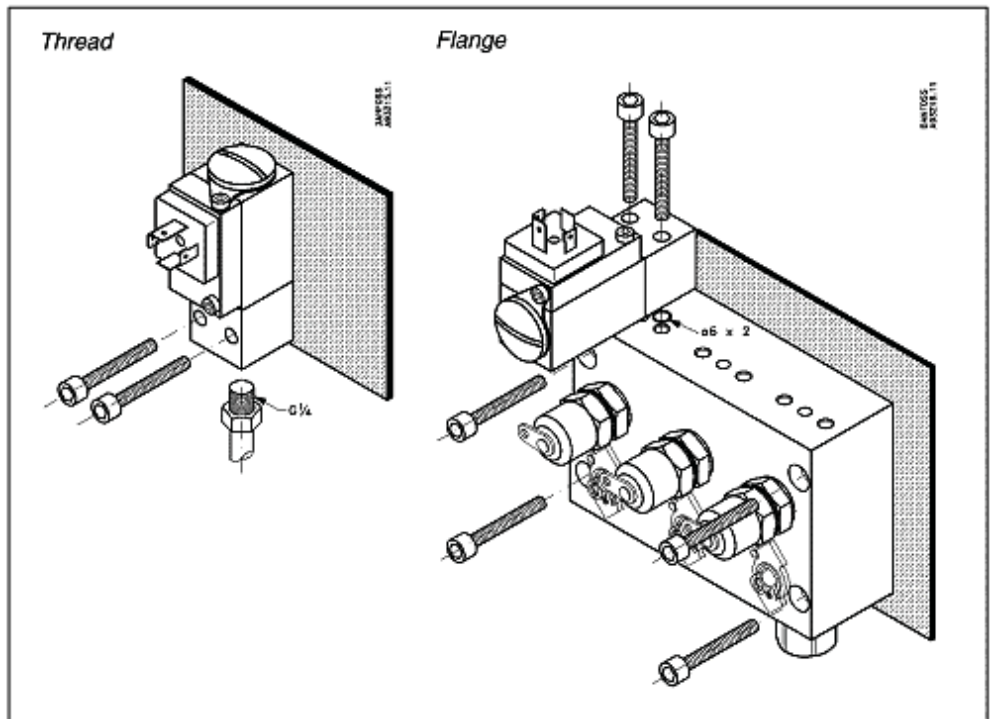

Adjustment

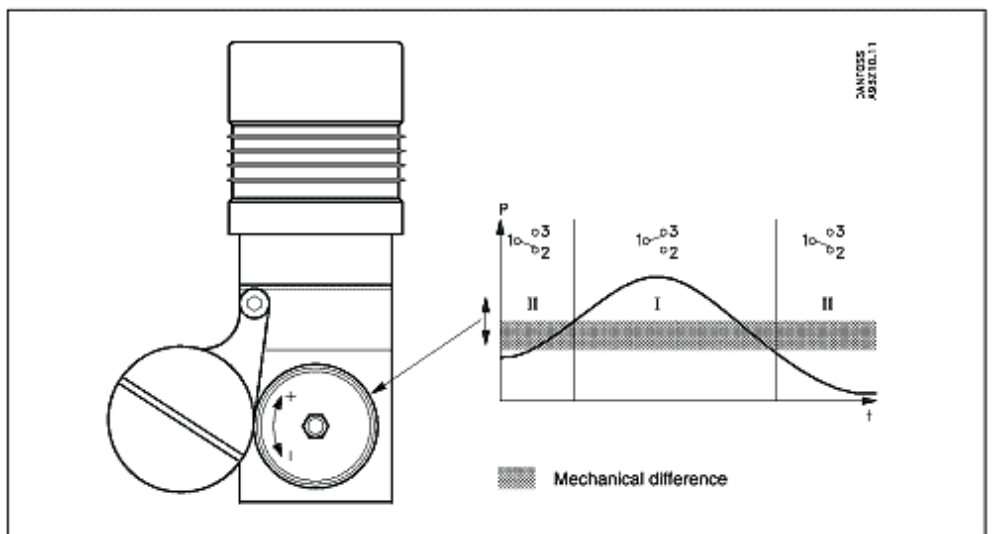

15 LEVEL LIMIT SWITCH LIQUIPHANT T FTL20



The device may be installed, connected, commissioned, operated and maintained by qualified and authorised personnel only.

Do not bend.

Do not shorten.

Do not lengthen.

15.1 Instructions

1. Handling

Hold by the housing, not by the sensor fork

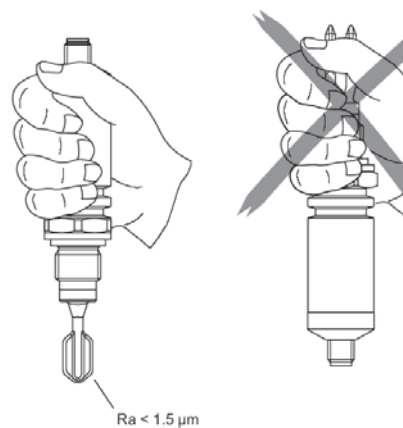

2. Take account of viscosity and build-up

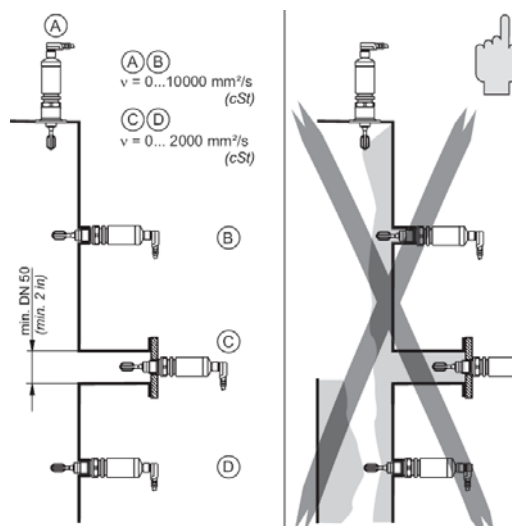

3. Align sensor fork Note mark ▼

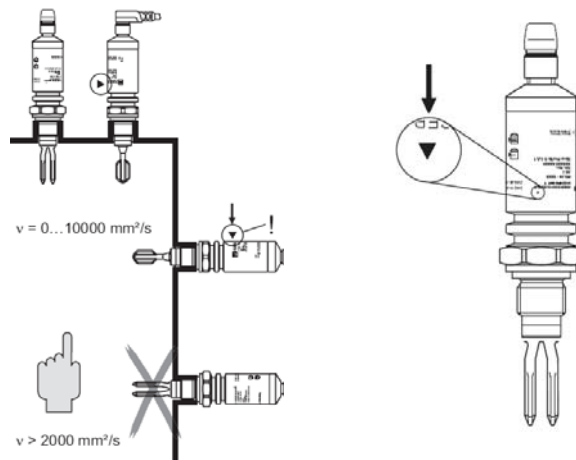

4. Test with test magnet

 MAX	1. gn ye → 2. gn ye
 MIN	1. gn ye → 2. gn ye
 MAX MIN	1. gn rd → 2. gn rd

5. Cleaning



16 VISCOSITY SENSOR, TYPE VISCOSENSE2



Always use personal protective means when working with hot, aggressive and toxic process liquids.

Always use insulated tools when working on electrical installations.

The ViscoSense2 sensor body will heat up to the process temperature; do not touch instrument while process is running.

Never try to open the back of the sensor. This will damage the wire and sensor .

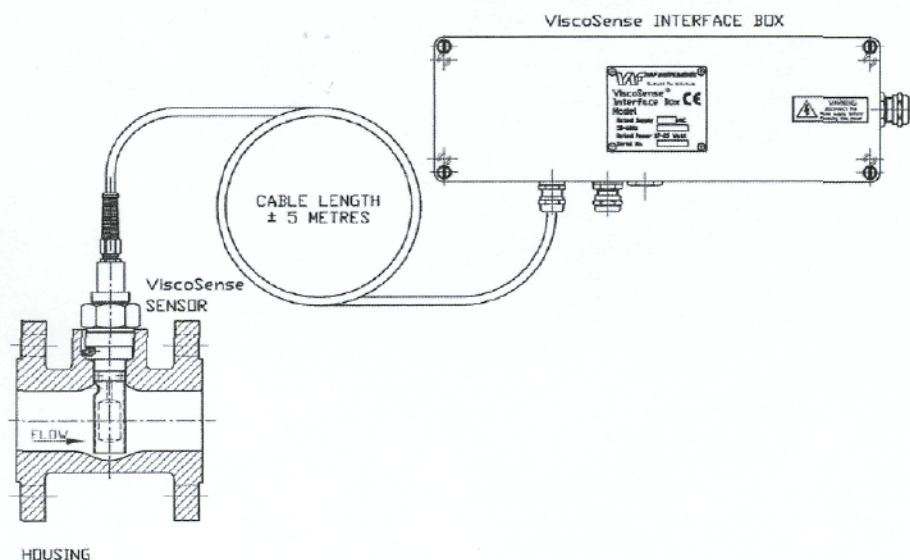

Fig 1 ViscoSense2 components

The sensor housing is made of ductile iron and has flanges for direct mounting in the fuel line. The sensor itself is made of stainless steel and is mounted in the housing. Two parts of the sensor, the pendulum and flowtube have a special teflon coating. It is supplied with 5 metres of signal cable for connection to the interface box.

The ViscoSense2 Interface box is a wall mount electronic unit, processing the signals from and to the sensor. It provides 4..20 mA signals for remote read-out of viscosity and temperature for a controller or other system elements.

The operating principle of the sensor is that of a torsion pendulum. The sensor consists of a stainless steel driver / sensor head (1), attached to the base plate (2) by means of a tubular torsion spring (3). In the head, one pair of piezo elements (driver piezos) (4) actuates the pendulum at its torsional resonance frequency, while another pair (the receiver piezos) probe the actual movement of the head. In a low viscosity medium, like air the resonance frequency is in the range of 1600 Hz. In a high viscosity medium the movement of the head is damped by the liquid. Consequently, the resonance frequency slightly shifts towards lower frequencies, whilst the width of the resonance peak increases, which is a measure for the viscosity. A flow tube (5) is placed around the pendulum, to protect it against mechanical damage. The flowtube inlet ensures a constant new supply of liquid for a correct measurement.

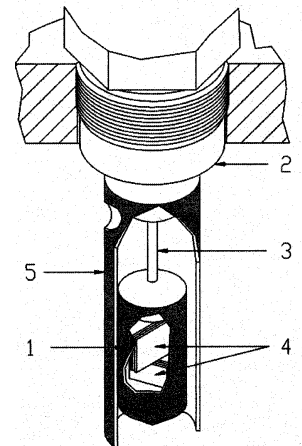

Fig 2 ViscoSense2 sensor

16.1 Operation

16.1.1 Initial start-up

1. Fill complete fuel system with diesel oil.
2. Open block valves (K and M) and bypass valve (L)
3. Allow diesel oil to enter the fuel system
4. Vent the fuel system.
5. Start the booster pump in the fuel system and after app 15 minutes close bypass valve (L)
6. Switch on power supply to the ViscoSense2 system.
Depending upon the viscosity of the liquid, it can take up to 30 seconds before the first reading appears. This is due to the automatic signal gain control.
7. Gradually change over to HFO.

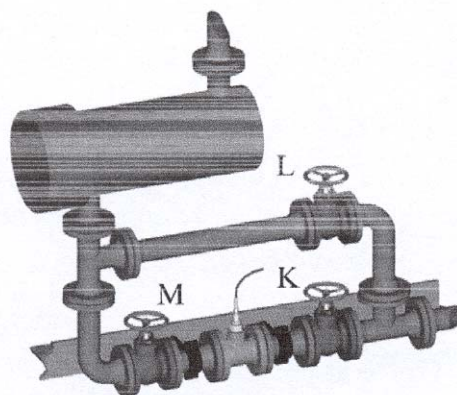

Fig 3

16.1.2 Routine start-up

Make sure that the power is on. No other special actions on the ViscoSense22 unit are required.

16.1.3 Shutdown on diesel oil

No special actions on the ViscoSense2 unit are required.

16.1.4 Shutdown on heavy fuel oil

Maintain heat tracing on the ViscoSense2 sensor housing after shutdown to prevent clogging of the fuel to the sensor internal parts.

16.2 Maintenance

16.2.1 Routine maintenance

Under normal conditions, the ViscoSense2 sensor requires no maintenance. "Normal" means;

- A clean operating environment
- ViscoSense2 interface box installed in accordance with the installation instructions given
- Operation accordance with manual
- Uninterrupted power supply at normal specified values

The flow should be in-between the maximum and minimum fluid flow rate. The ViscoSense2 housing should be placed in such a way, that no air can be trapped in the housing.

The fluid should be homogenous. It should not contain any air bubbles or foam. The fluid should not contain any chemicals or solid particals, that can damage teflon.

The ViscoSense2 sensor and interface box cannot be repaired onsite. They will be either exchanged for a spare unit or sent back to the manufacturer.

16.2.2 Cleaning



When removing the ViscoSense2 sensor from the piping system, precautions must be taken to prevent personal injuries and damage to the sensor and process installation.

General procedure

1. Change over to manual viscosity control
2. Shut off flow through the ViscoSense2 sensor by closing the valves on both sides of the sensor housing.
3. Switch off power supply to the ViscoSense2 interface box.
4. If possible, drain and empty the piping system.



Although the flow has been shut off, the ViscoSense2 sensor can still be hot and under pressure. Be careful when loosening flange bolts.

If the sensor is removed from a sensor housing which has not been de-pressurized, hot oil will spray out.

5. Unscrew the ViscoSense2 sensor from its housing by loosening nut (1, fig 4).
6. Take out the ViscoSense2 sensor.
7. **DO NOT REMOVE THE FLOW TUBE, DO NOT STICK ANY OBJECTS IN BETWEEN THE FLOW TUBE AND PENDULUM.**
8. Flush the space between the tube and the pendulum with diesel oil or non aggressive cleaning detergent.



Take care that the pendulum is not damaged or bent by mechanical force.

Do not use abrasive materials like sandpaper, files, etc. to clean the flow tube. This will damage the teflon coating.

16.2.2.1 Sensor assembly

1. Check the O-ring (2) before installing the ViscoSense2 sensor. Replace if necessary.

NOTE: Make sure not to damage the teflon coating during installation.

2. Carefully insert the ViscoSense2 sensor into the housing with the flow tube inlet facing the flow.

NOTE: Make sure the flow tube inlet is pointing towards the inlet of the sensor housing. If installed wrong, the sensor will not work correctly.

Check if the position of the hole inside the housing and the fixation pin on the sensor match.

3. Tighten the nut (1) by hand. If there is a temperature difference between the sensor and the housing, wait until they have the same temperature before tightening the nut.
4. Tighten the nut (1) with a wrench. Recommended torque is 100 Nm.



Make sure that all bolts and screws are tightened correctly before re-pressurising the system.

5. The ViscoSense2 system is now ready for operation.

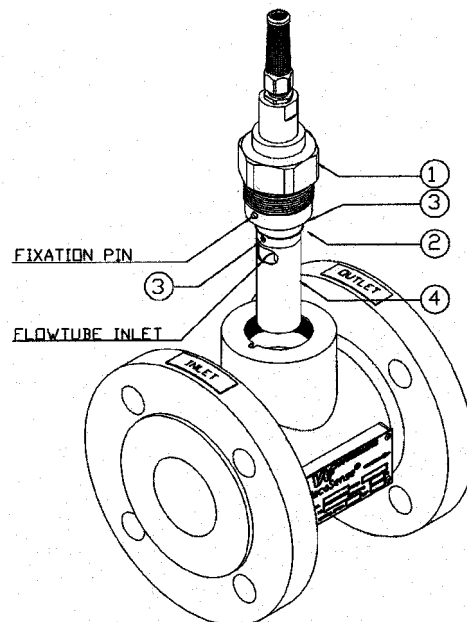
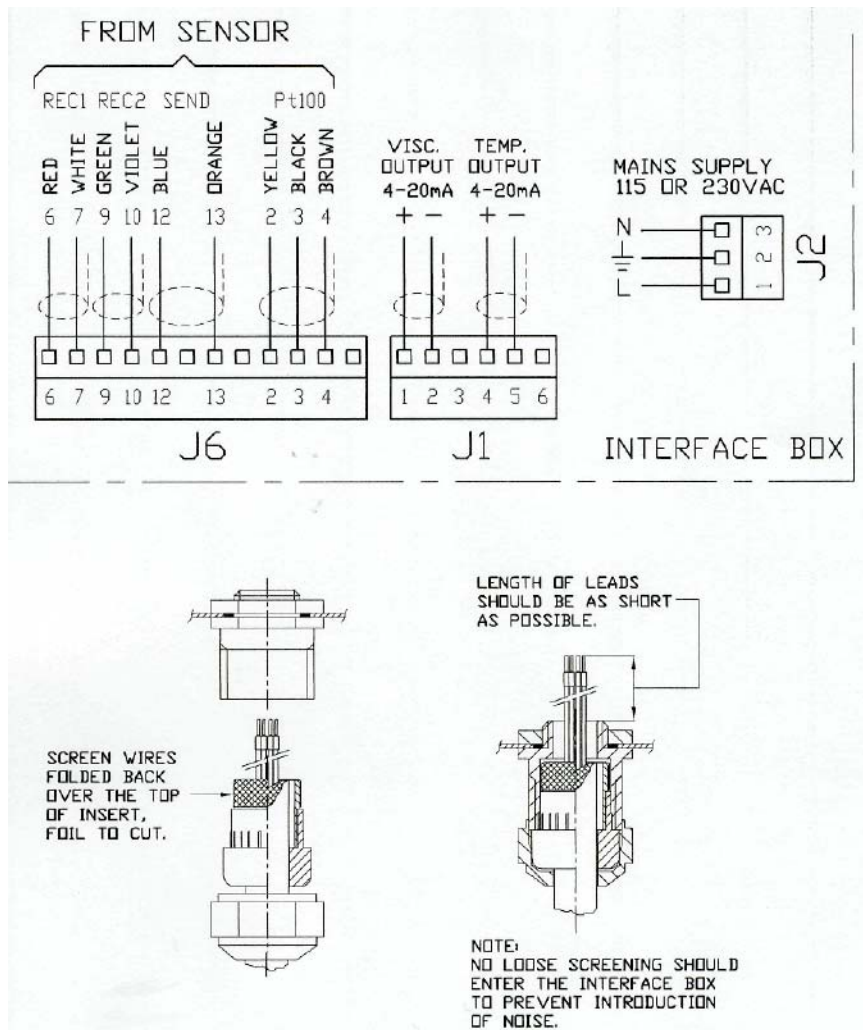

Fig 4 ViscoSense2 sensor assembly

16.3 Electrical connections



16.4 Trouble shooting and repair







The ViscoSense2 sensor and interface box cannot be repaired onsite. They will be either exchanged for a spare unit or sent back to the manufacturer.

When taking the interface box out of service, disconnect power to the box. The ViscoSense2 sensor should be taken out of the sensor housing and cleaned. To protect the pendulum from damage due to mechanical shocks, the transport locking cap should be carefully placed in between the flow tube and the pendulum. The sensor must be wrapped in protection material to protect it from damage. Both the sensor and the interface box must be stored in a cool and dry place.

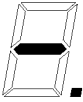
16.4.1 Diagnostic information

The printed circuit board inside the ViscoSense2 controller has a provision for diagnostic indication. Failures and errors are displayed by a blinking digit or character on a 7 segment LED. Dependent on the type of failure, error or warning, the viscosity and/or temperature outputs will go to 0, 4 or 20 mA, or will remain functioning normally.

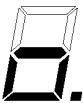
If there is no failure, error or warning, the display indicates the state of the program by displaying a symbol (not blinking) on the display. The following symbols are displayed during normal operation:

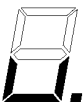
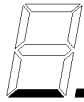
Disp lay	Description	Dis pla y	Description
	Power on		Changing U-send setpoint
	Initialising hardware		Measuring at +45° (Left -3 dB point)
	VCO frequency measurement while phase is +45°		Measuring at -45° (Left +3 dB point)
	Waiting for U_receive to settle after changing setpoint		Adjusting phase

The decimal point at the bottom of the display is always on after power is on. This point is only turned off while the ViscoSense2 is writing to EEPROM and if no measurement is possible due to extensive external vibrations.





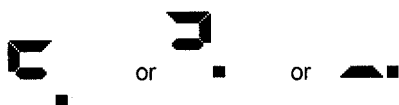

Normally the ViscoSense2 electronics will try to restart the unit if a faulty situation occurs. However, if the fault is persistent, contact Auramarine Ltd and give a detailed description of the problem that occurred and the diagnostic information indicated at the 7 Segment LED.

The faults indicated in the table below are listed in order of priority. The faults on top of the list have the highest priority. This means that faults with a lower priority can be overwritten by faults of a higher priority.

At power-on the system is explicitly tested for failures indicated by display messages 1, 2, 3, 4, 5, 6 and 7. During normal operation these tests (except 2) run at the background.



followed by

Display message	Viscosity output mA	Temperature output mA	Recovery action	Fault description
	0	0	Delay & retry	15 V power failure. Supply drops below 13 V
	0	Actual	Delay & retry	Pendulum not oscillating
	0	Actual	Delay & retry	Oscillation error
	4 4	20 4	None None	Temperature out of range (overflow) Temperature out of range (underflow)
	20 4	Actual Actual	None None	Viscosity out of range (overflow) Viscosity out of range (underflow)
	Actual Open loop	Open loop Actual	None None	Temperature output open loop Viscosity output open loop
Not all segments working after power on	Actual	Actual	Not applicable	7 - segment display defective

Any other figure or letter indicates an error in the electronics or software.

16.4.2 General trouble shooting

Problem	Possible cause	Corrective action
No viscosity signal	No supply to interface box	Check supply. Check fuses. Check electrical connections.
	Current loop connection broken	Check electrical wiring of 4-20 mA output signal
	Air entrapped in the fuel system	Vent the system
	ViscoSense2 malfunctioning	Check diagnostic led
No temperature signal	No supply to interface box	Check supply. Check fuses. Check electrical connections.
	Current loop connection broken	Check electrical wiring of 4-20 mA output signal
	ViscoSense2 malfunctioning	Check diagnostic led
Viscosity output is lower than expected	Actual viscosity is lower than expected. E.g. bunker calculator only gives approx. value. Dilution with MDO. Temperature is higher than expected.	None (For laboratory check of viscosity).
	Range settings ViscoSense2 and readout unit do not match	Check mA signal and range settings
	Air entrapped in the fuel system	Vent the system
Viscosity output is higher than expected	Actual viscosity is higher than expected. E.g. bunker calculator only gives approx. value. Temperature is lower than expected.	None (For laboratory check of viscosity).
	Range settings ViscoSense2 and readout unit do not match	Check mA signal and range settings
	Fuel is not pure, well mixed liquid	Vent the system
	Sensor is damaged or fouled	Clean and inspect the sensor

Viscosity output is max range	The viscosity in the sensor housing is higher than the max range	Heat up the fluid
	Actual viscosity is higher than expected. E.g. bunker calculator only gives app value	None
	ViscoSense2 interface box is malfunctioning	Check diagnostic led
	ViscoSense2 sensor is malfunctioning	
	Range settings ViscoSense2 and readout unit do not match	Check mA signal and range settings
	Sensor is damaged or fouled	Clean and inspect the sensor

16.4.3 PI setting errors (for additional viscosity controller)

The heater in the booster system are controlled by a viscosity controller. In order to get a good working viscosity system an optimum adaptation of the control parameters (P=proportional band Pb %), I=integral action time Ti min) is necessary.

Problem	Possible cause	Corrective action
Oscillating temperature with distinct initial overshoot	Pb too low	Increase Pb
Set point is reached very slowly after initial exceeding	Pb too high	Decrease Pb
The set value is reached very slowly without overshooting	Ti too high	Decrease Ti
High initial overshoot followed by fading oscillation	Ti too low	Increase Ti

16.5 Parts lists

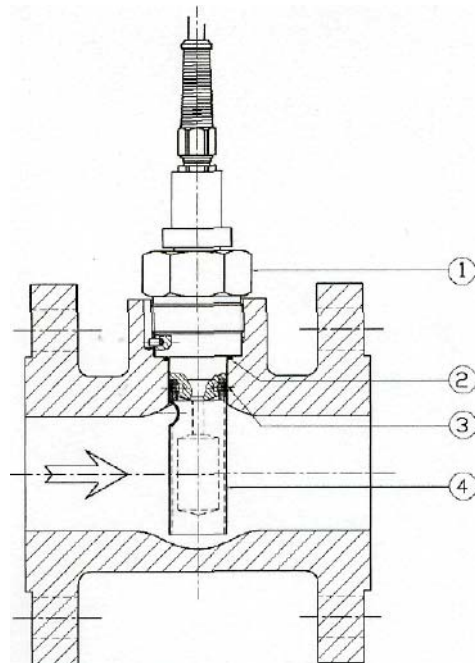

Ref. No	Qty	Part Number	Description & Material
1	1	0279-0096	ViscoSense2 sensor
2	1	0630-3022	O-ring, ID 25.12xØ 1.78mm
3	2	1743-0404	Hex. socket set screw M4x4 mm, DIN916
4	1	0342-0027	Flow tube

17 FLOW METER, TYPE VZF



Before working on the hydraulics, put the plant or section out of operation, close the stop valves and release the pressure

Comply with the permissible operating data as defined on the type plate. Pressure test with a maximum of 1.5 x the nominal pressure (PN).

Make sure that no hazardous fumes can build up in the piping and in the meter during commissioning, decommissioning and dismantling.

The meter must at all times be completely filled with liquid during operation.

Check the meter periodically for tightness of the connections and for proper functioning.

If work is to be done on the installation, before each intervention:

- **release the pressure in the installation**
- **if hazardous liquids are used, wear protective clothing and safety goggles**
- **place a collecting tray underneath the installation.**

When restarting the plant:

- **slowly open the stop valves, avoiding pressure surges ('water hammer')**
- **vent the pipe well**
- **check tightness**

17.1 Display

All data are saved periodically, and every time a key is pressed, in a non-volatile memory (EEPROM). This means that the last value is saved even if the power supply is interrupted.

The 7-segment display can show 8-digit measured values with a decimal point or text messages using letters in a special presentation mode. Units of measurement and additional items of information are shown with symbols or index indicators. The references to these in the text are shown in square brackets, e.g. [LIMIT MAX].

The display data and parameters are split into three menu groups:

- a) Main Menu: displays measured data, accesses other menus, tests display segments and displays error messages (if present).
- b) Information Menu: displays additional information about the meter and operating status
- c) Parameter Menu: displays parameter settings for the display and output signals. To set these parameters, the device must be unlocked with the Service key. This is located in the connections compartment and is only accessible after the display module has been opened or unscrewed.

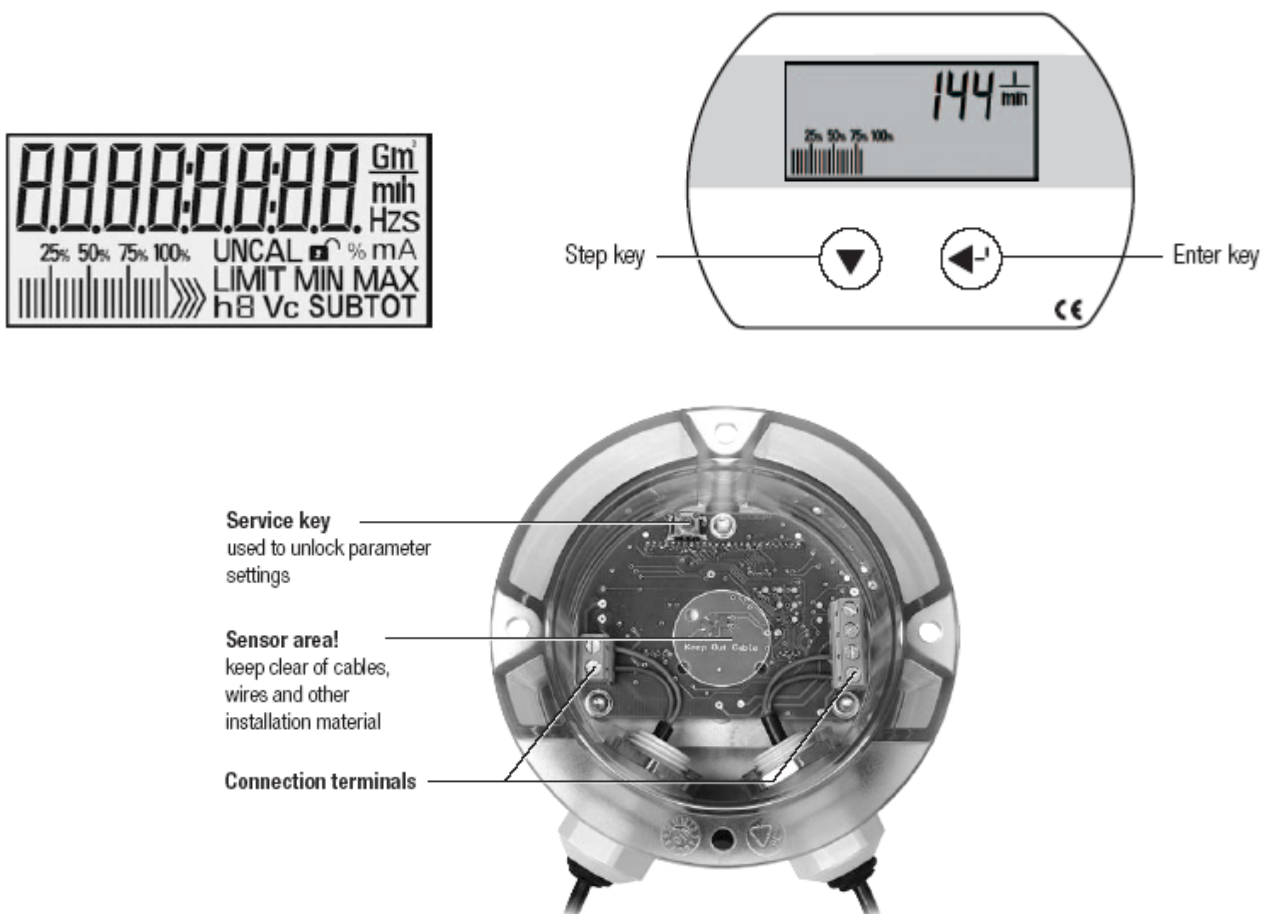

17.2 Operation

17.2.1 Main menu

The standard display of the Main Menu is the total volume. Use the Step key to go to the measured value for the resettable volume or the flow rate and other menu items, as follows:

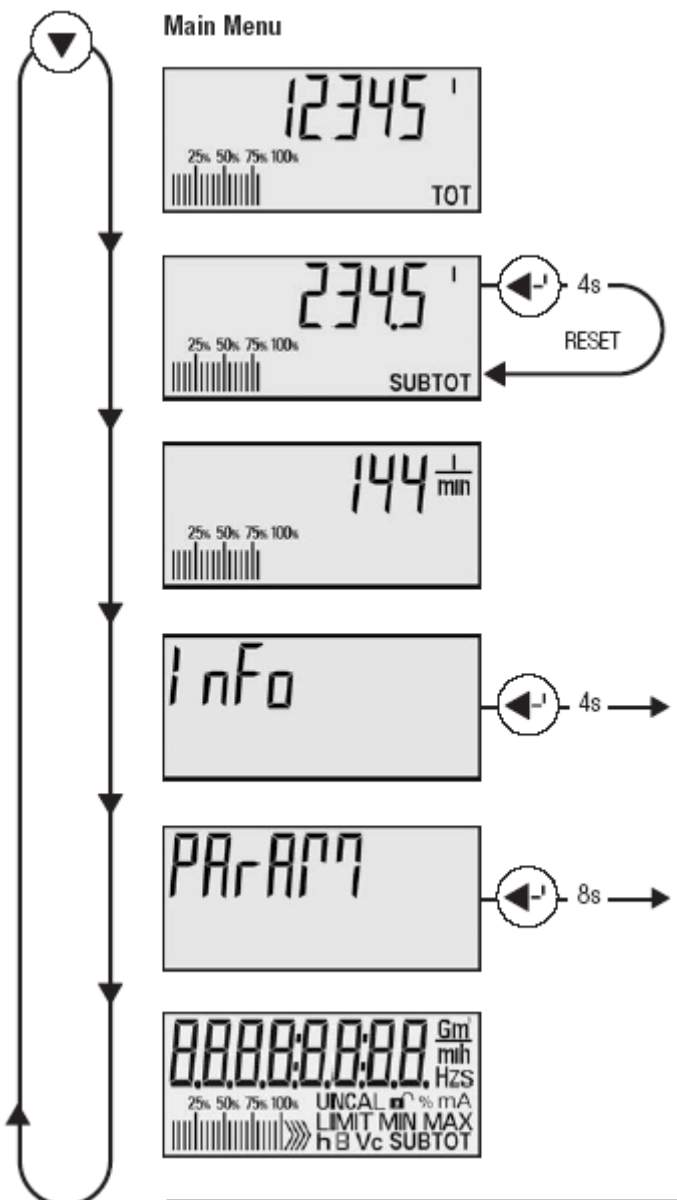

Total volume [TOT] cannot be reset
Standard display adopted by the meter after a time-out. The flow indicator bar corresponds to the meter measuring range. It shows the flow rate by means of graduation marks, in steps of 5 per cent up to Qmax.

Subtotal volume [SUBTOT] can be reset
Reset: press the Enter key for 4 seconds. Reset must be enabled in the Parameter Menu. The flow indicator bar corresponds to the meter measuring range. It shows the flow rate by means of graduation marks, in steps of 5 per cent up to Qmax.

Current flow rate
Besides being displayed numerically, this value is also shown in the display by a bar with graduation marks, each mark representing 5% of the maximum permitted flow rate.

Entry portal for the Information Menu
Display additional information about the device and operating status.
To access: press the Enter key for 4 seconds.
Time-out: 60 seconds

Entry portal for the Parameter Menu
Display and settings for device and operating parameters for display and outputs.
To access: press the Enter key for 8 seconds.
Time-Out: 60 seconds

Display test
All the segments are shown for 2 seconds for monitoring. This test is also performed after switching on the unit.

**Device errors**

If a device error is detected during the periodic self-test, this message is briefly shown on the display every 2 seconds. Measuring accuracy is impaired.



The meter may supply incorrect values. The Information Menu gives more information on the error.

The value displayed in "subtotal volume" [SUBTOT] can be reset to zero by pressing the Enter key for about 4 seconds, unless this function has been disabled in the Parameter Menu.

If a meter error is present, the [ERROR] warning appears on the display every 2 seconds. Details about the error are shown in the Information Menu.

17.2.2 Information menu

Select the [INFO] item from the Main Menu and then press the Enter key for approx.4 seconds to enter the Information Menu. Use the Step key to view the following additional information about the meter and the operating status:

Information Menu

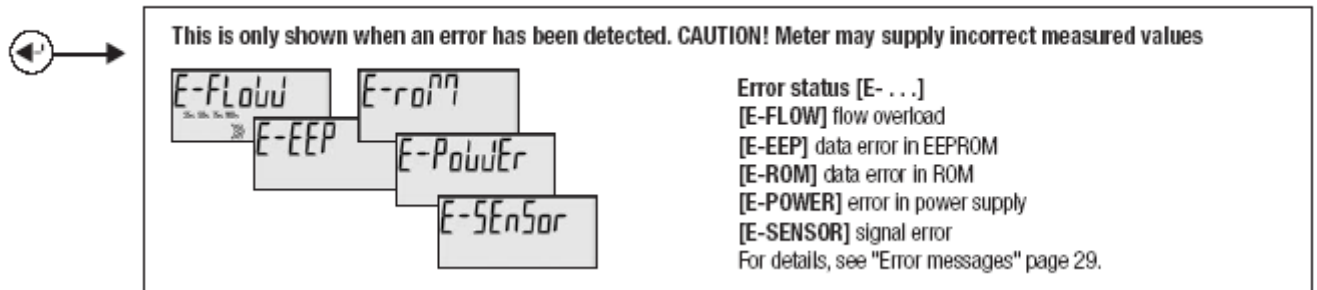







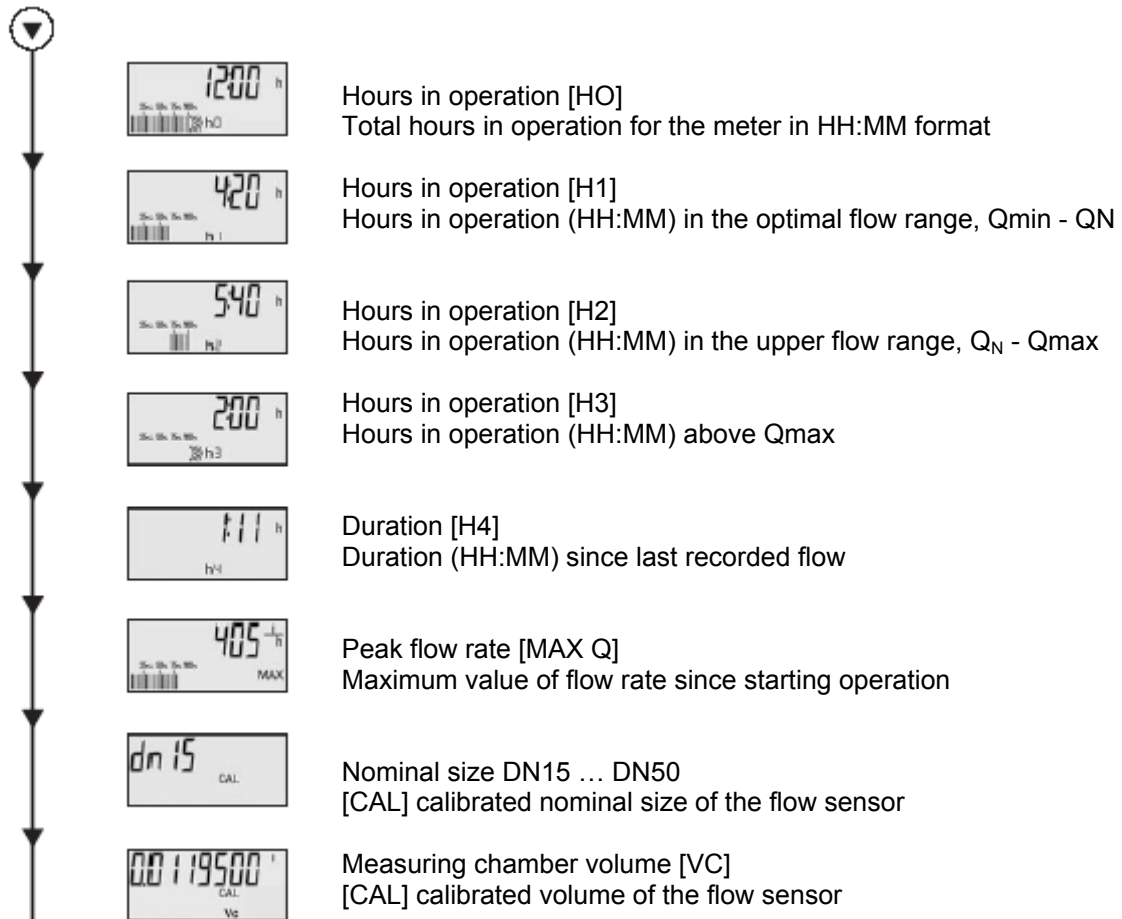

This is only shown when an error has been detected. CAUTION! Meter may supply incorrect measured values

E-Flow E-EEP E-ROM E-Power E-Sensor

Error status [E- . . .]
 [E-FLOW] flow overload
 [E-EEP] data error in EEPROM
 [E-ROM] data error in ROM
 [E-POWER] error in power supply
 [E-SENSOR] signal error
 For details, see "Error messages" page 29.



- 
 Hours in operation [HO]
 Total hours in operation for the meter in HH:MM format
- 
 Hours in operation [H1]
 Hours in operation (HH:MM) in the optimal flow range, Qmin - QN
- 
 Hours in operation [H2]
 Hours in operation (HH:MM) in the upper flow range, Q_N - Qmax
- 
 Hours in operation [H3]
 Hours in operation (HH:MM) above Qmax
- 
 Duration [H4]
 Duration (HH:MM) since last recorded flow
- 
 Peak flow rate [MAX Q]
 Maximum value of flow rate since starting operation
- 
 Nominal size DN15 ... DN50
 [CAL] calibrated nominal size of the flow sensor
- 
 Measuring chamber volume [VC]
 [CAL] calibrated volume of the flow sensor

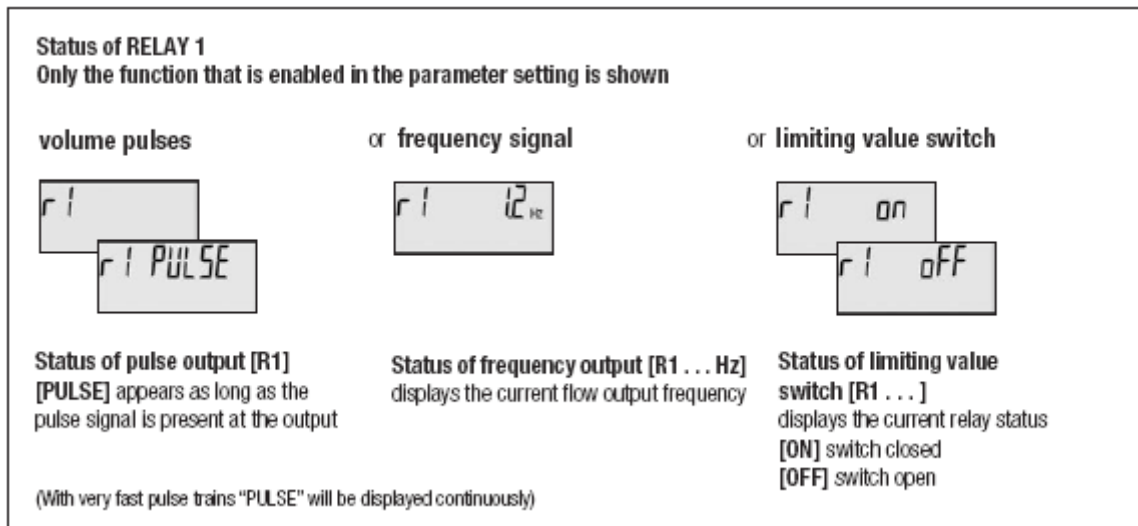
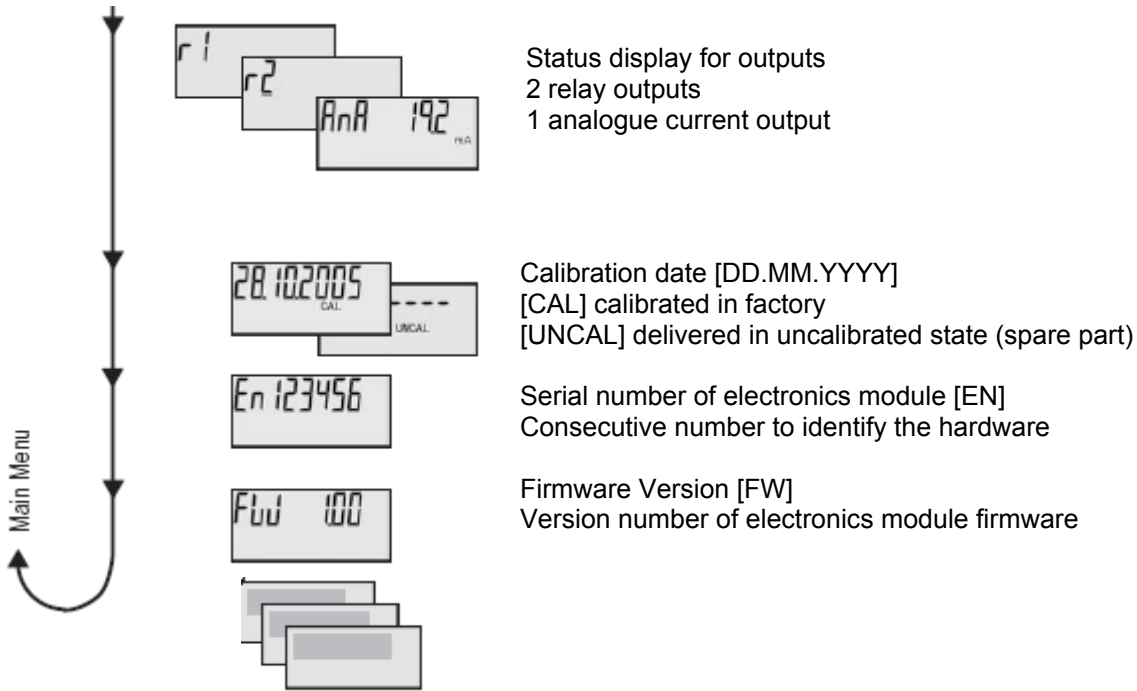

Only the second output enabled in the "Output selection" parameter setting is shown (relay 2 or analog)

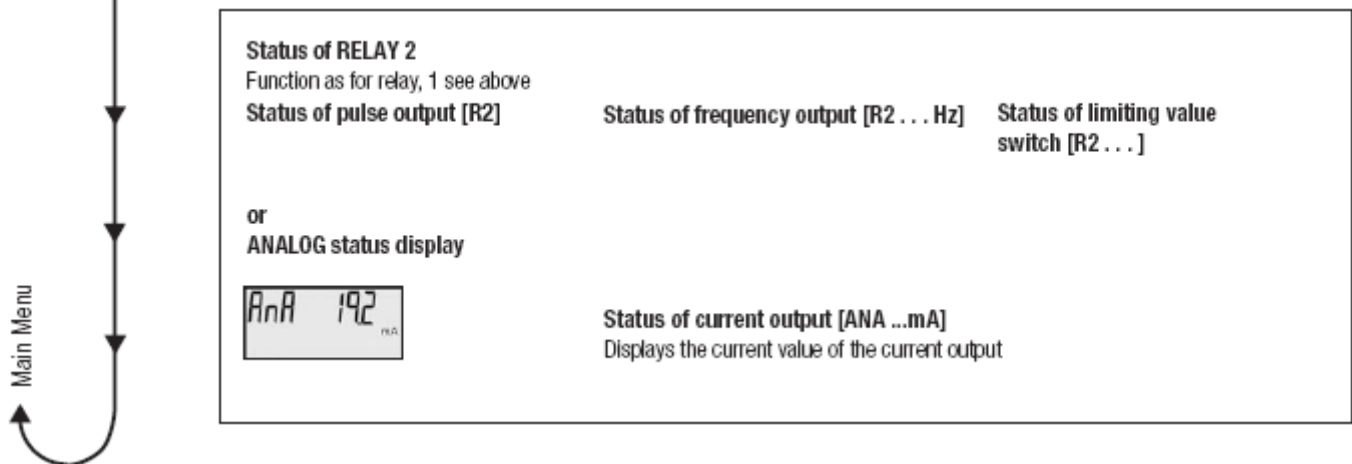



If both keys are pressed at the same time, or if no key is pressed for 60 seconds, the device returns to the standard display.

17.2.3 Parameter menu

Select the [PARAMETER] item from the Main Menu and press the Enter key for approx. 8 seconds to enter the Parameter Menu.

The menu structure for reading out parameters is shown below. Use the Step key to display all the parameters that are set. Submenus are available for the relay and power output menus; to enter them, press the Enter key.

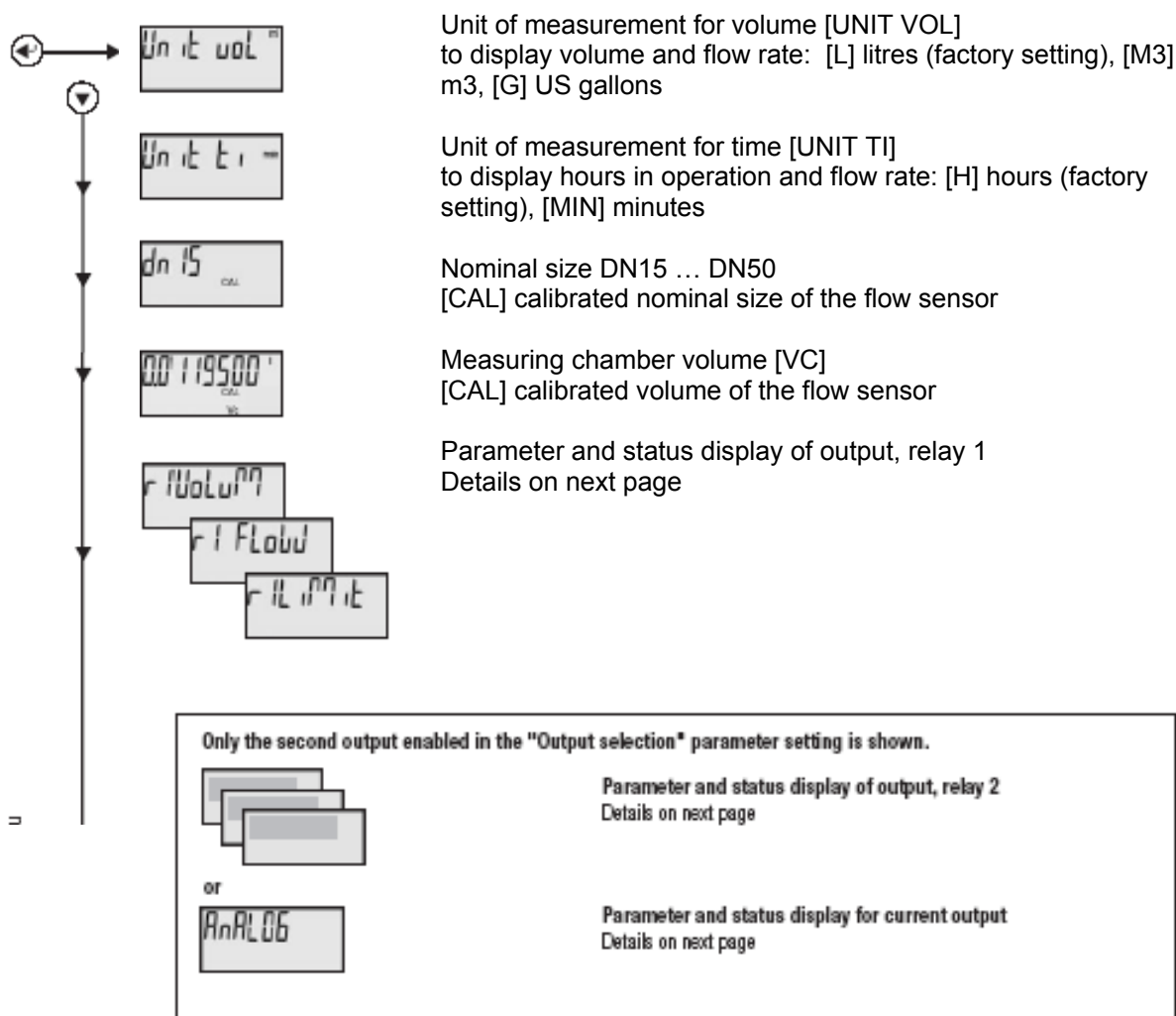





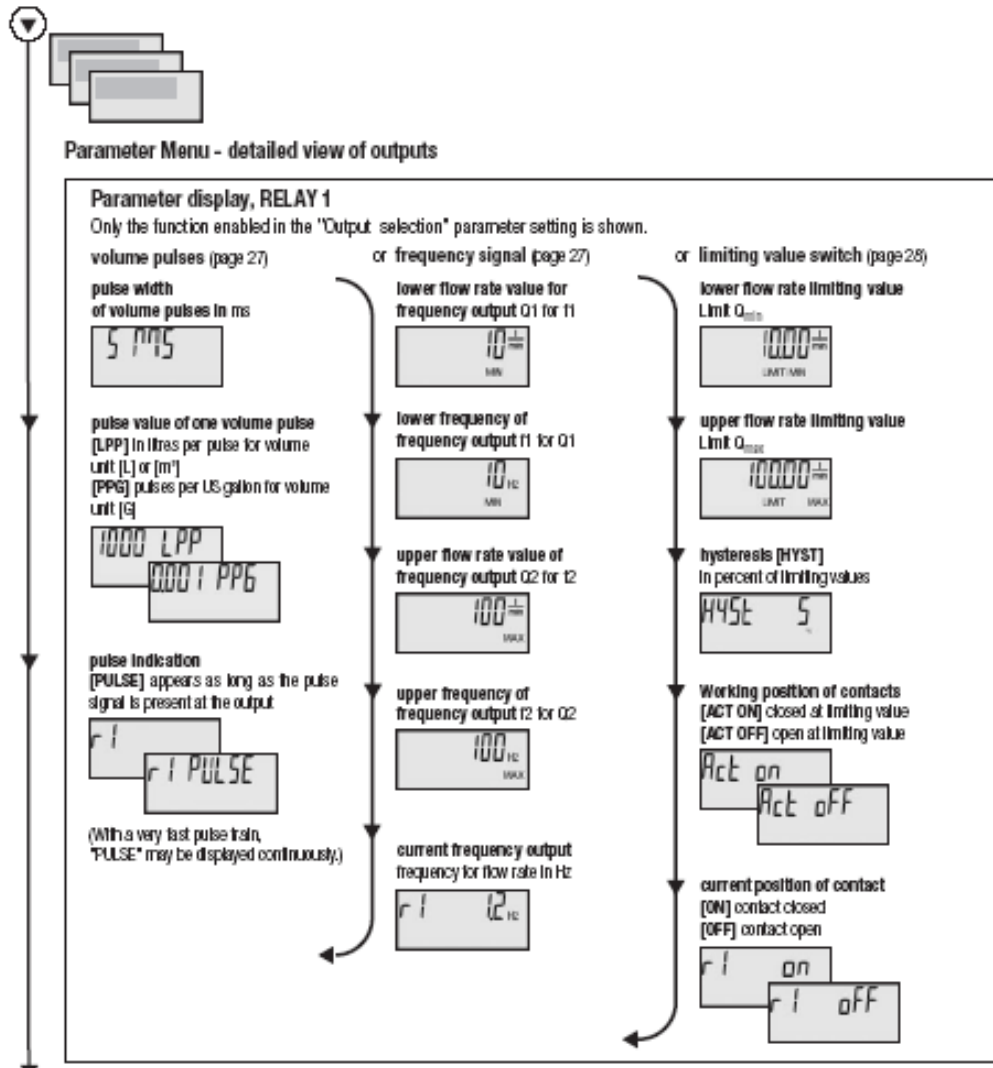

Disable volume subtotal reset [SUBTOT]
[SUB RES] Subtotal can be reset (factory setting)
[SUB.NO.RES] Subtotal cannot be reset

If both keys are pressed at the same time, or if no key is pressed within 15 minutes, the device returns to the standard display.

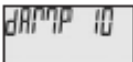
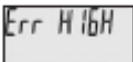

Only the second output enabled in the "Output selection" parameter setting appears (relay 2 or analog)
Parameter display, RELAY 2
 Only the function that is enabled in the parameter setting is shown:
 volume pulses or frequency signal or limiting value switch (for details see relay 1)
 or ANALOG parameter display

	lower flow rate value Q _{min} for 4mA
	upper flow rate value Q _{max} for 20mA
	Attenuation of current output [DAMP] [1] no damping [10] high damping
	Current output in case of an error [ERR...] [HIGH] 21,5mA, [LOW] 3,5mA, [OFF] no output
	current status of current output [ANA] displays the current value of the current output

Main Menu

 If both keys are pressed at the same time, or if no key is pressed within 15 minutes, the device returns to the standard display.

17.2.3.1 Parameter settings

In order to set the parameters, the device must first be unlocked with the Service key. This puts the device into Edit mode.

This is located in the connections compartment and is only accessible after the display module has been opened or unscrewed. The power supply must not be interrupted when this is done.

This unlocking procedure is only possible within the Parameter Menu and is done by pressing the Service key. Once the parameter setting is enabled, symbol  will be shown in addition to all the displays. On exiting the Parameter Menu, the Edit mode is automatically discontinued.

Parameter Menu

Press Service key =

select =

save =

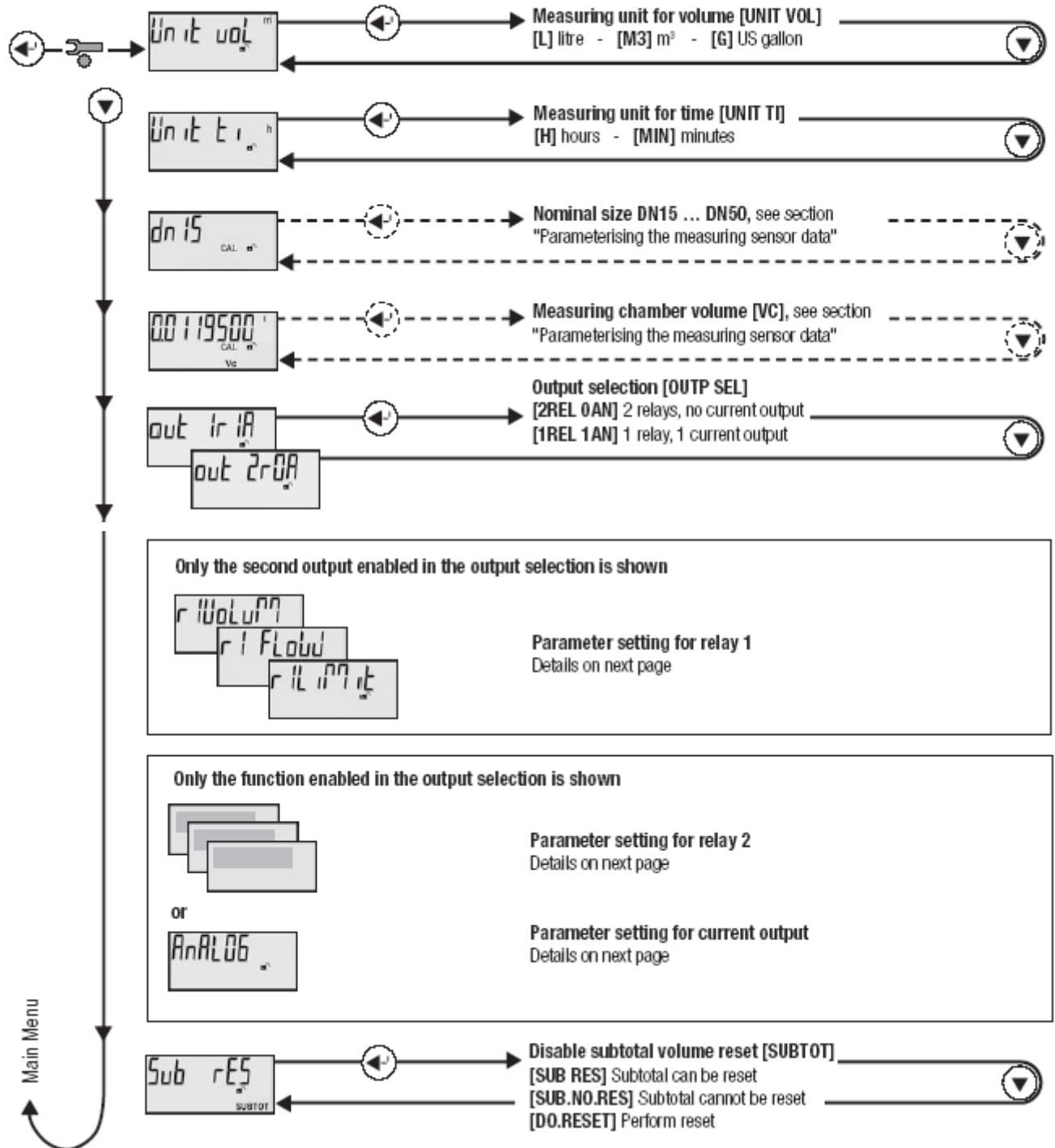

Parameter Menu - set outputs

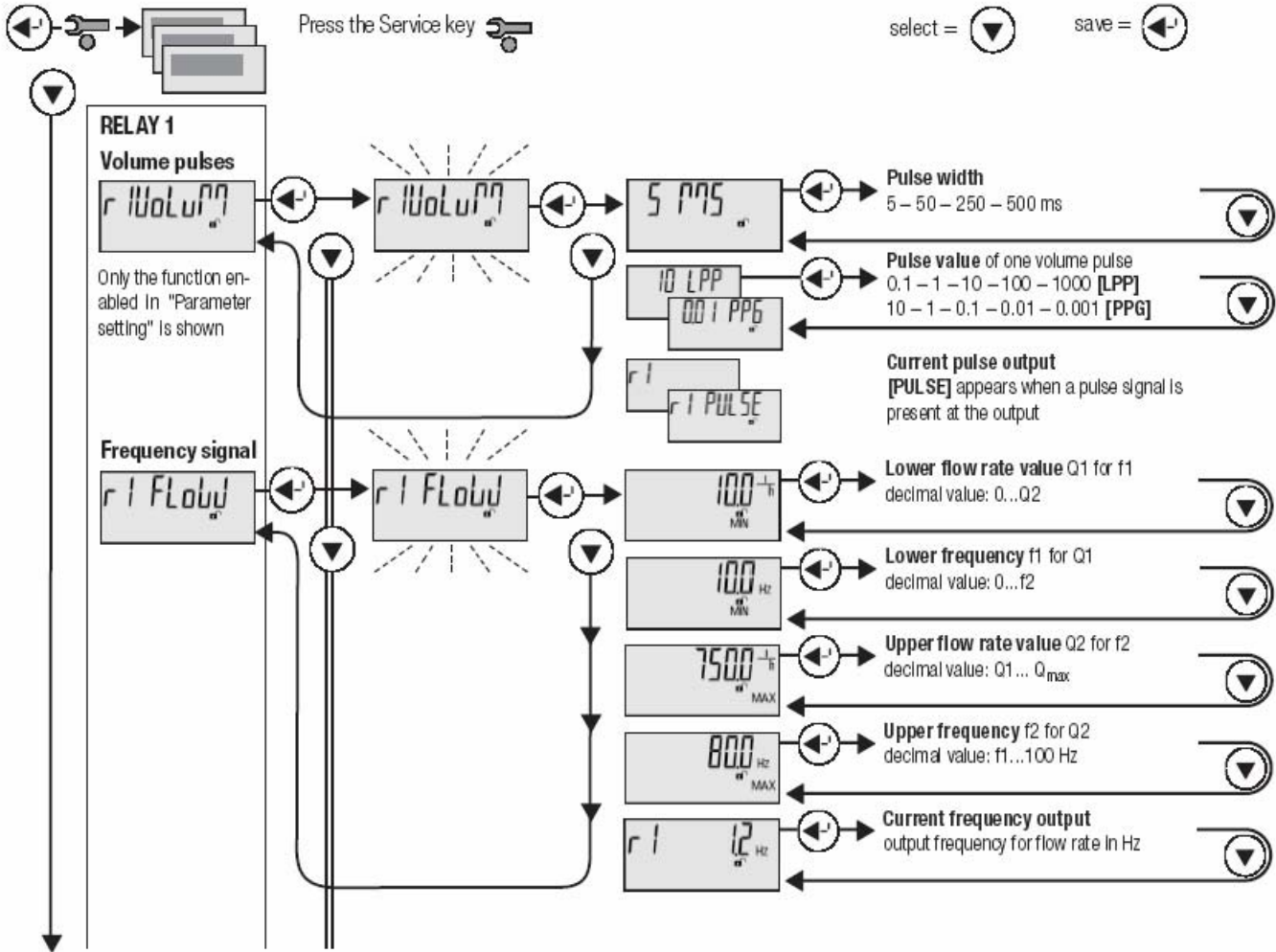

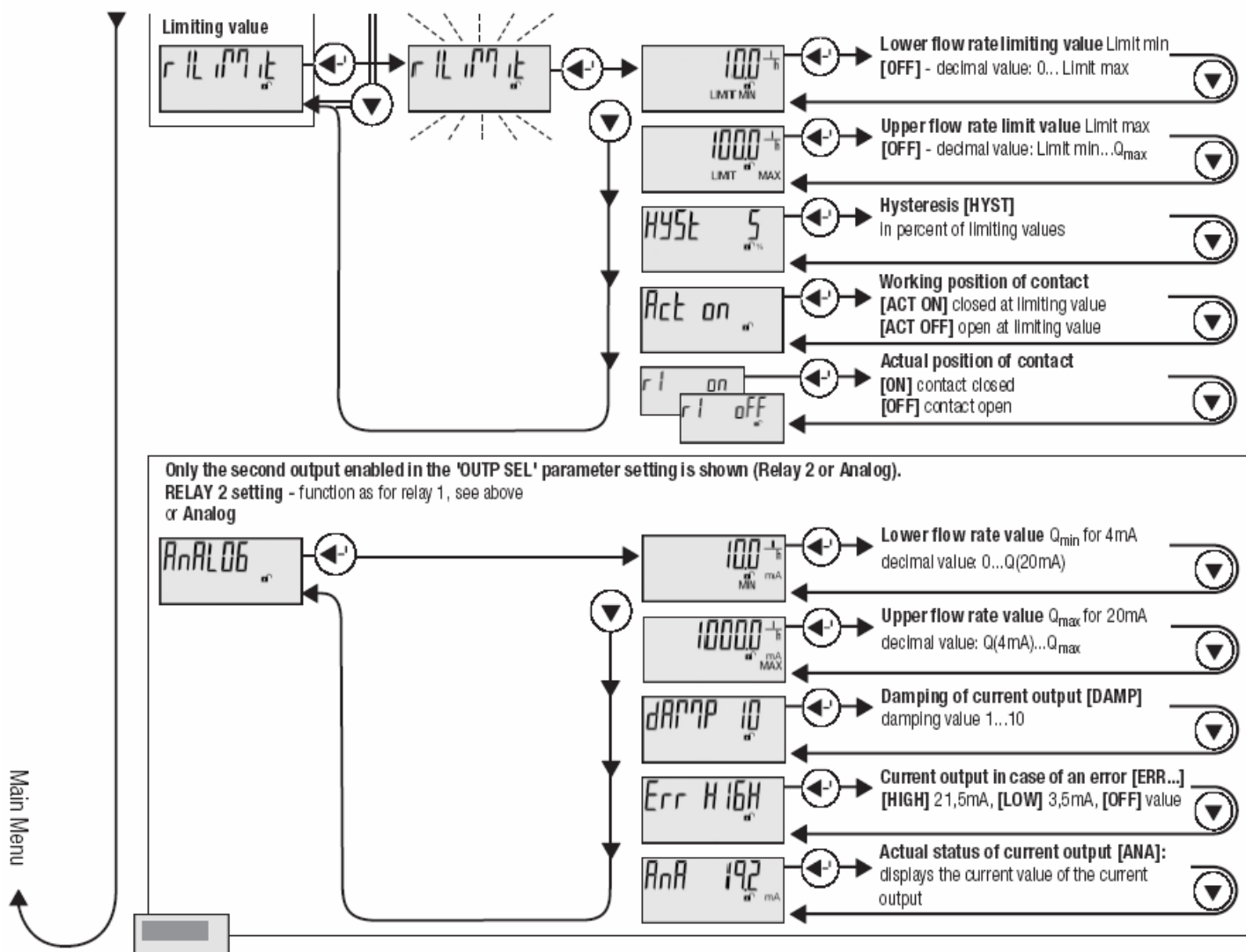

In order to set the individual parameters, the relevant menu item in the Parameter Menu must be found, as above. Press the Enter key to enable editing. The value to be set starts flashing and may be changed.

Selections are available for most of the menu items. Use the Step key to select a desired value and press the Enter key to save it. A saved value no longer flashes.

If discrete numerical values are to be entered as individual digits (e.g. flow rate values), proceed from the smallest decimal place to the largest. The digit to be set will flash. Use the Step key to select the value (0-9) and press the Enter key to accept. Then set the next higher decimal place.

The number of decimal places is fixed. For litres and gallons, one decimal place is specified; four decimal places are specified for m³.

For the limiting value settings, the function of the upper or lower limiting value switch can be disabled if necessary. To do this, an "OFF" selection is also offered when the lowest decimal value for the flow limit is entered.

If no key is pressed within 15 minutes, the device returns to the standard display and the Edit mode is discontinued. Any entries that have not been completed by pressing the Enter key are rejected.

17.2.3.2 Parameterising the display

In order to set the parameters, the device must be unlocked with the Service key. See the section on Parameter setting.

Setting the unit of measurement for volume [UNIT VOL]

Possible settings and subsequent parameters derived from them are as follows:

- litre [UNIT LIT]: pulse value in litres per pulse [LPP], flow in [l/time]
- cubic metres [UNIT M3]: pulse value in litres per pulse [LPP], flow in [m³/time]
- US gallons [UNIT USG]: pulse value in pulses per gallon [PPG], flow in [gal./time]

The set unit of measurement is shown as an index.

Setting the unit of measurement for time [UNIT TI]

Possible settings and subsequent parameters derived from them are as follows:

- hour [UNIT TI h]: flow rate in [Volume/h]
- minute [UNIT TI min]: flow rate in [Volume/min]

The set unit of measurement is shown as an index.

17.2.3.3 Parameterising the flow sensor data

In order to guarantee accurate measurement, the electronics on the flow sensor require adjustment. During calibration in the factory, the data for nominal size and the exact measuring chamber volume are entered for this purpose. These parameters cannot usually be changed again. They are displayed with the index [CAL] to document the calibrated condition of the instrument.

If the measurement transducer has to be replaced, it is possible to enter these two parameters manually in order to "marry" a new measurement transducer with the flow sensor. For spare parts for which the nominal size or measuring chamber volume can be changed, this is shown by the [UNCAL] index.

In order to set the parameters, the device must be unlocked with the Service key..

CAUTION: the settings for the nominal size or the measuring chamber volume can be changed within a maximum time window of 7 days after the first change, and a maximum of 4 changes can be made. After the time window has expired or after the fifth change to these two parameters, NO FURTHER CHANGES ARE POSSIBLE.

17.2.3.4 Parameterising the outputs

In order to set the parameters, the device must be unlocked with the Service key.

The outputs to be used must be enabled in the 'Output selection [OUTP SEL] in the Parameter Menu.

Only enabled outputs can be parameterised. The following alternatives are possible:

- 2 relay outputs (factory setting) or
- 1 relay output and 1 current output

Pulse output for summing the flow volume (totaliser)

Parameter Menu: volume function [R1VOLUM]

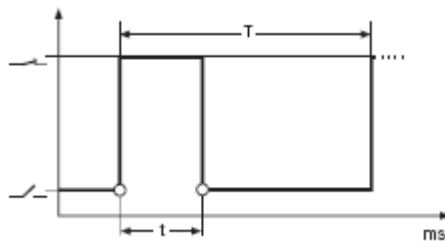

Parameters that can be set:

- Pulse width (t): 5 – 50 – 250 – 500 ms
=> The pulse width determines the smallest possible pulse value.
- Pulse value for litres, m³ [LPP]: 0,1 – 1 – 10 – 100 – 1000 m³ or Ltr/pulse
- Pulse value for US gallons [PPG]: 10 – 1 – 0.1 – 0.01 – 0.001 Pulses/USG
(Factory setting: 250 ms, 1 Ltr/pulse; DN40-50: 10 Ltr/pulse)
=> Based on the pulse width shown above, only those values are offered that can also display the maximum possible flow rate. If a lower pulse value is required other than those, a smaller pulse width must be selected.

Signal behaviour:

When the pulse value is reached, the solid state relay is closed for the duration of the set pulse width.

Frequency output depicting flow rate

Parameter Menu: flow rate function [R1 FLOW]

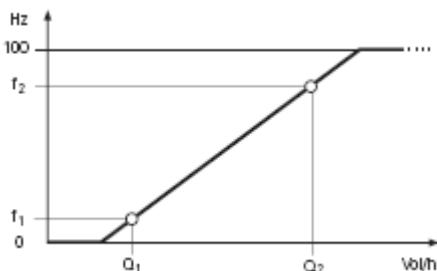

Parameters that can be set:

Frequency range and proportionality of the signal over the desired flow rate measurement range $Q_1 \dots Q_2$

- Lower flow rate [MIN]: $Q_1 \geq 0$ (factory setting: Q_{\min})
- Lower frequency [Hz]: $f_1 \geq 0$ (factory setting: 10 Hz)
- Upper flow rate [MAX]: $Q_2 \leq Q_{\max}$. (factory setting: Q_N)
- Upper frequency [Hz]: $f_2 \leq 100$ Hz (factory setting: 80 Hz)

=> The upper frequency must be larger than the lower frequency.

The upper flow rate value must be larger than the lower flow rate value.

Q_{\min} , Q_N and Q_{\max} are dependent on the nominal size of the meter.

Signal behaviour:

- a) Value falls below the set lower flow rate value Q_1 :
 - proportional decrease to 0 Hz, which is then maintained.
- b) Value exceeds set upper flow rate value Q_2 :
 - proportional increase to 100 Hz, which is then maintained.

No provision is made for error signals.

Switching output to signal a limiting value (Limit)

Parameter Menu: limiting value output [R1LIMIT]

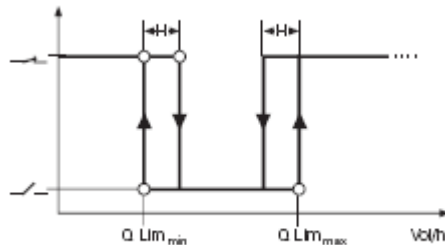

Parameters that can be set:

- Lower flow rate limiting value [LIMIT MIN]:
[OFF] or $Q \text{ Lim}_{\min} \geq 0$
(factory setting: Q_{\min})
 - Upper flow rate limiting value [LIMIT MAX]:
[OFF] or $Q \text{ Lim}_{\max} \leq Q_{\max}$.
(factory setting: Q_N)
- => The upper flow rate limiting value must be larger than the lower flow rate limiting value. Q_{\min} and Q_{\max} are dependent on the nominal size.
- Hysteresis [HYST] (H): 0...10% of Q Lim
(factory setting: 1%)

Working position of the semiconductor switch: active on – active off

Signal behaviour:

- a) For a flow rate lying between the lower and upper flow rate limiting values, the semiconductor switch is open in the "active on" working position. In the "active off" working position, it is closed.
- b) If the upper flow rate limiting value is reached or exceeded, the contact switches to the closed position. It switches back again as soon as the value falls below the upper flow rate limiting value by the hysteresis amount.
- c) If the lower flow rate limiting value is reached or if the value falls below this limit, the contact switches to the closed position. It switches back again as soon as the lower flow rate limiting value is exceeded by the amount of the hysteresis.

Analogue current output (4...20mA) depicting flow rate

Parameter Menu: analogue output [ANALOG]

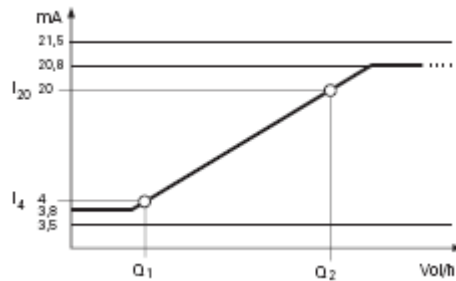

Parameters that can be set:

Proportionality of the signal over a flow rate-range Q_1 to Q_2

- flow rate at 4mA [MIN mA] (I_4): $Q_1 \geq 0$
(factory setting: 0)
- flow rate at 20mA [MAX mA] (I_{20}): $Q_2 \leq Q_{max}$.
(factory setting: Q_N)

=> The upper flow rate value must be larger than the lower flow rate value.

Q_{min} , Q_N and Q_{max} are dependent on the nominal size.

Damping of the signal on rapidly changing measured values

- Damping value [DAMP] 1 (none) ...10 (maximum)

=> The higher the damping, the larger the relative error.

Signal level when a relevant meter error occurs

Error behaviour [ERR ...]: HIGH (21,5mA),LOW (3,5mA), OFF

Signal behaviour:

- a) Value falls below the set lower flow rate value Q_1 :
 - proportional decrease to 3.8mA which is then maintained.
- b) Value exceeds set upper flow rate value Q_2 :
 - proportional increase to 20.8mA which is then maintained.
- c) Error signal for measurement-relevant meter error (sensor, ROM, supply voltage, etc.):
 - For HIGH error behaviour: output 21.5mA
 - For LOW error behaviour: output 3.5mA
 - For OFF error behaviour: no error signal, continued output of computed value.

17.3 Error messages

The electronics perform a self-test about every 5 minutes. If an error is detected which impairs the reliability or accuracy of the measurement, the [ERROR] warning will appear every 2 seconds on the display.

The error is shown in detail in the Information Menu:

- [E-FLOW] maximum permitted flow rate (Qmax) exceeded
The meter is mechanically overloaded and is no longer measuring accurately.
Action: reduce the flow rate or use the next higher nominal size.
- [E-POWER] supply voltage is too low
Faulty data processing, meter supplies incorrect measured values.
Action: check the voltage supply and eliminate the cause of the error (if applicable).
- [E-EEP] error when reading or saving data to EEPROM, faulty data backup.
Totaliser value may be incorrect.
Action: measurement transducer must be replaced. Please contact the supplier.
- [E-ROM] error when reading data from the ROM
Faulty data processing, meter supplies incorrect measured values.
Action: measurement transducer must be replaced. Please contact the supplier.
- [E-SENSOR] signal error from flow sensor to measurement transducer
Meter supplies incorrect measured values.
Action: measurement transducer must be replaced. Please contact the supplier.

17.4 Maintenance

Check connections periodically for tightness and if necessary tighten again.

For control and cleaning, the measuring chamber and the ring piston of the meters DN15 - 50 can be removed without dismantling the meter from the pipe.

The cleaning and revision cycle depends largely on the conditions of operation. Under favourable conditions 5 - 10 years suffice.

Check the units for corrosion. When ancillary equipment is used, observe their mounting and operation instructions.

Please, contact Auramarine Ltd for spare parts.

18 HEAT EXCHANGER TYPE MX

18.1 General Description

Vesta MX heat exchangers are of the shell and tube type with u-bend tubes. All heaters have been hydrostatic pressure tested before delivery. Vesta MX heat exchangers have been type approved by all major classification societies.

18.2 Operation

18.2.1 Commissioning

Before start-up it is important to make sure that all connections are securely tightened. Before start-up it is equally important that the heater is filled 100% with liquid and that all connecting pipes are thoroughly air-vented.

NOTE: Remember to retighten the air ventilation plug.

18.2.2 Initial start-up



Fluid flow through the heat exchanger must be established before the heating medium is applied.

Operate the heater for one hour, stop, and retighten all screws.

18.2.3 Output

The output of the heater is subject to the supply of heating media at the inlet steam valve. The steam pressure/heating media temperature applied is to be according to heater size calculation. The output is furthermore subject to correct type of steam trap being used. Correct layout of the condensate system avoids negative effect of counter pressure.

18.2.4 Conservation during shut down periods

Corrosion occurrences in shut down periods are mainly caused by oxygen. The corrosion occurs if non-distilled or alkaline water remains in the heat exchanger. However, even when fully emptied, heaters are exposed to corrosion caused by water residues or condensation. Hence, heaters out of service should be protected against corrosion.

If the heater is out of service for an extended period of time – in particular during winter seasons with frost – it must be carefully emptied. Open the air escape valve and check for clogging.

18.3 Maintenance and cleaning



During disassembly, inspection, reassembly and testing it is important that all safety measures are observed.

The fluids in the systems can be both hot and flammable. Therefore it is important during disassembly and cleaning that proper depressurising, isolation and draining is performed, as well as spillage control. The mandatory pressure test is to be carried out with great care.

Insulation and splash guards must be fitted during recommissioning.

18.3.1 Regular cleaning periods

The heater should be cleaned regularly every six months by removing the tube insert, or at any time there is a decrease in output not related to other causes.

NOTE: The heat exchanger must be emptied before removing the tube section.

Check if any deposits have collected on the tubes.

18.3.2 Cleaning of tubes

Cleaning of the tube system from the outside is carried out after removing the tube insert using a sharp liquid jet (citric acid or water).

Cleaning of the tube system from the inside is carried out after removing the cover by flushing the tubes with e.g. citric acid.

18.3.3 Heavy contamination

If the heater is heavily contaminated with carbon deposits, the manufacturer recommends the heater chemically cleaned with a carbon remover.

After the cleaning has been completed, the heater must be flushed carefully with fresh water and allowed to dry afterwards.

18.3.4 Checking the safety valves

Once every year the safety valve must be checked for correct setpoint.

18.3.5 Dismantling and reassembling of the tube section

The tube section is inserted into the heater and fastened tightly between the shell flange and the end flange. The back end of the tube section is not fixed.

The primary connection for heating media must be dismantled before dismantling the tube section for inspection, cleaning, etc. The tube flange has threaded holes for dismantling screws and for mounting eyebolts for lifting devices.

Gasket surfaces are to be cleaned and protected against damage. New gaskets are to be fitted every time the flange connection has been dismantled.

NOTE: Fluid flow through the heat exchanger must be established before the heating medium is applied.

Tighten all main flange bolts according to below schedule. Operate the heater for one hour, stop, and retighten all bolts according to the table below.

NOTE: A pressure test should be carried out to prove tight joints.

Heater	No bolts	Size	Torque (Nm)	Tightening schedule
MX10	8	M16	50	1 4 7 2 5 8 3 6
MX15	8	M20	83	1 4 7 2 5 8 3 6
MX20	12	M20	79	1 7 11 4 9 2 6 12 5 10 3 8
MX25	12	M24	137	1 7 11 4 9 2 6 12 5 10 3 8
MX30	12	M24	186	1 7 11 4 9 2 6 12 5 10 3 8
MX40	16	M27	245	1 9 5 13 8 16 12 4 15 7 3 11 6 14 10 2

Heater main flange bolts tightening schedule (dry values) – T16 types

18.4 Spare parts

When ordering spare parts, please state the serial number of the heat exchanger (located on the nameplate). For spare parts and further information, please contact Auramarine Ltd.

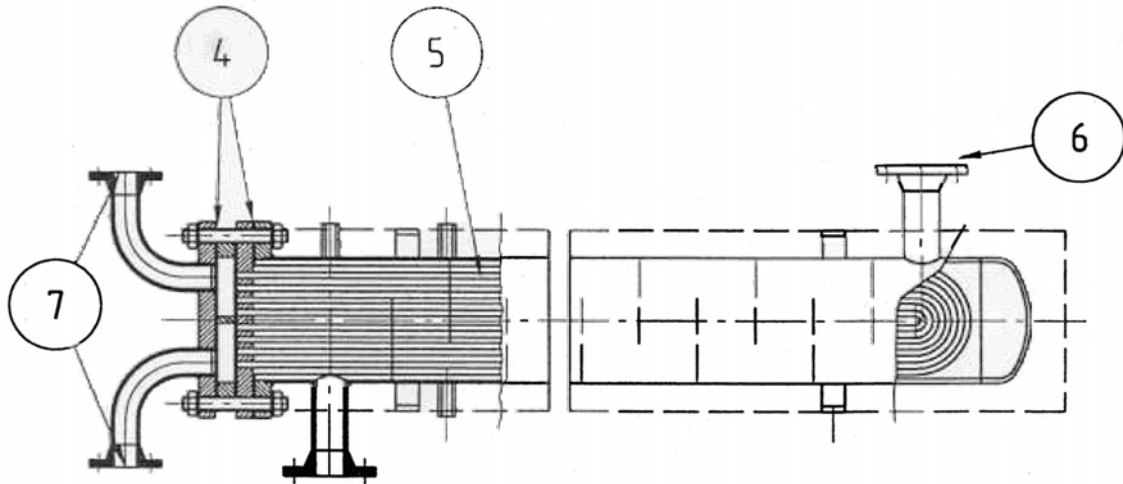

- 4 Flange gaskets
- 5 Tube insert
- 6 In and outlet flange gaskets
- 7 Steam and condens flange gaskets

19 ELECTRIC MOTOR, TYPES 7A*, 7B*, 14BG*



Electric motors have dangerous voltage carrying and rotating components.

The surfaces of the motor become hot.

All work involved in the transport, connection, commissioning and regular maintenance must be carried out by qualified, responsible specialists (note VDE 0105; IEC 364).

Improper behaviour may result in serious injury and damage to property.

The applicable national, local and works regulations and requirements must be complied with.

Utilization in areas subject to explosion hazard is not permitted, unless expressly intended for this purpose.

19.1 General information

The motors are rated for ambient temperatures of -20° C to +40° C and site altitudes <1000m above sea level. Any contradictory information on the rating plate must be observed. The conditions on site must correspond to all rating plate specifications.

When motors with roller bearings for increased cantilever force are operated the value of cantilever force must be minimal 30% of permissible cantilever force. Operating with smaller cent lever force is the cause of bearing faults.

A canopy is recommended for designs with the shaft end pointing downwards, and with the shaft end pointing upwards a cover must be provided by the customer to prevent foreign bodies from falling into the fan.

Do not obstruct ventilation! Discharged air, also from neighbouring equipment, must not be sucked in again immediately.

Checking of bearing grease must be carried out when motors are stored longer than 12 months. When storage conditions are the cause of grease depreciation (presence of condensate, consistency change) the grease must be exchanged. Grease exchange must be carried out no later than in three year interval.

19.2 Operation and maintenance

Vibration levels of $V_{rms} < 3,5 \text{ mm/s}$ ($P_N \leq 15 \text{ kW}$) or $V_{rms} \leq 4,5 \text{ mm/s}$ ($P_N > 15 \text{ kW}$) are quite acceptable in the coupled state.

If deviations from normal operation occur - e.g. increased temperatures, noises, vibration - the motor should be switched off in the event of doubt. Determine the causes and contact Auramarine Ltd if necessary. Do not disconnect protective equipment, even under test operation.

Under dirty operating conditions, clean the air channels regularly. Open any closed condensate water holes from time to time!

For motors without regreasing facilities, bearing or grease replacement must be carried out according to the table below or after 3 years, whichever is sooner.

Bearings with regreasing facilities must be regreased when the motor is running. Please note the greasing plate!

Some of the motors have a separate nameplate with information about the bearings and the lubrication intervals.

If the motors have separate ventilation, the separately-driven fan must be switched on throughout motor operation.

19.2.1 Lubrication

In the case of motors operating under special conditions, such as vertical motor position, frequent operation at maximum speed n_{max} , heavy vibration, sudden load changes and frequent reversing operation, the bearing should be changed at considerably more frequent intervals than at the operating hour stated above.

Motor size	Poles	Bearing Drive end	Bearings Non drive end				
4AP 56 7AA 56	2 to 8	6200-ZZ C3 6201-ZZ C3	6200-ZZ C3 6201-ZZ C3	The motors are permanently lubricated; the grease lifetime is for CT 25°C			
4AP 63 7AA 63		6201-ZZ C3 6201-ZZ C3	6201-ZZ C3 6201-ZZ C3	* 2-pole motors 20 000 h * 4-pole motors and higher 40 000 h			
7AA 71 7AA80 7AA90 7BA/7AA100		6202-ZZ C3 6204-ZZ C3 6205-ZZ C3 6206-ZZ C3	6202-ZZ C3 6204-ZZ C3 6205-ZZ C3 6206-ZZ C3	The bearing lifetime is the grease lifetime for enclosed bearings (ZZ). The nominal bearing lifetime is > 100 000 h for a coupling drive.			
7AA112 7BA112 7AA132 7BA132 7AA160		6306-ZZ C3 6306-ZZ C3 6208-ZZ C3 6308-ZZ C3 6209-ZZ C3	6306-ZZ C3 6306-ZZ C3 6208-ZZ C3 6308-ZZ C3 6209-ZZ C3	At speeds up to 1800 rpm: 15000 hours At speeds above to 1800 rpm: 7500 hours.			
7BA160 14BG size 180 14BG size 200 14BG size 225 14BG size 250			6309 C3 6310-C3 6312 C3 6313 C3 6315 C3	6309 C3 6310-C3 6312 C3 6313 C3 6315 C3	Lubrication 160-180 160-180 200-225 200-225 250 250	Poler 2 4,6,8 2 4,6,8 2 4,6,8	Interval 40°C 4000h/20g 8000h/20g 4000h/20g 8000h/20g 4000h/25g 8000h/25g
14BG size 280		2	6217 C3	6217 C3	280	2	4000h/25g
14BG size 280		4 to 8	6317 C3	6317 C3	280	4,6,8	8000h/30g
14BG size 315		2	6316 C3	6316 C3	315	2	3000h/30g
14BG size 315		4 to 8	6319 C3	6319 C3	315	4,6,8	6000h/40g

Type of grease for standard machines: (Fa. ESSO / UNIREX N 3).
Compensatory greases must conform to DIN 51825 - KL3N at least. In this case the lubrication intervals at $T > 25^{\circ}\text{C}$ are to be reduced.

Special grease are introduced on the lubricating data plate.

19.3 Electrical connection

Work is only permitted to be carried out by qualified specialists on the stationary motor, while disconnected and prevented from being switched on again. This also applies for the auxiliary power circuits (e.g. Anti-condensation heaters).



Check that the equipment is potential-free!

If the tolerance limits are exceeded that are specified in EN 60034, part 1 / IEC 34-1 (voltage $\pm 5\%$, frequency $\pm 2\%$, shape of curve, symmetry) the heating effect is increased and the electromagnetic compatibility is affected. Please note the specifications on the rating plate and the connection diagram in the terminal box.

Connections must be made in such a way as to ensure that a permanently safe electrical connection is maintained (no protruding wire ends) use the corresponding cable end pieces. Create a safe earth continuity connection.

Clearances in air between bare live parts themselves and between bare live parts and earth must be $\geq 5,5 \text{ mm}$ ($U_{\text{rated}} \leq 690 \text{ V}$).

It must be ensured that the terminal box does not contain foreign bodies, dirt or humidity. Seal any unused cable entry openings against dust and water.

Secure the featherkey on test operation without drive components. For motors with brakes, check that the brakes are operating perfectly before commissioning.

Tightening torques for terminal board connections

	M4	M5	M6	M8	M10	M12	M16
Tightening torque (Nm)	0,8...1,2	1,8...2,5	2,7...4	5,5...8	9...13	16...20	36...40

19.4 Spare parts

Frame sizes 63-160

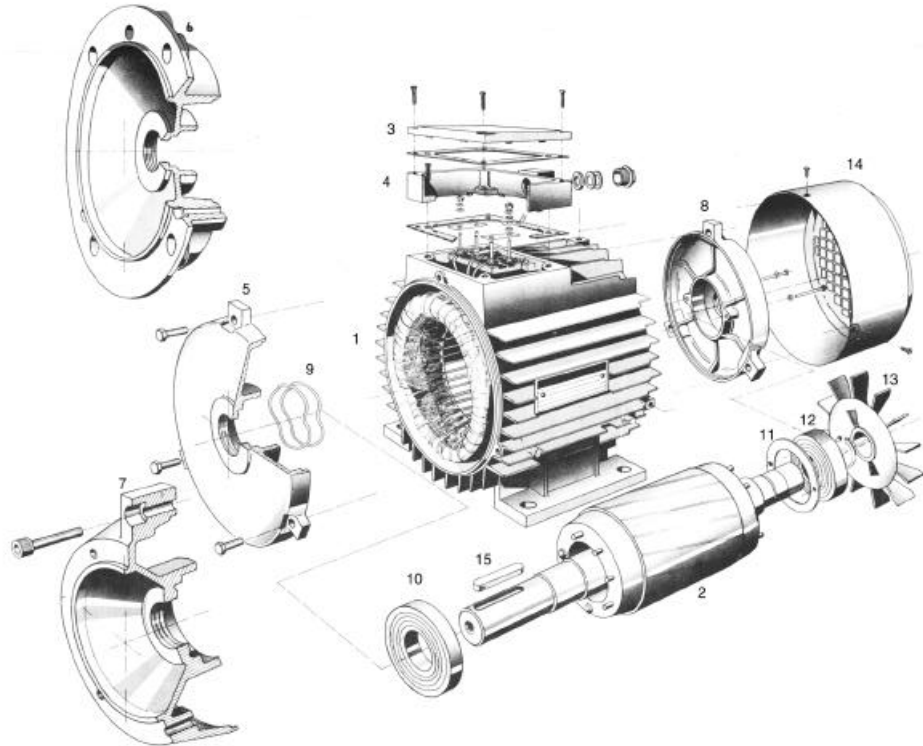

1. Stator - complete with winding
2. Rotor
3. Terminal box cover
4. Terminal box
5. Endshield B3, drive end
6. Endshield B5, drive end
7. Endshield B14A, drive end
8. Endshield, non-drive end
9. Anti-bump washer
10. Bearing, drive end
11. Bearing, cover
12. Bearing, non-drive end
13. Fan
14. Fan cover
15. Key

Frame sizes 180-315

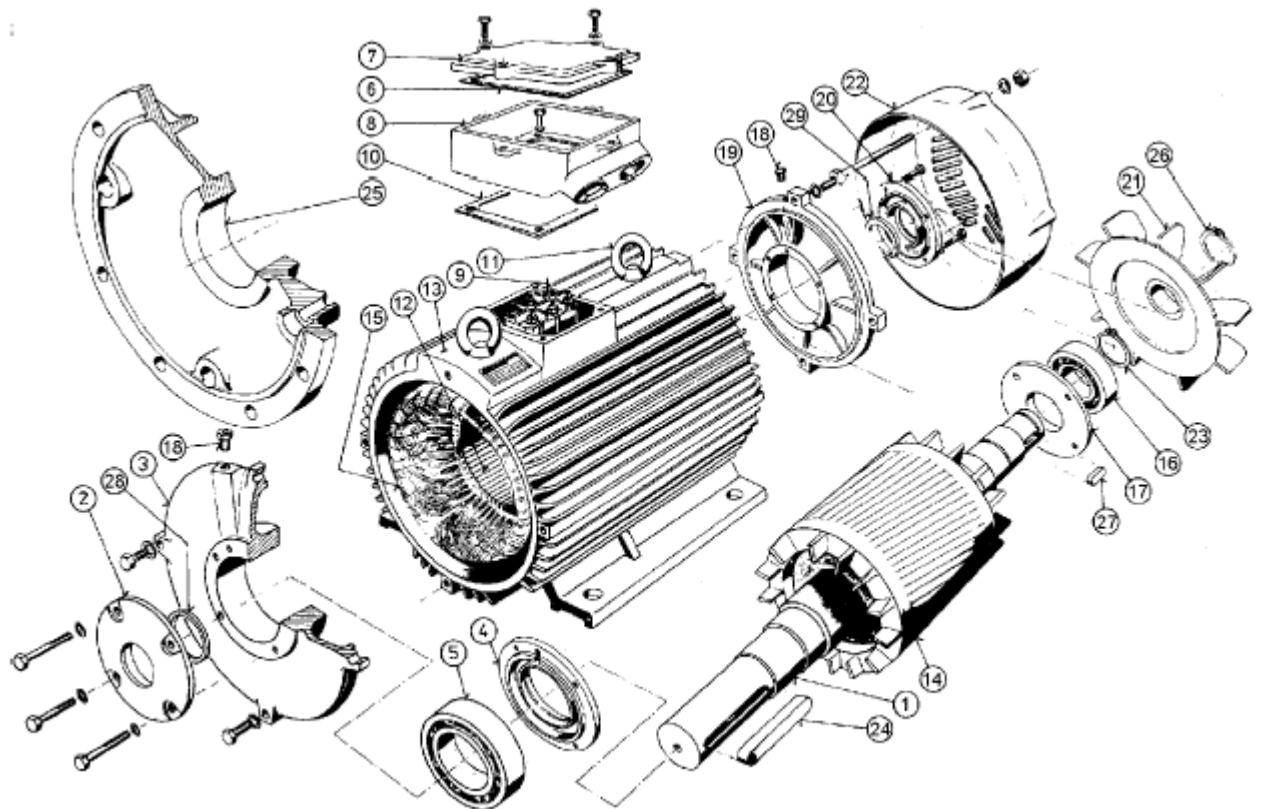

1. Shaft
2. Bearing cap, drive end
3. Rear endshield
4. Bearing cap, drive end internal
5. Bearing, drive end
6. Sealing of the terminal board cover
7. Terminal board cover
8. Terminal box
9. Terminal board
10. Sealing of the terminal box
11. Eye bolt
12. Stator core
13. Frame
14. Rotor core with the cage
15. Stator winding
16. Bearing, non-drive end
17. Bearing cap, non-drive end internal
18. Lubricating nipple
19. Front endshield
20. Bearing cap, non-drive end
21. Fan
22. Fan cover
23. Retaining ring (of the bearing on the shaft)
24. Key
25. Flange shield
26. Retaining ring (of the fan)
27. Key of the fan
28. Shaft sealing ring, drive end
29. Shaft sealing ring, non-drive end

20 ACG SCREW PUMP



Before any maintenance work, ensure that the driver is deenergized and the pump hydraulically isolated.

All work carried out on the pump has to be performed in such a manner that risks for personal injury are observed!

When handling liquids, which may involve fire hazards, appropriate precautions to avoid danger are to be taken.

In case of failure for a system with elevated pressure, fluid jets may cause injury and/or damage.

Connecting and disconnecting of electric cables must be done only by personnel authorised to do such work.

If the pumps operating temperature exceeds 60°C, let the pump cool off before any service, maintenance or dismantling work is commenced to avoid burn injury.

Starting a dry pump is likely to cause damage, especially to the shaft seal.

When handling liquids that may harm skin, use gloves and/or protective clothing.

Oil leakage may make the floor slippery and cause personal injury.

Sectional view of ACG screw pump

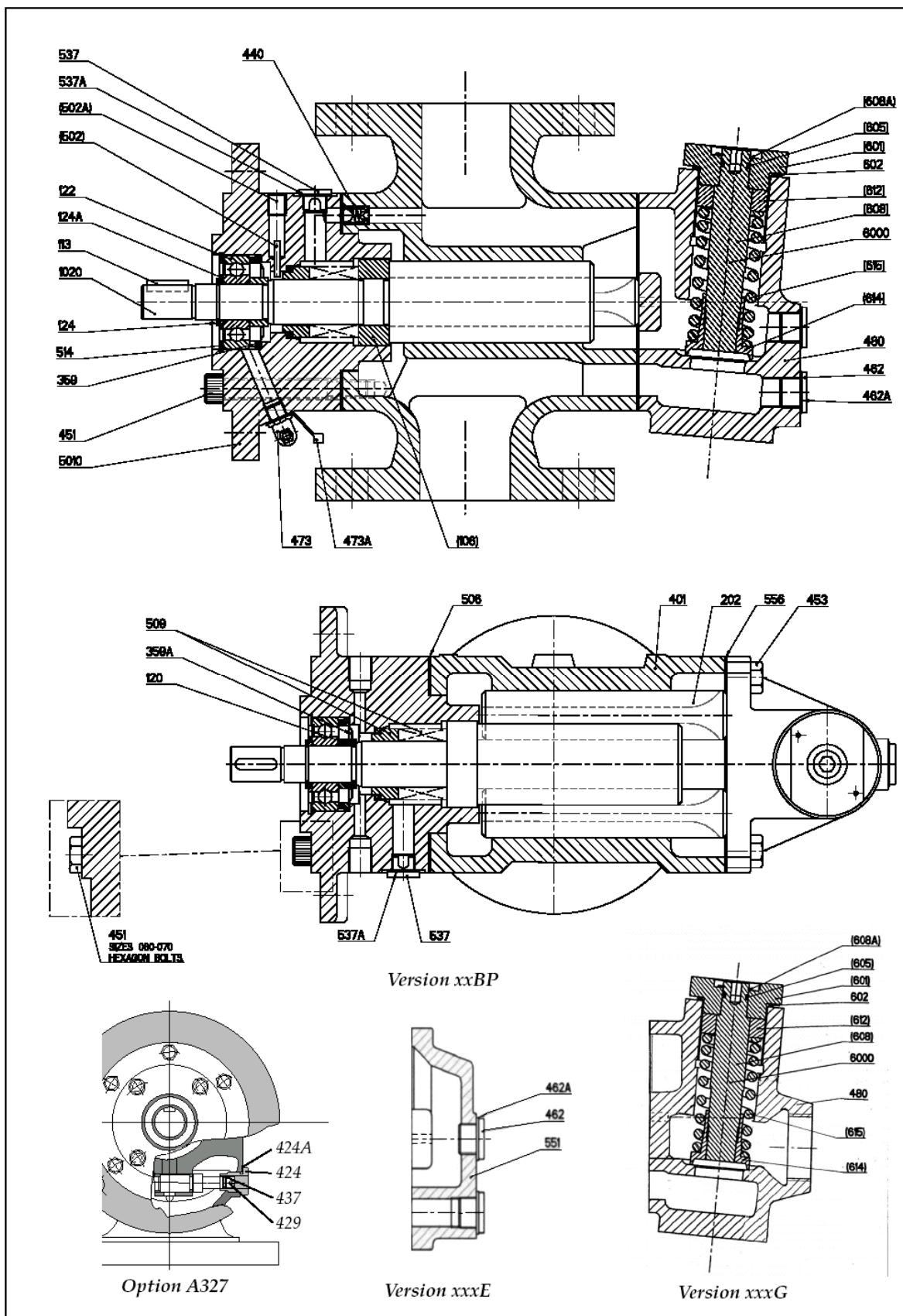

Fig. 5

20.1 Start-up of ACE and ACG pumps

20.1.1 Before starting

After installation and whenever it can be assumed that the pump has been emptied, the pump must be thoroughly filled with liquid. See figure below.

For ACE Generation 3, ACG Generation 6 and ACF Generation 4 delivered after 1997, the pumps has been fitted with deaeration plugs making venting of the shaft seal compartment easy before start-up. In installations with positive suction pressure: After opening the inlet and outlet valves, simply open the deaeration plug a few turns until oil sips out. Tighten the plug.

In installation with negative suction pressure: After opening the inlet and outlet valves, remove the deaeration plug and fill the shaft seal compartment with oil. Fit and tighten the plug. See fig. 16. Note! Not applicable on LPQ/ABQ.

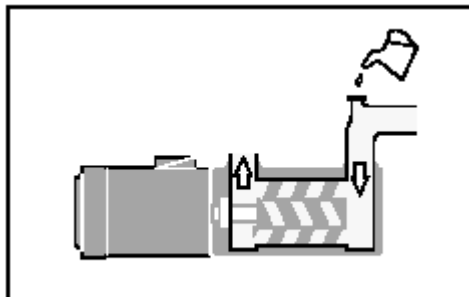

Fig. 15 Filling the pump

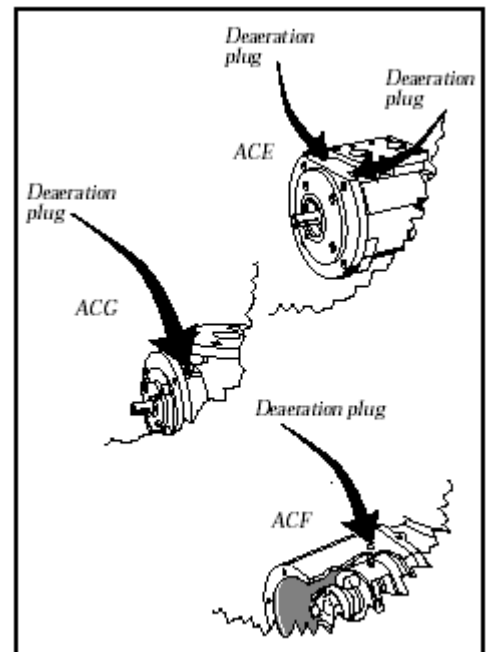

Fig. 16 Deaeration plugs



Make sure the prime mover is locked out and cannot be started accidentally.

Rotate the shaft by hand while filling the pump to ensure that the rotor bores and the shaft seal cavity is filled. On the smaller pumps (LPD, ACD, ACE, ACG/UCG), this is done by rotating the electric fan motor after removing the fan cover.



Do not forget to fit the motor fan cover again before making start of motor possible.

Starting a dry pump is likely to cause damage, especially to the shaft seal.

20.1.1.1 Direction of rotation

When the pump is ready to be started, switch the motor briefly on and off and check that the drive motor rotates in the correct direction as indicated by the rotation arrow.

The arrow is placed on different spots depending on the pump series.



Do not mix up with arrow for inlet and outlet!

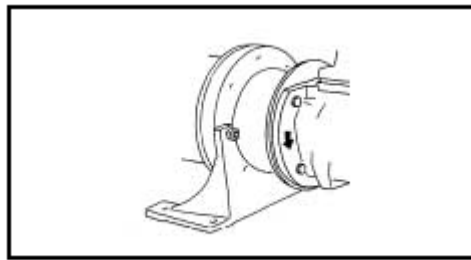

Fig. 17 Direction of rotation

20.1.2 Starting ACE and ACG pumps

Check that all valves necessary for the operation are fully opened in both discharge and suction lines. The first time, the pump should be started with the adjusting spindle of the pressure relief valve tightened to half of the available turns (the valve setting is increased when the spindle is turned clockwise). By monitoring the pressure gauge it can be determined when the suction line is primed and the pump begins to work. Should the pump not operate normally soon after start, stop the pump within half a minute. Start again after about 3-5 minutes (the shaft seal must have time to cool off) and run for half a minute. This procedure may need to be repeated a couple of times if the suction line is extremely long. Should the pump still not work, it must be assumed there is a problem in the system that needs to be remedied. Check the suction line calculation on page 5 and/or see "Trouble shooting", which is explained later.



Pumps with external ball bearing including grease nipple, must be regreased after one hour of running, while the pump is operating.

20.1.2.1 Setting the pressure relief valve

The setting of the opening pressure is made as follows: Tighten the valve spindle by rotating clockwise to the maximum extent. The system pressure is regulated by throttling to required value. The pressure relief valve is eased until the pressure is just beginning to decrease by turning the spindle CCW. The valve is now preset for desired opening pressure. Open the throttling valve entirely.

NOTE: The set screw on LPD is hidden behind a plate.

20.1.2.2 Adjusting the tuning

The tuning adjustment, which is a standard feature on ACF/UCF and LPQ (option on ACG/UCG and ABQ) pumps, is a device for minimizing the effects of dissolved and free air in lube oil systems. The tuning principle is described in the Product Description. The tuning should be adjusted while the pump is working under normal operating conditions. This is done by turning the tuning spindle with an Allen key (size 8 mm for ACG/UCG, 12 mm for ACF/UCF and LPQ) to a position where the noise level comes to a minimum.

Setting of tuning of the ACG/UCG and ACF/UFC:

1. Before starting the setting, check that the setting screw (8 mm: ACG/UCG, 12 mm: ACF/UCF, socket head cap screw on the discharge side) are closed.

Turn the screw CCW until the noise level becomes the lowest (if turned too much the noise will increase again)

Once set, the tuning needs no further adjustment, providing the operating conditions stay the same.

NOTE: It is not possible to accidentally turn the tuning spindle too far.



If operating temperature exceeds 60°C (149°F), appropriate measures to avoid skin contact shall be provided.

Use hearing protections whenever high noise can be expected from pump, motor and/or environment.

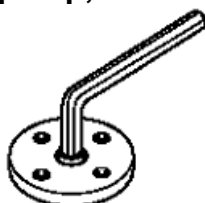

Fig 18: Adjusting the tuning

20.2 Maintenance



All work carried out on the pump has to be performed in such a manner that risks for personal injury are observed!

The intervals for inspection and replacement of wear parts vary greatly with the properties of the pumped liquid, and can only be determined by experience. All internal parts of the ACG- pump are lubricated by the pumped liquid. Pumping liquid, which contains abrasive materials or liquid that is corrosive, will significantly reduce service life and call for shorter service intervals. Wear in the pump may be indicated by:

- Vibration
- Noise
- Loss of capacity
- Reduction in flow/pressure
- Leakage

In installations, where unplanned shutdowns must be avoided, it is advisable to have a complete pump available for replacement, should any malfunction occur. Furthermore, planned inspection and overhaul at regular intervals, not exceeding three years, is recommended.

It is recommended always to have the spares included in minor spare part kit available.

For maintenance the following spare part sets are recommended:

Set	To be used
G057	Joint kit
For dismantling of the pump	

Set	To be used
G053	Minor kit
For service	

Set	To be used
G054	Major kit
For repair after damage or greater wear	

Ordering example: For IMO-pump ACG 04N7 NVBP, serial number 456789 Shaft seal pos G050 p/n 190335 Ball-bearing pos 122 p/n 068578

20.2.1 Inspection of shaft seal

As the seal faces of a mechanical shaft seal are lubricated by the fluid, a certain leakage will always be present. Ten drops per hour can be considered as acceptable.

An external visual inspection of the pump is advisable at least every two days to assure that the shaft seal is not leaking too much.

Excessively leaking shaft seals should be changed without delay, as the leakage normally will grow worse and cause additional damage.

Follow the instructions in the “Dismantling/Re-assembly” session.

When working with a shaft seal, cleanliness is of utmost importance. Avoid touching the seal faces. If necessary, the seal faces should be cleaned immediately prior to assembly, using a dust-free cloth and clean solvent.

Never use grease on the seal faces.



Connecting and disconnecting of electric cables must be done only by personnel authorised to do such work.

If the pumps operating temperature exceeds 60°C, let the pump cool off before any service, maintenance or dismantling work is commenced to avoid burn injury.

20.2.2 Shaft seal - assembly drawing

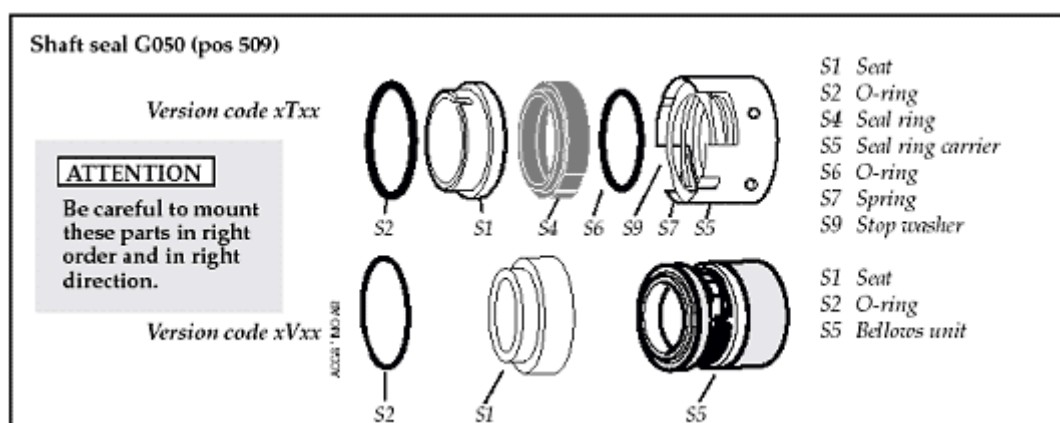

20.2.3 Service for ball bearing

The ACG- pump is fitted with an external grease lubricated ball bearing.

When delivered from Auramarine LTD, the ball bearings in pump version xRxx and xVxx are filled with grease of type B. For version xTxx, type C is used. Whenever the ball bearing is removed, it is recommended to exchange it for new one.

Fit the new ball bearing properly greased and re-grease it after one hour of running, while the pump is operating.

Use an appropriate type of grease, as per table and a grease gun suitable for grease nipple (pos. 473) according to DIN 71 412 (ISO 6392).

On vertical mounted units the greasing intervals are reduced to half.

Installed in dusty or dirty premises or in a corrosive environment it should be lubricated at more frequent intervals.

If using others than these recommended greases, check if it is possible to mix them with each other, otherwise clean before using new grease.

Useful tools

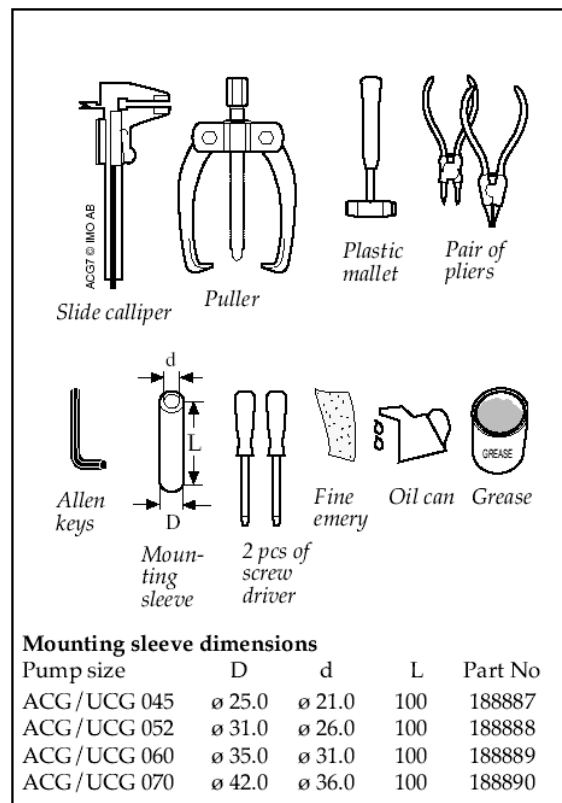

Fig. 4

20.2.4 Lubricating intervals in working hours

Temp max °C	Grease type	Pump sizes 045 and 052						Pump sizes 060 and 070					
		Speed r/min						Speed r/min					
		3500	2900	1750	1450	1150	950	3500	2900	1750	1450	1150	950
70	A	8500	10000	10000	10000	10000	10000	7500	8500	10000	10000	10000	10000
90	A	3350	3950	5350	5950	6350	7500	2950	3350	4750	5150	5950	6750
110	B	2650	3150	4250	4700	5000	5950	2350	2650	3750	4100	4700	5350
130	B	1050	1250	1650	1850	2000	2350	900	1050	1500	1600	1850	2100
155	C	650	750	1050	1150	1250	1500	600	650	950	1000	1150	1300

*) at rotation speed > 3 500 r/min special instructions are given by Auramarine LTD. Recommended greases (the availability of the greases can differ locally):

Type A: BP Energrease LS 3, Esso Beacon 2, Mobilgrease HP 222, Shell Alvania G3, Texaco Multifak EP2, SKF LGMT2, Q8 REMBRANDT EP2, CASTROL APS2, ELF ROLEXA 3, TOTAL MULTIS TIR EP3, FINA MARSON L3.

Type B: BP Energrease LC2, CHEVRON SRI GREASE 2, Esso Unirex N3, Mobilith SHC220, SHELL RETINAX LX, SHELL Albida LX, VAL-PLEX EP GREASE, Texaco Hytex EP2, SKF LGHQ 3, QS RUBENS, CASTROL LMX, INDUSTRIAL GREASE HEAVY, TOTAL MULTIS THT2, FINA PLUTON L2.

Type C: Mobilith SHC 460

Pump size	045	052	060	070
Grease amount (g)	4	6	7	9



When handling liquids that may harm skin, use gloves and/or protective clothing.

Oil leakage may make the floor slippery and cause personal injury.

20.2.5 Inspection of rotors

If an indication of a worn pump is noticed (see service intervals above), a brief inspection of the idler rotors is recommended.

A quick inspection of the idler rotors can be made simply by removing the rear cover or valve cover. Note that the driver must be de-energised and the pump hydraulically isolated before the rear cover is removed.

Provisions to handle the fluid are to be made. If a more thorough investigation is needed, proceed as under "Dismantling".

Internal clearances in the pump, which are vital for its proper function, may have been affected by wear. Acceptable wear can be determined only by experience of the actual application. As a rule of thumb, the following max. clearance values may apply:

- Between rotor and bores or bushings: 0.2 mm
- Between rotor flanks: 0.4 mm

For light duties (low-pressure, medium viscosity) even bigger clearances may be acceptable, but for low viscosity/high -pressure duties, the limit will be lower. Also check if there are major scratches on these parts.

20.2.6 Dismantling

A.

- Turn the electricity OFF
- Close the valves
- Remove the pump from the system.

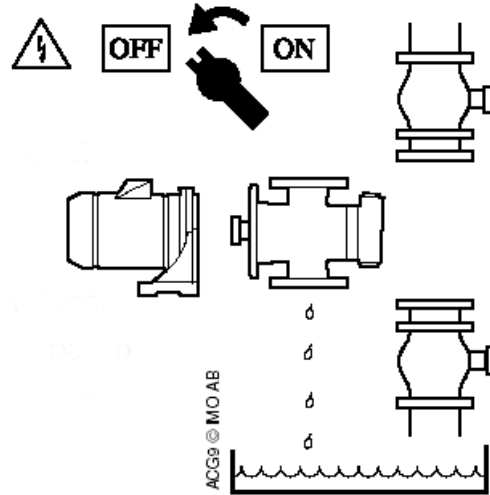

NOTE

Use appropriate vessels to collect oil spillage when removing and opening the pump

B.

- Note the axial position of the shaft coupling
- Release the stop screw

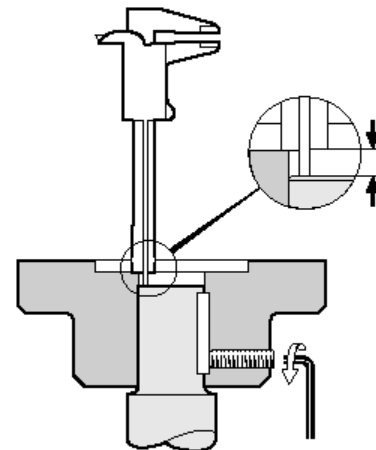

C.

- Remove the shaft coupling

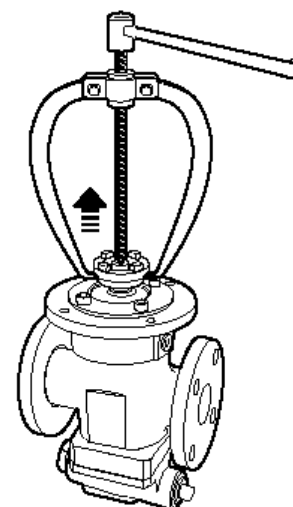

D.

- Remove the key 113

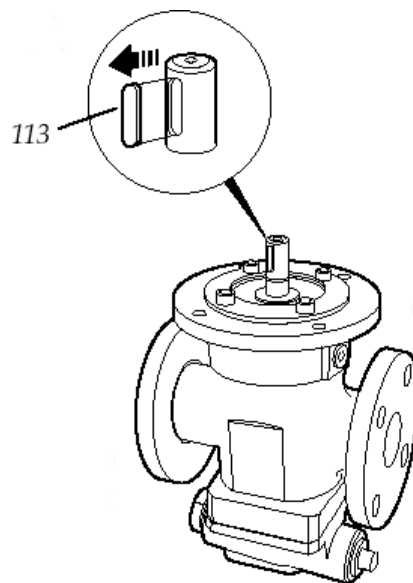
**E.**

- Remove the screws 451

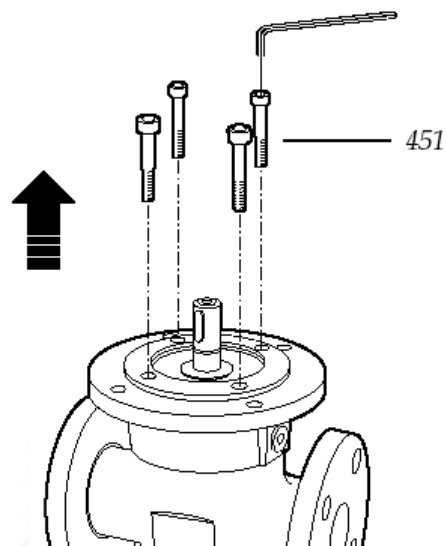
**F.**

- Remove the retaining rings 124 and 514
- Remove the support ring 124A

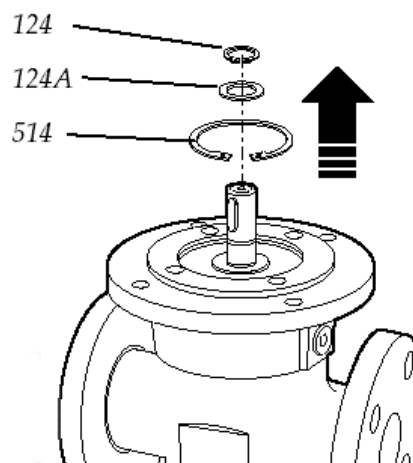

G.

- Remove the front cover 5010 with a pullet

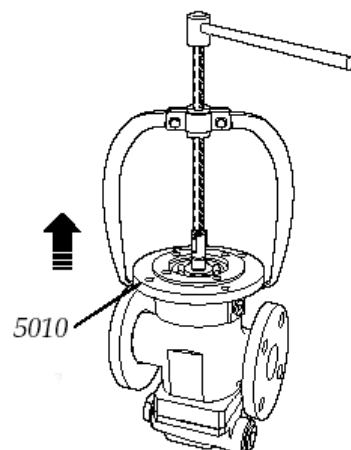

H.

- Push out the ball bearing 122 together with the distance sleeve 120. If there is tight fit use a mounting sleeve and a mallet.
- Remove the distance washer 359 and the support ring 359A.

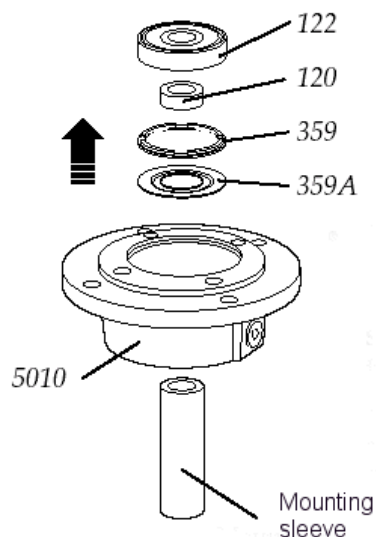

I.

- Turn the front cover 5010 upside down.
- Push out the seat from the front cover 5010
- Remove the o-ring S2
- Remove the gasket 506

The sealing surfaces of the shaft seat should not be touched with fingers.

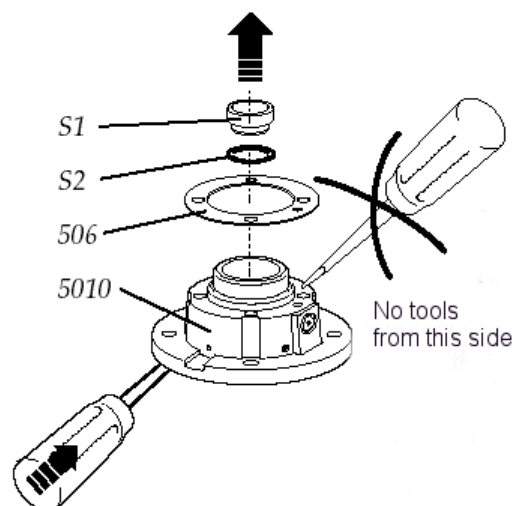

J-xVxx.

- Pull the power rotor 1020 out of the pump body and place it into the jaws of a jaw vice with soft jaws or column drilling machine.
- Push with two drivers as shown on the sketch, to remove the shaft seal.

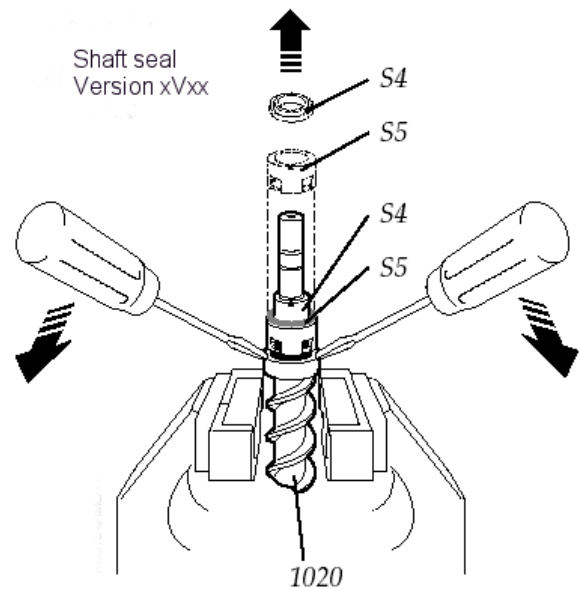

J-xTxx.

- Unscrew the seal ring carrier S5 screws and take off the seal ring carrier S5 together with the seal ring S4 and the o-ring S6

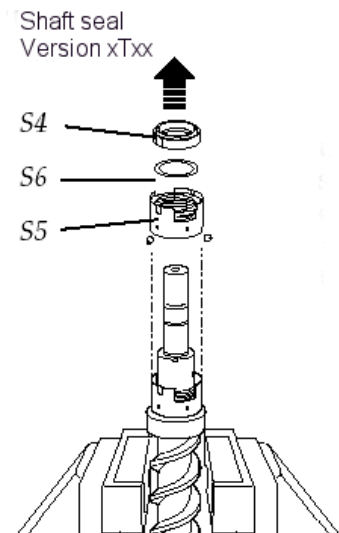

K.

- Take out the idler rotors.
- Clean all parts that are going to be used again

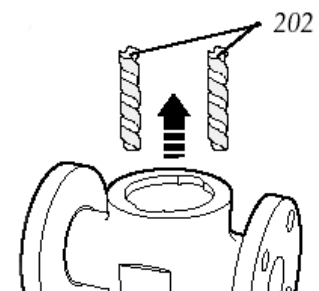

20.2.7 Re-assembly

A.

- Lubricate the idler rotors and fit them into pump.
- Lubrication groove turned downwards.

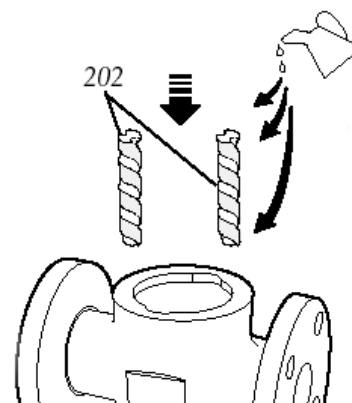

B-xVxx.

- Carefully place the power rotor 1020 into the jaw vice with soft jaws.
- Lubricate all surfaces of the power rotor 1020
- Open a package with a new sealing 509, version xVxx
- Place the bellows unit S5 on the shaft of the power rotor and press it down against the balance piston (106).

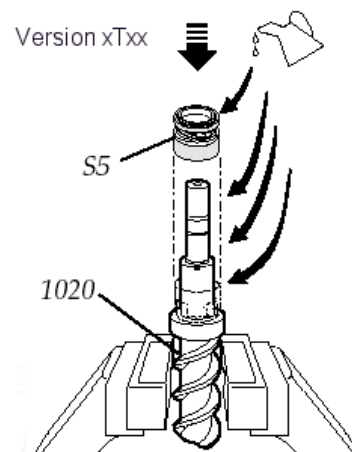

B-xTxx.

- Open a package with a new shaft seal 509 version xTxx.
- Place the seal ring carrier S5 on the shaft of the power rotor 1020 flush against the balance piston and lock it with its stop screws. Fit the o-rings S6 and the seal ring S4.

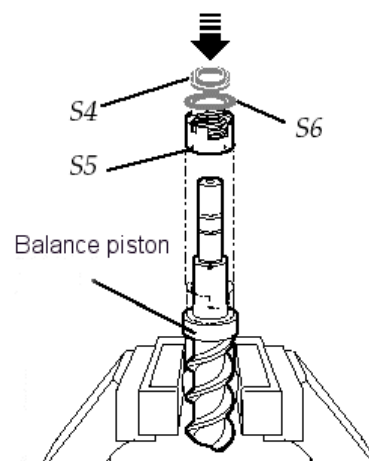

C.

- Lubricate the O-ring S2 and the recess of the front cover 5010
- Clean the sealing faces and fit the seat S1 into the front cover 5010. Mind the position of the retaining pin if applicable.

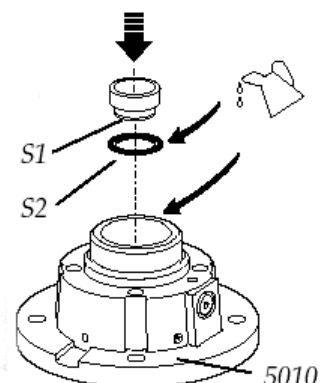

D.

- Lubricate the balance piston 106 with a thick oil (ISO VG 460).
- Fit the front cover onto the power rotor 1020 until it rests on the bellows unit S5
- Fit the support ring 359A and the distance washer 359 into the front cover. Mind the position of the distance washer 359.
- Fit the distance sleeve 120 into the front cover 5010.
- Fill the ball bearing with appropriate grease. See 19.1.5 for grease selection.
- Fit the ball bearing 122 onto the shaft.

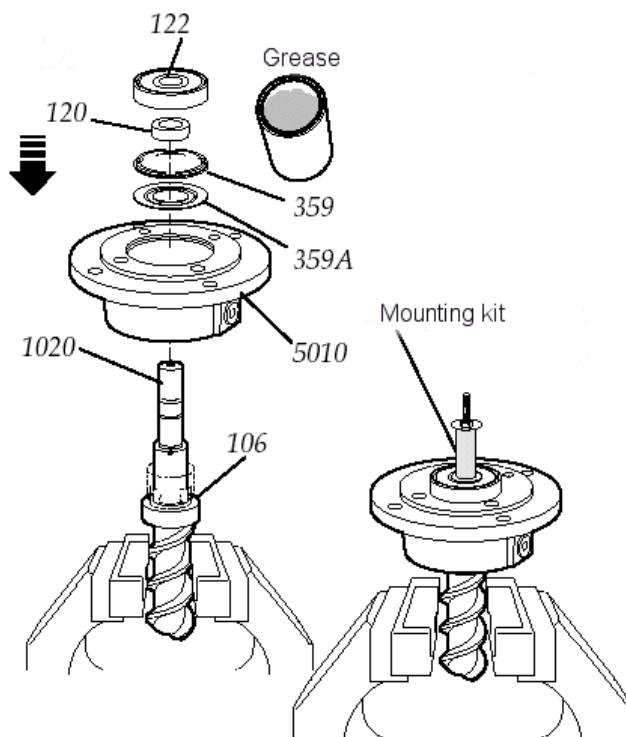

NOTE:

The open side of the bearing towards the cover

Do not use a hammer etc. as this might damage the seal and ball bearing.



E.

- Fit the support ring 124A and the retaining ring 124 on shaft.
- Fit the retaining ring 514 back in place.

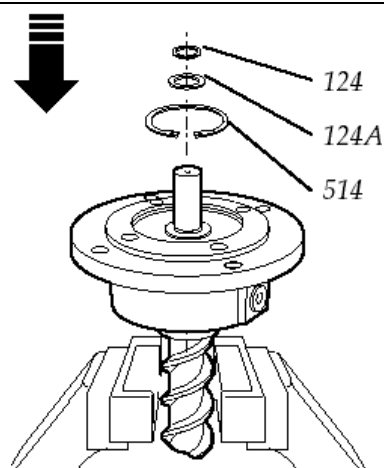

F.

- Fit the key back in position, see “Dismantling” picture C.
- Fit the shaft coupling back into place (see “Dismantling” picture B and C) with the same way used when fitting the ball bearing.

Do not use a hammer etc. as this might damage the shaft seal and ball bearing.



G.

- Remove the plug 537 and washer 537 A.
- Hold the rotor unit horizontally with the bore space completely with oil (f. ex. ISO VG 46)
- When the oil is flooding, reassemble the above parts in reverse order.
- Slowly turn the shaft a few turns to make sure it moves freely (a certain resistance from the shaft seal is normal but it must be the same during the turns).

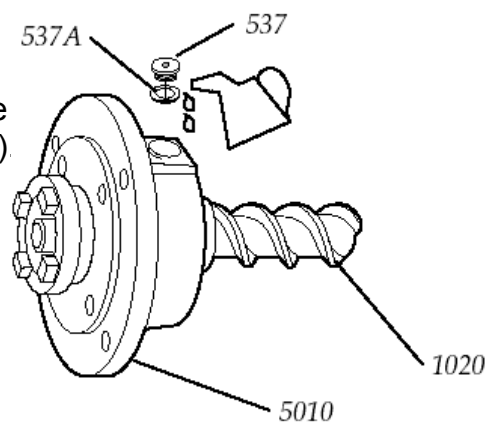

H.

- Place the gasket 506 on the pump body 401.
- Lubricate the power rotor 1020 and fit the front cover 5010 together with the rotor set into the pump body. Mind the position of the tension pin 545.
- Fit the screws 451 and tighten them crosswise.

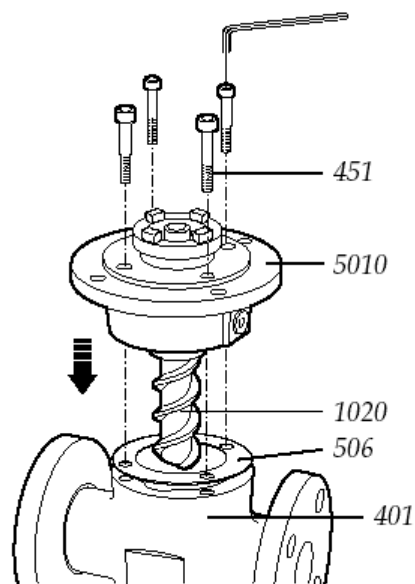
**I.**

- Put the pump back into the system and proceed according to instructions under “ Start-up”

20.3 Pressure relief valve

20.3.1 Replacement of O-ring 605:

- To avoid changing the setting of the valve, use an Allen key to prevent spindle 608 to turn. Unscrew cover 601 and pull up unit 601/608.
- Remove retaining ring 608A and pull the spindle 608 out of cover 601. Replace O-ring 605 and assemble the unit 601/608 in reverse order. Replace retaining ring 608A if necessary and washer 602.
- Fit the unit 601/608 in the valve. Make sure the 608 enters the set screw 612 and use the Allen key to prevent 608 to turn when cover 601 is tightened.

20.3.2 Replacement of Valve Element G070:

- Release the spring tension by turning the spindle 608 CCW with an Allen key. Use the Allen key to prevent spindle 608 to turn and unscrew cover 601 but do not remove it yet.
- Remove the set screw 612 by turning the spindle 608 CCW. Pull out the valve piston/spring unit 614/615.
- Fit the valve element in reverse order with a new washer 602. Turn the spindle 608 CW until the set screw leave enough room for cover 601. Use the Allen key to prevent 608 to turn further when cover 601 is tightened.
- Adjust the valve setting according to start-up Instructions.

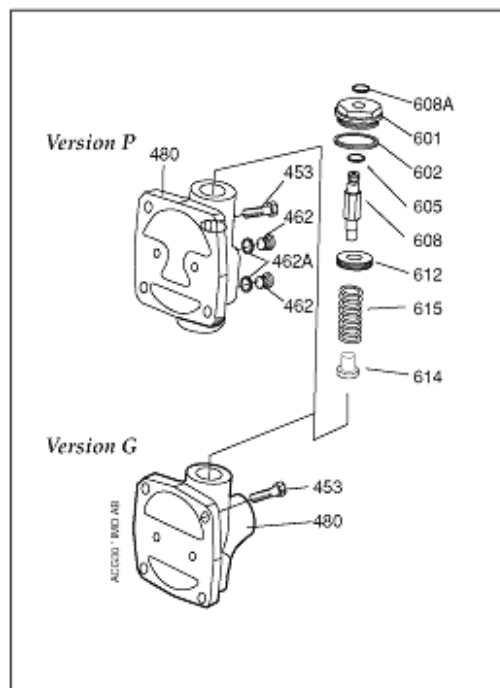

Fig. 28

20.4 Trouble shooting

Problem	Cause	What to do
Wrong direction of rotation.	Electric cables to motor wrongly connected.	Reverse the terminal connection on electric motor. Connecting and disconnecting of electric cables must be done only by personnel authorised to do such work.
The pump cannot be primed.	Wrong direction of rotation. Suction line is not open or pressure drop in the suction line is too high. Major air leakage into the suction line. The pump cannot evacuate the air through the discharge line due to excessive counter pressure.	See above. Check all components in suction line. The inlet condition should be checked with a vacuum gauge at the pump inlet. Check the suction line. See the chapter on "Deaeration".
No flow.	The pump is not primed. The pressure relief valve is set below the counter pressure.	See above. Readjust the pressure relief valve to a value above counter pressure.
Flow too low.	The pressure relief valve is set too low (Discharge pressure also low). Something is restricting the flow in the suction line (this would usually cause noise). The pumped liquid contains a significant amount of compressible gas, such as free air (this would usually cause noise).	Readjust the pressure relief Valve Check all components in the suction line (strainers, valves etc.). See the chapter on "Noise and Vibration".
Pressure too low.	The pressure relief valve is set too low. Counter pressure in the discharge line is too low due to a major leakage. The valve piston is stuck in open position. Something is restricting the flow in the suction line (this would usually cause noise). The pumped liquid contains a significant amount of compressible gas, such as free air (this would usually cause noise). A too small pump has been chosen.	Readjust the pressure relief valve. Check the components in the discharge line inclusive the recipients. Check the valve. See "Maintenance and Service" instruction for respective pump. Check all components in the suction line (strainers, valves etc.). See the chapter on "Noise and Vibration". Contact Auramarine Ltd.

Disturbance	Cause	What to do
Pressure too high.	<p>The pressure relief valve is set too high.</p> <p>The oil is too cold (or has higher viscosity than anticipated).</p> <p>Counter pressure in the discharge line is too high.</p>	<p>Readjust the pressure relief valve.</p> <p>Reduce the pressure setting until operational temperature has been reached.</p> <p>Check the discharge line.</p>
Drive motor difficult to start or tends to stop by tripping the motor overload relay.	<p>Counter pressure too high.</p> <p>Liquid too cold.</p> <p>Motor is undersized for the prevailing conditions.</p> <p>Electrical power supply faulty.</p> <p>Motor overload relay set too low or is faulty.</p> <p>Incorrect setting of Y/D starter</p>	<p>See above: Pressure too high.</p> <p>Readjust the pressure relief valve to a lower value. Thus the power consumption for the pumping is relieved and overloading due to the high viscosity may be avoided. When the liquid has reached normal temperature and thus flows easily, the relief valve is reset to normal pressure.</p> <p>Check the motor.</p> <p>Check the motor and motor connection.</p> <p>Readjust or replace the relay</p> <p>Readjust the setting of starting sequence. The time before the motor overload relay is tripped should not exceed 10-15 seconds.</p>
<p>Noise and vibrations.</p> <p>Monitor the pump function and shutdown if any sign of malfunction is noticed.</p>	<p>The flow to the pump is insufficient.</p> <p>Insufficient support of pipe work.</p> <p>Bad alignment.</p> <p>Air leakage into the suction line.</p> <p>Free air in the liquid or gas cavitation.</p> <p>Faulty electrical supply.</p>	<p>See chapter: The flow is too low.</p> <p>Check for pipe vibrations in the pump connections. Check that the pipes are sufficiently clamped.</p> <p>Check alignment.</p> <p>Check the suction line for air leakage.</p> <p>For pumps with Tuning: Adjust the Tuning. If this does not help or for pumps without Tuning: contact your Auramarine Ltd.</p> <p>Check all three phases of the supply.</p>

20.5 List of components

Valid for all pumps in sizes: ACG/UCG 045/052/060/070;
Rotor diameter and generation:K7/N7

With version codes:

N	T	B	E
	V	F	P
			G

Also valid for pump options A101, A327, A385

Example of pump designations std: ACG 045N7 NVBP

option: ACG 070N7 NVBP A101

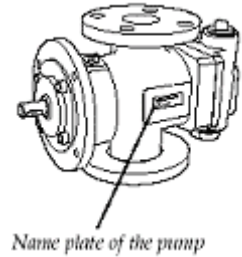

Name plate of the pump

Pos no	Denomination	Qty	Components included in spare parts sets							Notes	Explanations
			G011	G012	G050	G053	G054	G057	G070		
1010	Power rotor CCW-rot	1	x				(x)				CCW-rotation option
1020	Power rotor CW-rot	1		x			x				G012:Rotor set
106	Balancing piston	1	x	x			x			5	CW-rotation(std)
113	Shaft key	1	x	x			x				G050 shaft seal
120	Distance sleeve	1									
122	Ball bearing	1				x	x				
124	Retaining ring	1				x	x	x			
124A	Support ring	1				x	x	x			G053:Minor kit
201	Idler rotor CCW-rot	2	x				(x)				(G050+G057)+122
202	Idler rotor CW-rot	2		x			x				G054 Major kit consisting of:
359	Distance washer	1									G053+G012(G011)
359A	Support ring	1				x	x	x			
401	Pump body	1									G057: Joint kit
424	Sleeve	1								4	
424A	Washer	1								4	G070: Valve element
429	Spindle	1								4	
437	O-ring	1								4	ACG Pump with DIN flanges
440	Return valve	1									
451	Screw	4/6									
453	Screw	4									UCG Pump with ANSI
462	Plug	2								1	flanges
462A	Sealing washer	2				x	x	x		1	
473	Grease nipple	1									A101:CCW
473A	Grease nipple cover	1									
480	Valve housing	1								2	A327: With Tuning
5010	Front cover	1									
502	Tension pin	1								6	A385:CCW and Tuning
502A	Plug	1								6	
506	Gasket	1				x	x	x			Notes:
509	Shaft seal	1			x	x	x	x			1)Excluded in xxxG
514	Retaining ring	1				x	x	x			2)Excluded in xxxE
537	Plug	2									3)Valid for xxxE
537A	Sealing washer	2				x	x	x			4)Valid for pump option A327
551	Rear cover	1								3	5)Included in item 1020
556	Gasket	1				x	x	x			or 1010
601	Valve cover	1							x	2,7	6)Included in item 5010
602	Sealing washer	1				x	x	x	x	2	7)Only sold as G070
605	O-ring	1							x	2	
608	Valve spindle	1				x	x	x	x	2,7	
608A	Retaining ring	1							x	2	
612	Set screw	1							x	2,7	
614	Valve piston	1							x	2,7	
615	Valve spring	1							x	2	

ACG/UCG xxBE/BP/BG

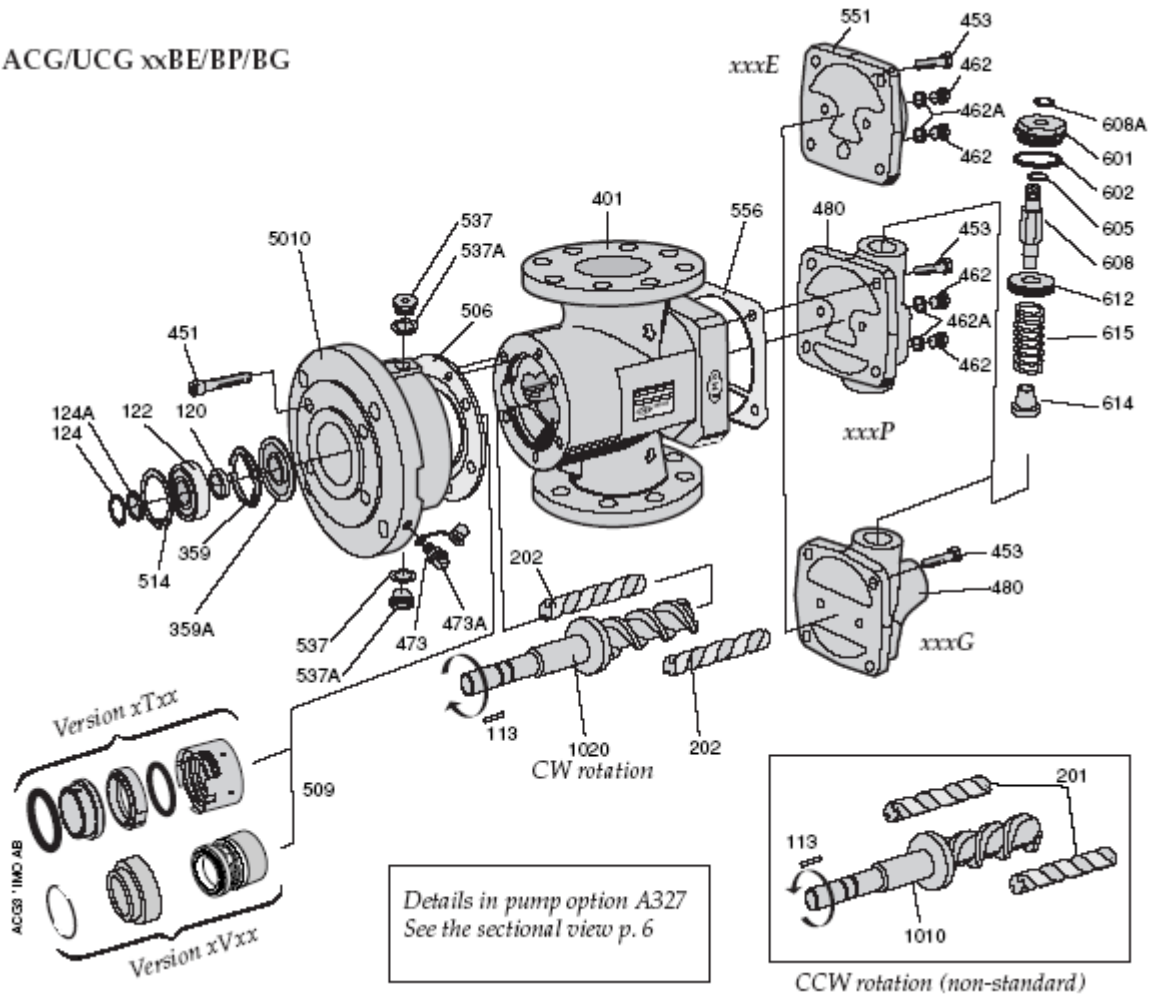

20.5.1 Spare part sets

Pos No	Spare Part sets	Part numbers, sizes			
		045	052	060	070
G012	Rotor set CW-rotation(std)				
	Normal lead -pump version N7	178913	179507	179515	179523
	Low lead -pump version K7	187542	187559	187567	197575
G011	Rotor set CCW-rotation(non-std)				
	Normal lead -version N7	186478	186486	186494	186502
	Low lead -version K7	189641	189642	189643	189644
G050	Complete shaft seal- version code xVxx	190335	190336	190338	190340
	Complete shaft seal- version code xTxx	174094	174102	174110	174128
G053	Minor kit -version code xVxx	191241	191243	191245	191247
	Minor kit -version code xTxx	191242	191244	191246	191248
G054	Major kit=G012(G011)+G053	-	-	-	-
G057	Joint kit	191237	191238	191239	191240
G070	Valve Element -version code xxxP/G	191250	191250	191251	191251
122	Ball-bearing	X	X	X	x

21 HOMOGENIZER, TYPE LEMAG SLASHPOL H

21.1 Start-up

- Check rotation direction of motor once the unit has been wired to the electric cabinet.
- Open fuel pipe system through the unit in order to heat up the homogenizer to minimum 50 -60°C before starting
- Press start button on electric cabinet and observe first start.
- Ensure there are no irregularities, e.g. extensive mechanical noises, vibrations or electrical overload.
- Once the homogenizer is in normal operation no special requirements are to be observed for continuous operation.

21.2 Operation

Check operation of the homogenizer, operational pressure and operational temperature regularly.



Be aware of hot surfaces during operation.

Avoid overheating the homogenizer over 150°C to prevent damages of slide bearing inside the magnetic coupling drive.

Before taking out of operation purge the homogenizer with diesel oil to prevent blockages.

The fuel oil will also pass the homogenizer when the unit is switched off. The by-pass system must not be used in general.

The magnetic coupling drive eliminates all problems occurred with the old mechanical seal design and hereby reduces the need for maintainance.

The magnetic coupling creates a hermetically sealed homogenizing chamber with virtually no possibility of fuel leakage. The silicon-carbide sleeve-type bearings (diamond hardness with 2600 vicker) inside the magnetic coupling will be lubricated by homogenized fuel flowing through them and therefore no external lubrication is needed.

21.3 Maintenance

The homogenizer is maintenance free.



Do not carry out any service to the unit in explosive areas!

Be aware of hot surfaces during operation with HFO.

Prior any service, stop the unit and switch off main switch at electric cabinet.

Open by-pass line in fuel oil system first and then close inlet and outlet valves of the unit to prevent fuel flow interruption.

Before any change or repair of the unit or electric components, please, contact Auramarine Ltd.

In case of maintenance and repair, purge the unit with diesel oil or similar to prevent blockage of hardened HFO inside the homogenizing chamber.

Do not open the homogenizer or change any clearance of milling parts or slide bearing without prior consultation with manufacturer!

21.4 Spare parts





All spare parts will be delivered along with the specific installation and mounting instructions.

type A = 3 m³/h at 36 cst

type B = 5 m³/h at 36 cst

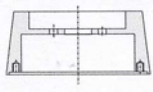
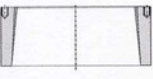
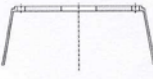
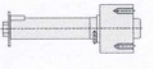
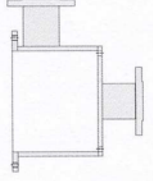
type C = 8 m³/h at 36 cst

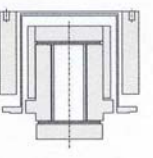
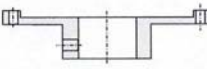
type D = 12 m³/h at 36 cst

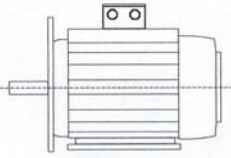
Component	Drawing of component	part number
Rotor		HOM 001 A*...
Stator		HOM 002 A*...
Outlet disc		HOM 003 A*...
shaft		HOM 004 A*...
housing		HOM 005 A*...
Connecting flange		HOM 006 A*...
Magnetic coupling drive with sleeve bearings		HOM 007 A*...
Coupling support		HOM 008 A*...
Support foot		HOM 011 A*...
E-Motor		HOM 012 A*...

A* - sample for type A only, for other types please use the corresponding letter A, B, C or D.

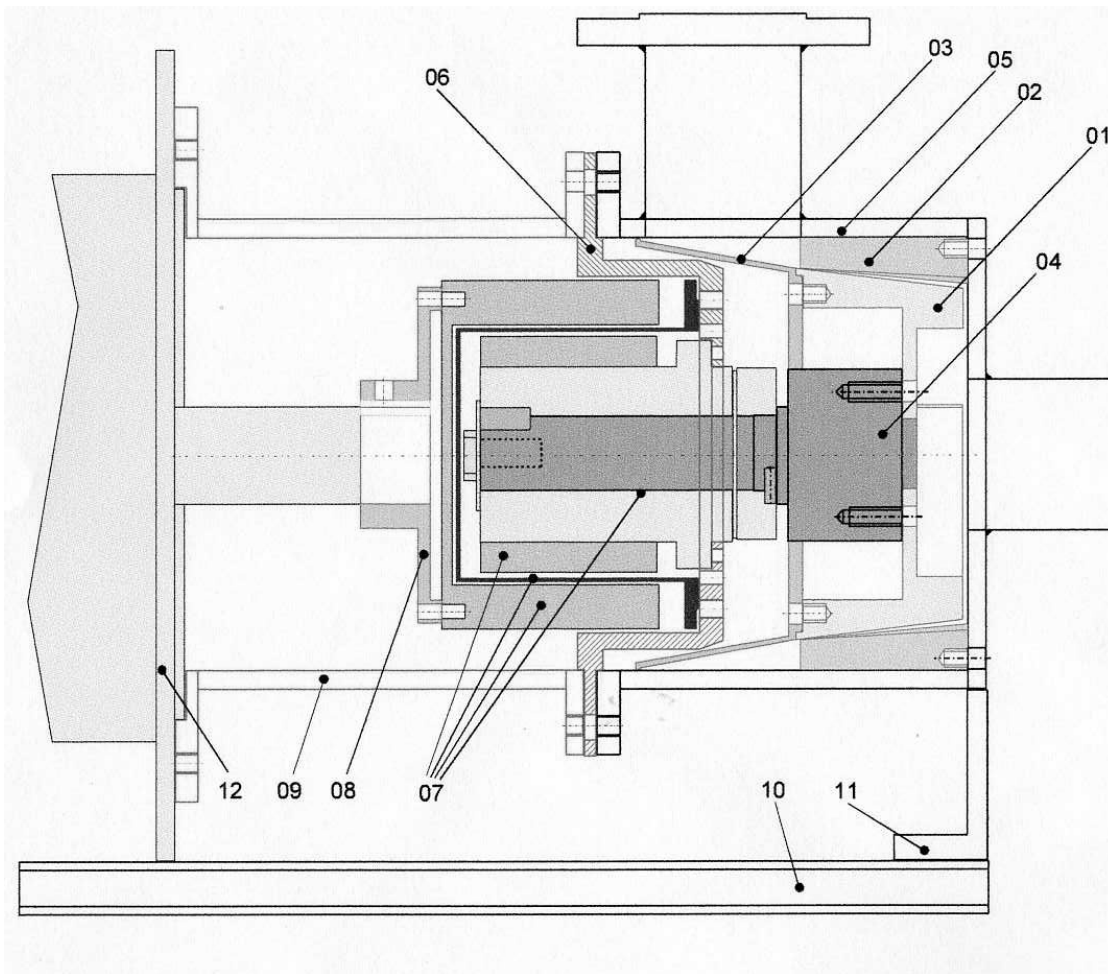

- 01 rotor
- 02 stator
- 03 outlet disc
- 04 shaft
- 05 housing
- 06 connecting flange
- 07 magnetic coupling drive, sleeve bearing
- 08 coupling support
- 09 connecting bracket
- 10 fundament
- 11 support foot
- 12 electrical motor

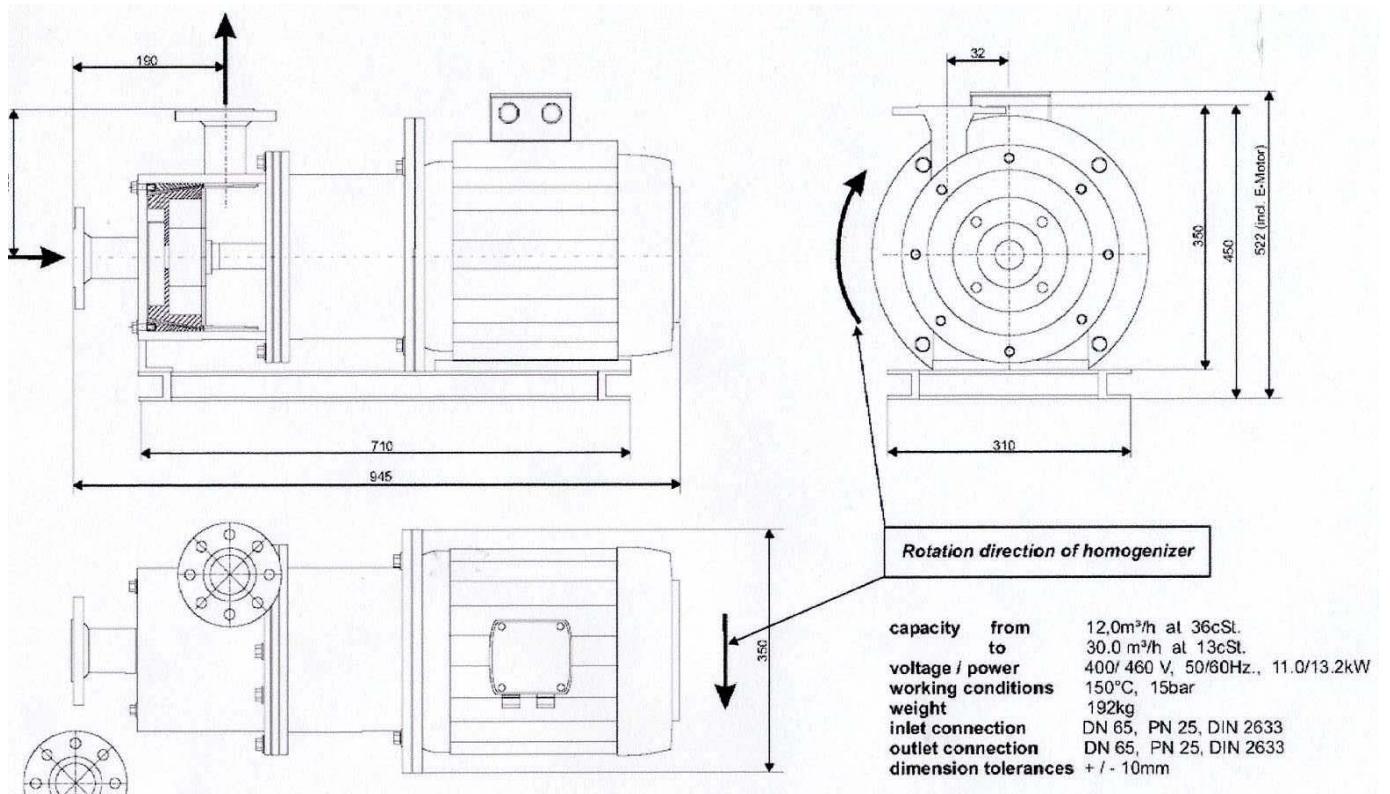

Wiring diagram

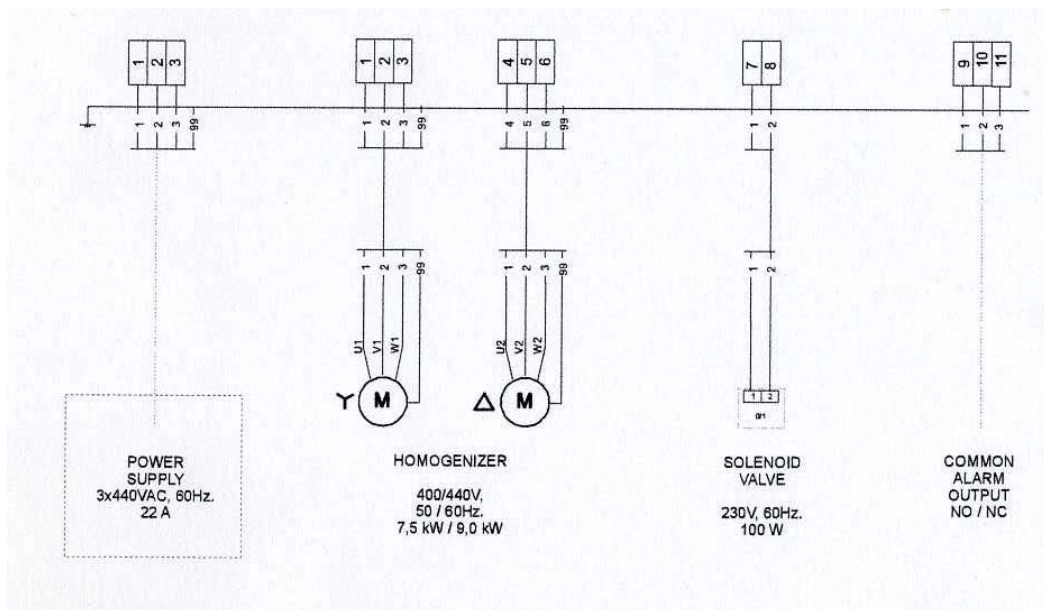
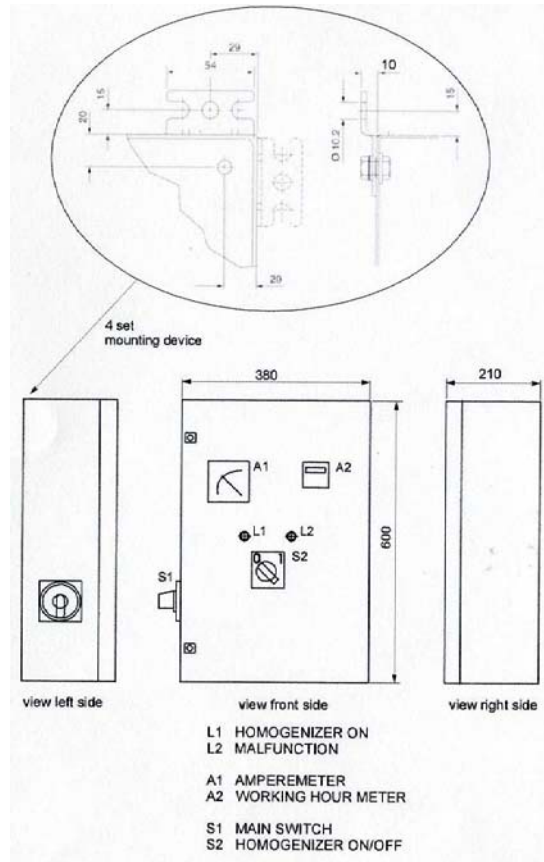

22 PRESSURE LIMITING VALVE SPVF



Personnel who are responsible for the installation, operation and the repair of the pressure limiting valve, must possess an appropriate qualification; this can have been obtained through training or relevant instruction. Such personnel must be acquainted with the contents of this instruction.

During all work, the prevailing national regulations relating to accident prevention and safety in the work place and, where appropriate, internal regulations of the operator, must be adhered to, even where these are not named in this introduction.

During all work and prior to installation, the connecting pipelines must be de-pressurised!

The operator must ensure that these operating instructions are accessible to the personnel concerned at all times.

Servicing and adjustments to the pressure limiting valve, which require it to be dismantled, are only to be carried out by trained and appropriately qualified personnel.

When dismantling the pressure-limiting valve, the components must be directly protected from damage and soiling.

Fluids emerging from the valve must be collected and disposed of in such a way that there is no danger to personnel or to the environment. The currently applicable regulations must be observed

22.1 Description of operation

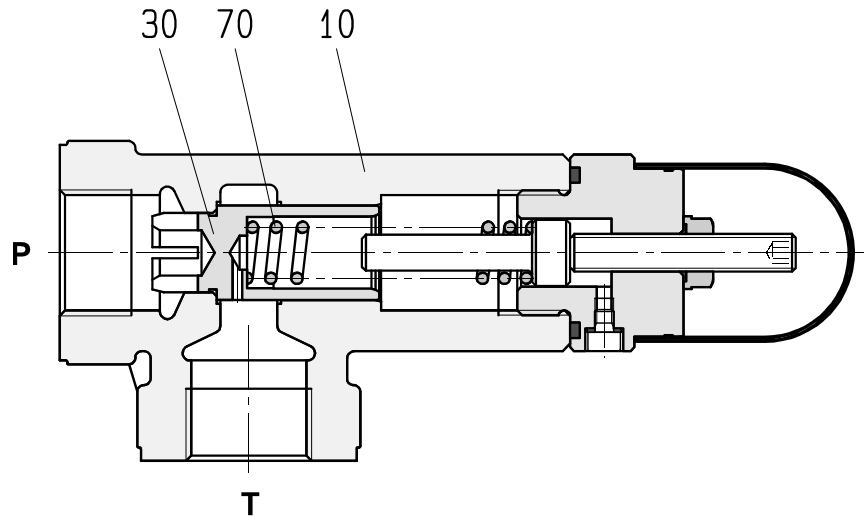

The directly controlled pressure-limiting valves are used to protect low-pressure circuits, up to a maximum pressure of 20 bar (SPVF 10, p max. 30 bar).

In a cast hydraulic housing 10, a valve spool 30 seals the pressure chamber P from the reservoir connection T, when acted on by the pressure spring 70. When the set pressure is reached, the valve spool 30 opens to create a connection between P and T. As the pressure in P falls below the set pressure value, the valve closes.

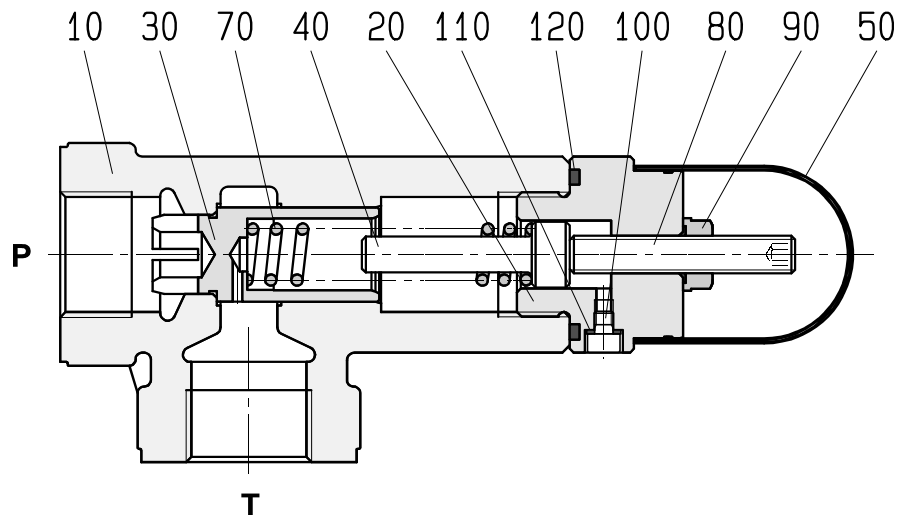

22.2 Constructions and spares

Item	Description	Item	Description	Item	Description
10	Housing	50	Protecting cap	100	Vent (bleed)
20	Plug	70	Pressure cap	110	Flat seal
30	Valve spool	80	Threaded rod	120	O-Ring
40	Spring guide	90	Hexagonal nut		

22.3 Adjustment

The pressure limiting valve is set to the pressure required by the customer. It may be necessary to carry out a check on the pressure setting during commissioning, since different flow rates, oil viscosities and pipe lengths can affect the response value. In such cases, a manometer should be connected directly to the valve oil pressure connection. Their characteristics are such that each of the four pressure springs available is only suitable for a limited range of setting pressures.

The pressure setting adjustment is made by removing the protecting cap 50 and loosening the hexagonal headed nut 90 on the threaded rod 80, by means of an internal hexagon ring spanner.

Rotation to the right increases the pressure setting, rotation to the left decreases the pressure. On achieving the desired pressure setting, the hexagon headed nut 90 must be tightened and the cap 50.

22.4 Venting

Pressure limiting valves only operate correctly when all the voids within the valve are filled with hydraulic fluid. If the installed attitude is incorrect, air may collect in the spring chambers and lead to hydraulic shock. In these circumstances the valve must be ventilated (bled). This is achieved by unscrewing the vent screw 100 through one turn. Venting should occur at low pressure and is complete when oil is discharged free of air bubbles. After venting, the vent screw is tightened again.

23 BALL VALVES, TYPES N2, N8 AND N9

23.1 Operation



During operation the ball valves must be in either complete OPEN or CLOSED position in order to ensure their smooth and efficient working and long duration of seats. Leaving the ball in half open position could eventually cause damage to the soft seats.

23.1.1 Manual operation

The opening and closing of the valve is done by turning the handle a quarter turn (90°)

- a.) valve is in open position when the handle is in line with the valve and pipe line
- b.) valve is in closed position when the handle is across the pipe line

23.1.2 Automated operation

Valve can be automatically operated by: A pneumatic actuators (DA or SR), B hydraulic actuators, C electrical actuators, D gear box (manually operated). In this case no stop is fitted on the valve since it is normally a part of the actuator.

23.2 Maintenance



Before starting the maintenance, be sure that all pressure on the pipe is relieved.

Open and close the ball valve at least once to release the pressure completely also from the valve body.

- the ball valves if correctly used, normally do not need any internal lubrication and maintenance. However, when necessary, ball , or seats can be replaced only by relatively qualified personnel following the instruction of the manual without needs to use any machinery
- for further information about the recommended spare parts please check drawing and contact Auramarine Ltd.

23.2.1 Steam leakage

If leakage is evident on stem packing area, it can be eliminated by increasing the tightness of the lock nut 2B. In case leakage is still persisting the replacement of the stem packing 3 is recommended. For handle nut and lock nut (2A-2B) tightness see table.

23.2.2 Body seals leakage

Check for the tightness of the body bolts 16 according to table in case it is still leaking, it is necessary to replace the body seals 11-18.

23.2.3 In line or seats leakage

Check that valve is in fully closed position if so and the leakage is persisting the valve must be disassembled to replace damaged parts.



Safety precaution before removing the ball valve line for disassembly

- a.) **check that all pressure is exhausted from the line (upstream and downstream) and half open the ball to ensure that no pressure is trapped in the body cavity. In other words it must be drained of all fluid/gas and pressure.**
- b.) **remove the valve from the line and cycle valve at minimum 1 full cycle to ensure that any pressure trapped is released.**
- c.) **If the fluid in the line and into the valve is toxic, inflammable, corrosive or damaging for any other reason, it is advisable to take following precaution during the valve repairing:**
 - **use protective eye mask or glasses**
 - **use gloves, overalls and suitable footwear**
 - **ensure that running water and fire extinguisher is easily available at any moment**

23.3 Valve disassembly to inspect and/or replace body seals, seats, packing and ball

- a.) set the valve in open position and take out all body bolts 16 and complete body from end connections
- b.) close the ball and remove seats 10, ball 9 and body seals 11-18, be careful not to damage the ball
- c.) remove handle nut A2, name plate, handle 1, stop washer 17, lock nut 2B, spring washer 4, gland packing 6
- d.) push the stem 5 into the body 12. Remove packing rings 7 from body and O'ring 8 plus thrust washer 7 from stem.

23.4 Inspection and replacement

With the valve completely disassembled, clean and examine all the following components:

- a.) surface of the ball: any surface defect, particularly in the seating area will be extremely detrimental to the performance of the valve and therefore the ball should be replaced if found defective.
- b.) seats: replacement or seats is recommended
- c.) stem seals and body seals: also to be discarded and replaced by a new one
- d.) remaining components of the valve: after cleaning it is required a careful examination for wear, corrosion and mechanical damages particularly on threaded components. If components are found defective they should be replaced.

23.5 Re-assembly

Clean inside of body and stem housing. A light oil/grease compatible with line fluid can be used on ball, seats and stem surfaces.

23.5.1 Stem re-assembly

- a.) replace thrust washer and O'ring 7-8 and then insert the stem from the inside body
- b.) install the packing ring 3, gland packing 6, spring washer 4 and lock nut 2B and tighten. To avoid rotation of stem, apply temporarily the handle.
- c.) install stop washer 17, handle 1, name plate, handle nut 2A and tighten (see values given in the table)

23.5.2 Ball, seats and seals re-assembly, types N8 and N9

- a.) insert the fourth seat into the body and then insert the ball
- b.) insert the seat-retainer 23 together with the seat 10 and retainer-seal 18 and then repeat the operations on the opposite way. **ONLY NOW** you can assemble the n. 2 end-caps and tighten.
- c.) repeat the operations on the third way (third and fourth in case of 4 ways).

23.5.3 Ball, seats and seals re-assembly, type N2

- a) place the stem in closed position and insert the ball in the same position
- b) rotated in open position and then insert the seats and body seals
- c) insert the center-piece between the end-caps and tighten bolts and nuts firmly (see values given in table)

23.6 Testing

- a.) after having completed the re-assembly check for the manoeuvrability of the valve and make sure that ball rotates freely
- b.) if facilities are available, test the ball valve to the appropriate specification

23.7 Automated ball valves

- a.) if the valve is automated, reinstall the actuator and please note that the handle is not used. If necessary, reset the stops. First set- the valve in open position and check that ball is fully open. Second set- the valve in closed position and check, adjusting if necessary, for the best closure.
- b.) **CAUTION! Valves with electrical actuators should be tested starting from valve in: HALF OPEN - HALF CLOSED POSITION. This is to ensure that electrical connection is all right and rotation is correct. In case of wrong position switch off electrical actuator immediately and change the direction. Limit and torque switches are ineffective if rotation is wrong.**

23.8 Tightness values for handle nut 2A-2B and body bolts 16, types N8 and N9

VALVE SIZE		HANDLE NUT 2 A LOCK NUT 2 B			BODY BOLTS PART NO. 16		
FULL BORE	RED BORE	DIMENSION	NM	INCH LBS	DIMENSION	NM	INCH LBS
1/4	/	M 10X1	8	70	M8X17	35	310
3/8	1/2	M 10X1	8	70	M8X17	35	310
1/2	3/4	M 10X1	8	70	M8X17	35	310
3/4	1	M 12X1.25	15	130	M10X22	50	440
1	1 1/4	M 12X1.25	15	130	M10X22	50	440
1 1/4	1 1/2	M15X1.5	25	220	M12X30	70	620
1 1/2	2	M15X1.5	25	220	M12X30	70	620
2	2 1/2	M15X1.5	25	220	M12X30	70	620
2 1/2	3	M22X1.5	40	355	M12X35	70	620
3	4	M24X2	50	440	M12X35	70	620

23.9 Tightness values for handle nut 2A-2B and body bolts 16, type N2

VALVE SIZE		HANDLE NUT 2 A LOCK NUT 2 B			BODY BOLTS PART NO. 16 AND NUTS PART NO 19		
FULL BORE	RED BORE	DIMENSION	NM	INCH LBS	DIMENSION	NM	INCH LBS
1/4	/	M 10X1	8	70	M8X47	35	310
3/8	1/2	M 10X1	8	70	M8X47	35	310
1/2	3/4	M 10X1	8	70	M8X51	35	310
3/4	1	M 12X1.25	15	130	M10X64	50	440
1	1 1/4	M 12X1.25	15	130	M10X75	50	440
1 1/4	1 1/2	M15X1.5	25	220	M12X88	70	620
1 1/2	2	M15X1.5	25	220	M12X95	70	620

23.10 Storage

Valves to be stored for a long time shall be checked by the quality control personnel every 6 months; every 3 months when valves are actuated.

Maintenance during storage period:

- a.) internal surface must be inspected to check complete dust or other foreign parts absence
- b.) old rust or any dust must be removed by wiping with proper solvent
- c.) after cleaning, ball valves must be lubricated by using an adequate lubricant
- d.) ball valves must be operated for a least 2 complete cycles

23.11 Spare parts

N8 and N9

Item NO	Q.TY	PART NAME
1	1	Handle
**2a	1	Handle nut
**2b	1	Lock nut
*3	1	Packing ring
**4	2	Spring washer
**5	1	Antistatic stem
6	1	Gland packing
*7	1	Thrust washer
*8	1	O-ring stem
**9	1	Ball
*10	4	Seats
*11	3-4	Body seal
12	1	Body
13	3-4	End connections
14	1	Stop-pin
16	16-20	Bolts
**17	1	Stop washer
*18	3-4	Retainer seal
23	3-4	Seat retainer

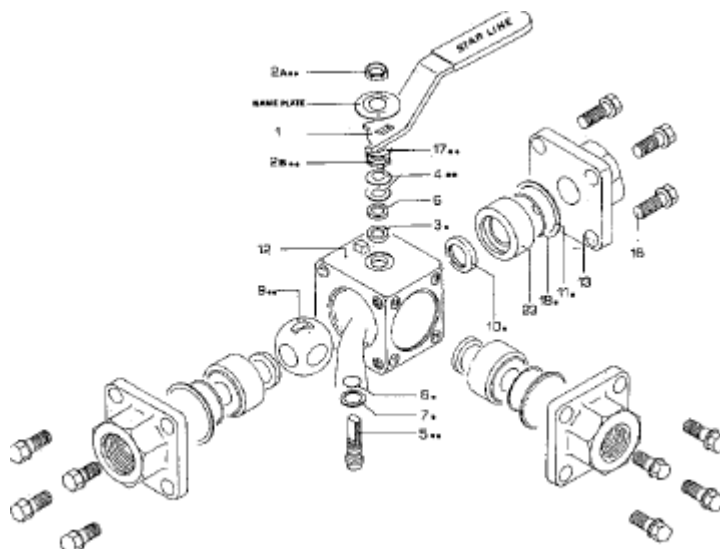

N2

Item NO	Q.TY	PART NAME
1	1	Handle
**2a	2	Nut
*3	1	Packing ring
**4	2	Spring washer
**5	1	Antistatic stem
6	1	Gland packing
*7	1	Thrust washer
*8	1	O-ring stem
**9	1	Ball
*10	2	Seats
*11	2	Body seal
12	1	Body
13	2	End connections
14	1	Stop-pin
16	4	Bolts
**17	1	Stop washer
*18	2	Body seal
19	4	Nuts

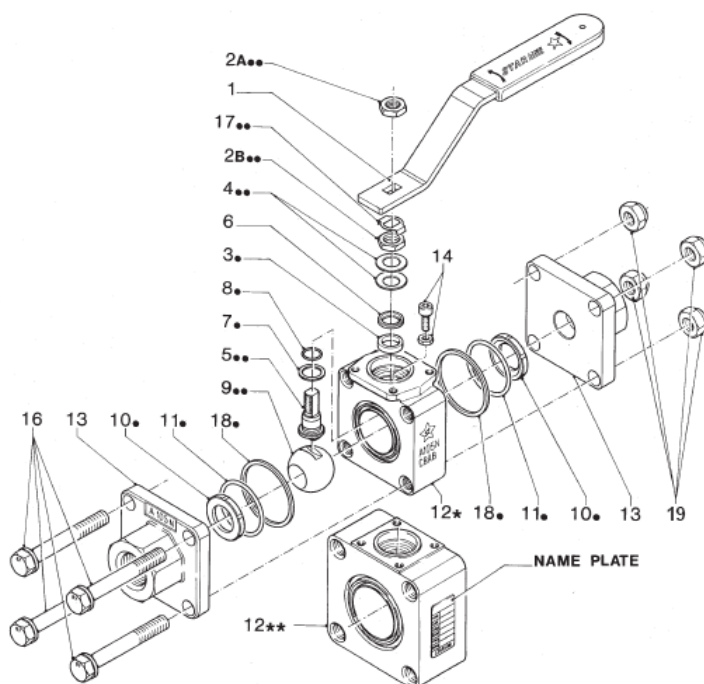

* suggested materials after 2 years service
** suggested materials after 5 years service

24 VALVE, SERIES 776000

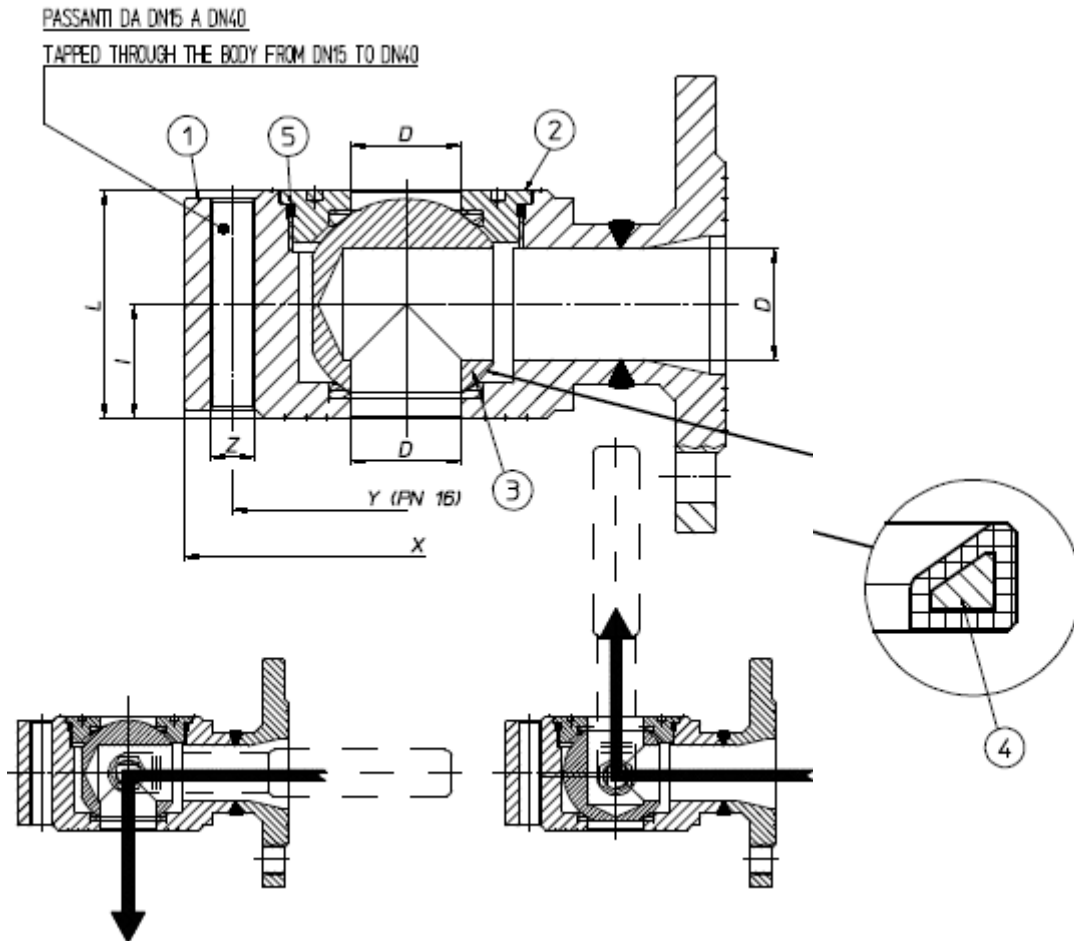

- 1 Body
- 2 End connection
- 3 Ball
- 4 Ball seats
- 5 Rings
- 6 Thrust washer
- 7 Ring
- 8 Stem seat
- 9 Packing gland
- 10 End stop
- 11 Spring washer
- 12 Nut
- 13 Stem
- 14 Handle

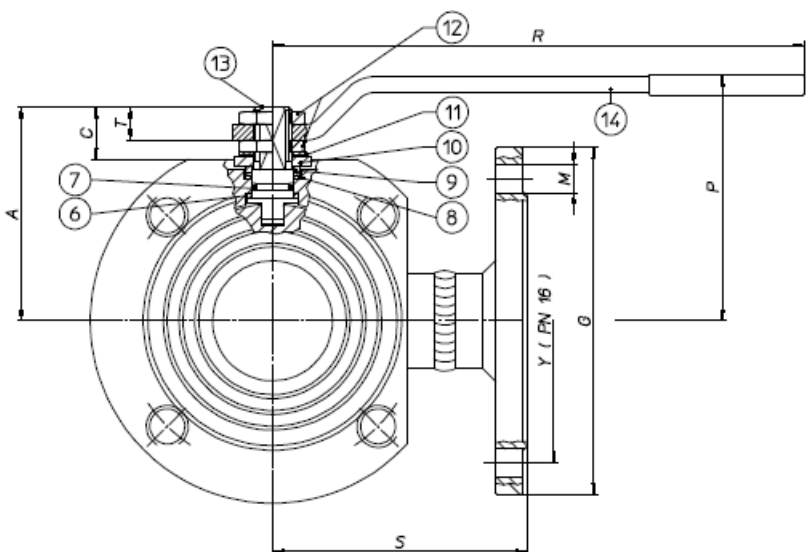

25 SWITCHBOX, SERIES W AUTOMAX

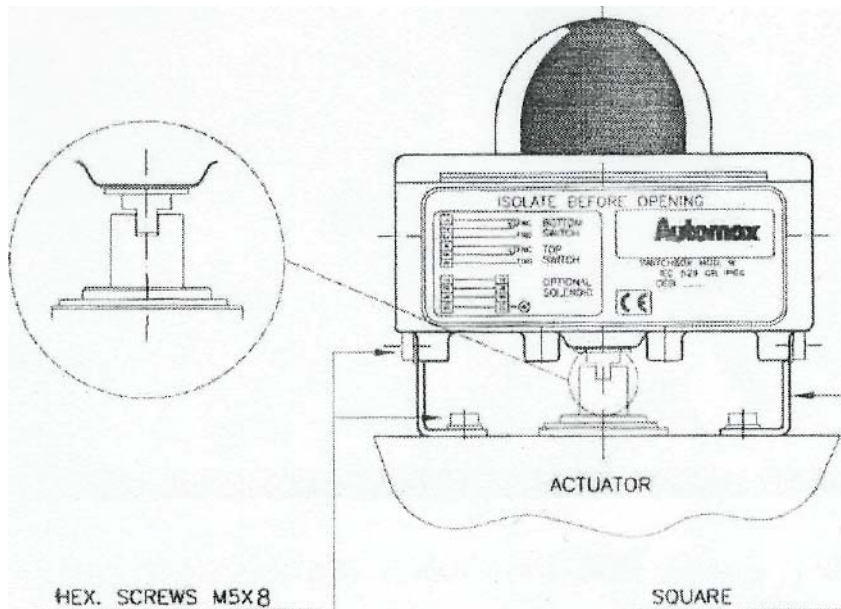

25.1 Adjusting limit switches



Disconnect power before removing the cover!

Make the actuator/valve system rotate CW, then adjust as follows

- Pull the BOTTOM cam to disengage it from splines, then rotate it CW just until switch trips. Reengage the cam with splines.
- Make the actuator/valve system rotate CCW.
- Push the TOP cam to disengage it from splines, then rotate it CCW just until switch trips. Reengage the cam with splines.

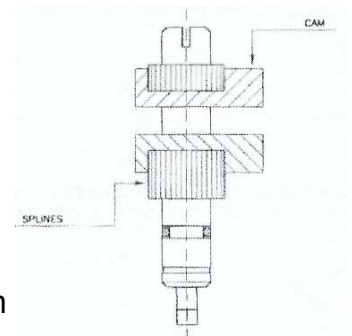

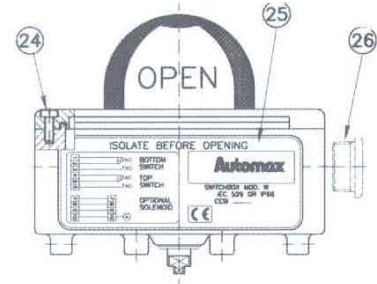
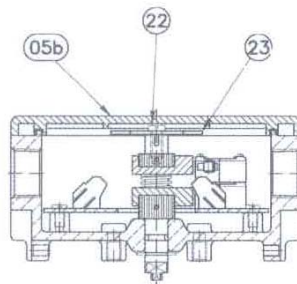
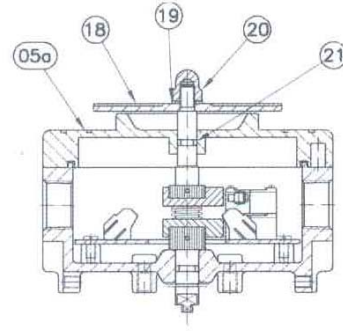
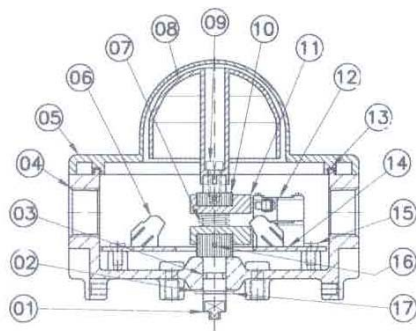

- 1 cam shaft
- 2 washer
- 3 lower shaft O-ring
- 4 body
- 5 pharos cover
- 5a metal cover
- 5b flat cover
- 6 terminal strip
- 7 cam springs
- 8 pharos rotor
- 9 pharos rotor screw
- 10 shaft retainers
- 11 cams
- 12 limit switch
- 13 cover O-ring
- 14 printed circuit board
- 15 PCB screw
- 16 elastic pins
- 17 shaft snap ring
- 18 metal position indicator
- 19 washer
- 20 blind nut
- 21 upper shft O-ring
- 22 position indicator screw
- 23 position indicator
- 24 enclosure screw
- 25 identification nameplate
- 26 plug PG 13.5

26 CONTROL VALVE, TYPES BR440-446



Before putting a new plant into operation or restarting a plant after repairs or modification, always make sure that:

- **All installation and assembly work has been completed!**
- **The personnel is qualified**
- **The valve is in the correct position for its function!**
- **Existing guards have been attached and in good order.**

26.1 Maintenance

Maintenance and maintenance intervals have to be defined by the operator according to the service conditions (see TRB 700).

When dismantling the valve the following points must be observed beside the general principals rules and TRB 700 governing the assembly work:

- pipe system must be pressureless
- medium must be cool
- plant must be drained
- piping system is purged in case of aggressive or caustic media
- the assembly work is performed only by qualified personnel

26.1.1 Packings with PTFE V-ring unit

PTFE V-ring unit consists of 1 backing ring, 4 sealing rings, 1 cover ring

Owing to the installed compression spring, this spindle packing is self-adjusting. If the spindle starts leaking, the ring pack is worn out and must be replaced.

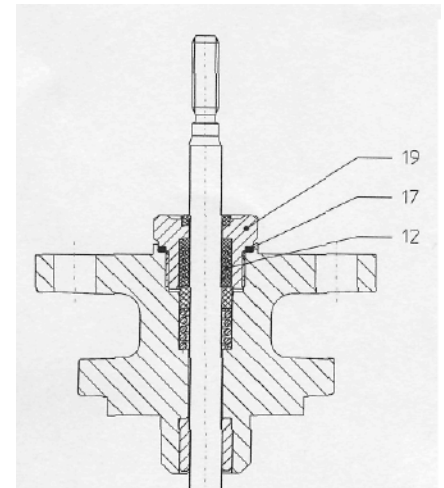

Replacing the PTFE V-rings:

- Remove the actuator (see operating instructions for actuator).
- When replacing PTFE V-ring unit (12), make sure that the parts are installed in the correct order and positions.
- Damaged spindles must also be replaced (see chapter Replacing the plug, spindle and seating for instructions) since a new ring pack will soon start leaking again with a damaged spindle.

NOTE: Gasket (17) must be replaced.

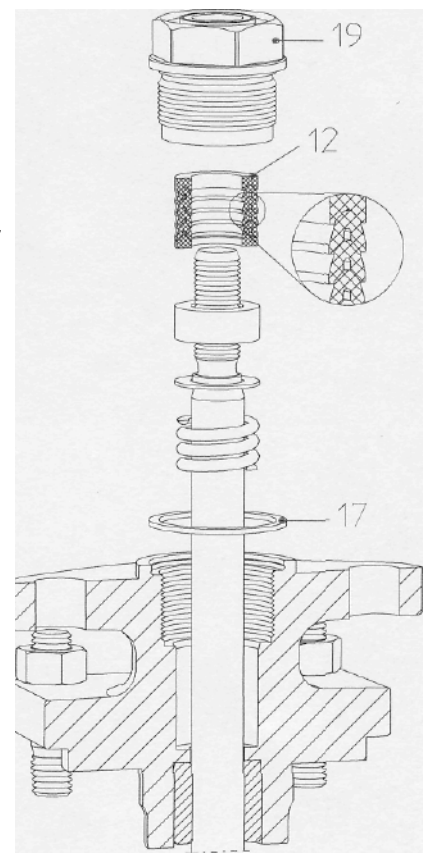

26.1.2 Stuffing box packings

Stuffing box packings require maintenance. If leaks develop, immediately tighten the screw joint (25) gradually until the packing stops leaking. The service life of stuffing box packings (23) can be increased by checking regularly leakage. If leaks can no longer be stopped by tightening the nuts, a new packing ring must be inserted into the gland.

Replacing a stuffing box packing:

- Insert the new packing ring
- If a split packing ring is used, cut with a chamfer
- Damaged spindles must also be replaced since a new ring pack will soon start leaking again with a damaged spindle.

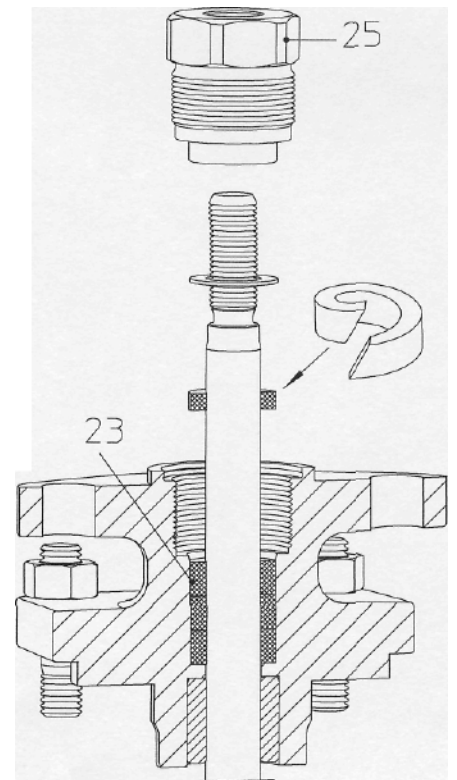
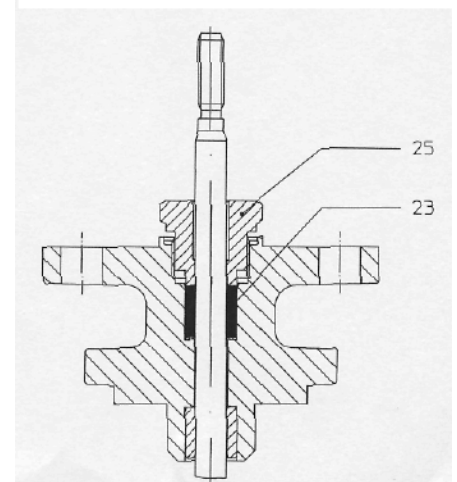

26.1.3 Bellow Seal

If the spindle leaks, the bellow seal is defective. The leak can initially be stopped by tightening the screw joint (20.17).

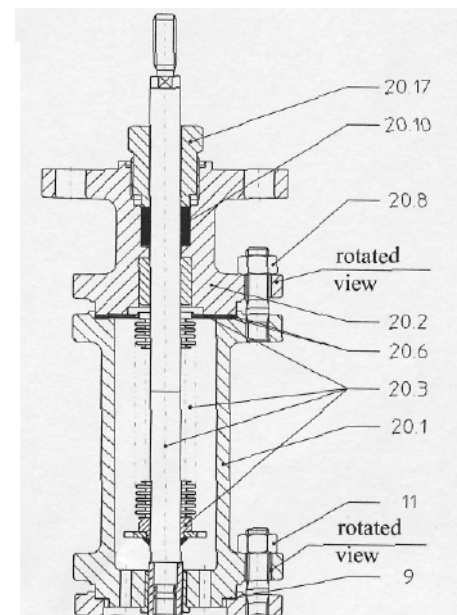

Replacing the bellow seal:

- Remove the actuator (see operating instructions for actuator).
- Slacken the screw joint (20.17) by about one turn.
- Remove the bellows housing by unscrewing the nuts (11).
- Remove the plug
- Detach the mounting bonnet (20.2) after unscrewing the nuts (20.8).
- Extract the spindle from the bellows housing.
- Drill new spindle with plug.
- Replace 2 seals (20.6) and 1 seal (9).
- Assemble in the reverse order. Screw on the nuts (11, 20.8) and tighten them crosswise (See page 9 for tightening torque's).
(The spindle can only be replaced complete with bellows.)

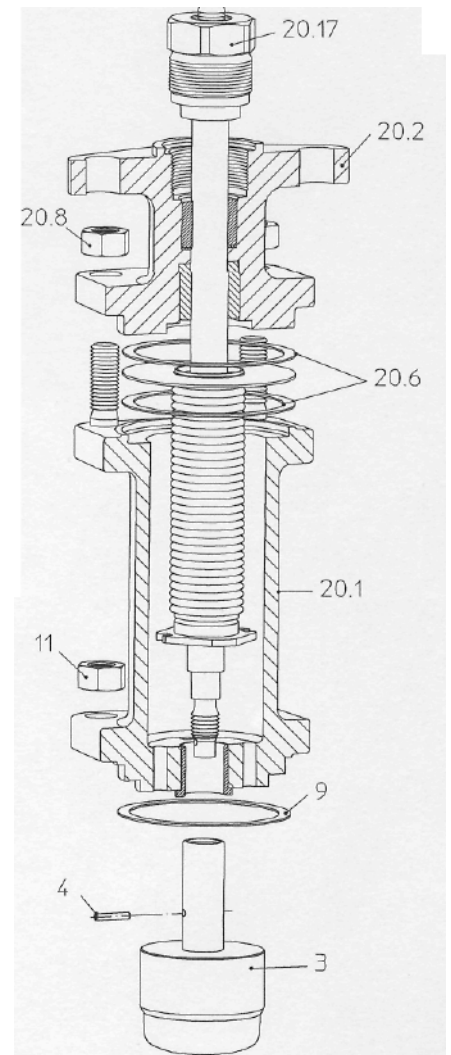

26.1.4 Replacing the Plug, Spindle and Seating

- Remove the actuator (see operating instructions for actuator)

a) Control valves

- Detach the mounting bonnet (7).
- Slacken screw joint (19) by about one turn.
- Extract and replace the plug with spindle.
- Replace the gasket (9).
- Set the mounting bonnet cover in place and secure it with nuts (11) tightened crosswise.

Plug and spindle can only be replaced completely.

b) Control Valves with Bellow Seal

- Unscrew the nuts (11).
- Remove the bellows housing (20.1) with plug (3).
- Keep the spindle pressed down.
- Remove the clamping sleeve (4).
- Unscrew the plug (3).
- Fit the new plug in the reverse order.
- Drill the plug and insert new pin.

The spindle can only be replaced complete with bellows

c) Replacing the Seating Ring (only Fig. 55.445 and Fig. 55.446)

The seating ring is screwed into the valve body and can be unscrewed for replacement or remachining. A special wrench is needed to remove the seating. It can be obtained from the manufacturer.

When fitting a new or reconditioned seating, clean thread and sealing taper in body and apply suitable lubricant.

See below for scat ring tightening torque's.

DN 15/20	100 Nm
DN 25/32	150 Nm
DN 40/50	350 Nm
DN65	480 Nm
DN80	660 Nm
DN100	980 Nm

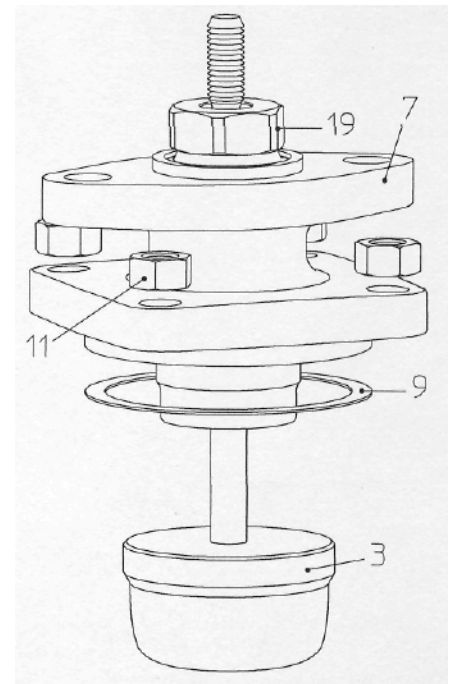

d) Pressure-balanced Plug

Replacing the Seals

- Detach valve top part and remove plug (replace if necessary).
- Prise worn piston seal (32) out of groove in plug with suitable tool (e.g. screwdriver).
- Insert new piston seal, taking care that it is in the correct position
- Replace guide ring (31).
- Clean sliding surface of guide bush (30); smooth with fine abrasive if necessary.
- Before assembly, remember that two seals (9) must be replaced.
- Set valve top part in place.
- Tighten the hexagon nuts of the cover gradually crosswise.

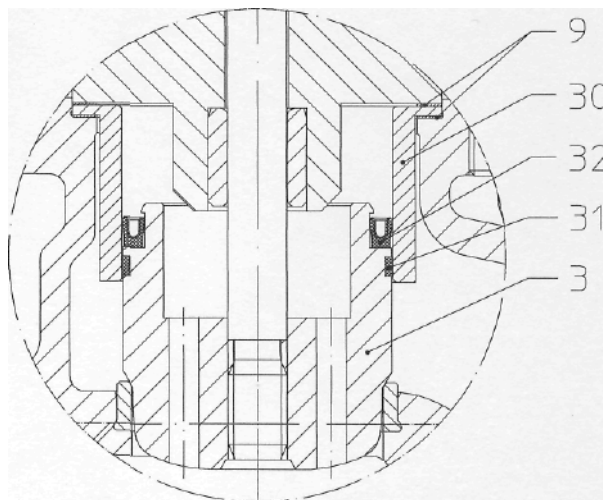

Tightening torque for hexagon nuts:

Bolts	Torque
M10	20 Nm
M12	35 Nm
M16	80 Nm

26.2 Troubleshooting

Fault	Possible cause	Corrective measures
No flow	Valve closed.	Open valve (using actuator).
	Flange covers not removed.	Remove flange covers.
Little flow	Valve not sufficiently open.	Open valve (using actuator).
	Dirt sieve clogged.	Clean / replace sieve. Relieve pressure first!
	Piping system clogged.	Check piping system.
	Kvs value of valve unsuitable.	Fit valve with higher Kvs value.
Valve spindle moves in jerks.	Stuffing box sealing too tight (for valves with graphite packings).	Slacken screw joint (25/20.17) slightly. Valve must not start leaking!
	Valve plug slightly seized owing to solid dirt particles.	Clean internals, smooth rough spots.
Valve spindle or plug cannot be moved.	Seating and plug clogged with dirt; especially with V-port and perforated plugs.	Clean seating and plug with suitable solvent.
	Valve plug seized in seating or guide owing to deposits or dirt in medium.	Replace plug and seating; use parts made from different material if necessary.
Valve spindle leaking.	PTFE V-ring unit damaged or worn.	Replace ring pack
	In valves with packed stuffing boxes, tighten sleeve nut (25).	Tighten screw joint (25); replace packing if necessary.
	Bellows defective in valves with bellow seal.	Replace bellows unit.
Leakage too high when valve is closed.	Sealing surfaces of plug eroded or worn.	Replace plug
	Sealing edge of seating damaged or worn.	Replace seating (see point 8.5), (only Fig. ...445/446)
	Piston sealing ring worn (pressure-balanced valves).	Replace sealing ring.
	Seating and/or plug dirty.	Clean internals of valve.
	Pneumatic actuator not completely vented; spring force not fully effective.	Vent actuator air chamber completely.
	Actuator not powerful enough.	Install more powerful actuator. Check service data.

27 THRUST ACTUATOR, TYPE PREMIO



Before starting up a new system or restarting a system after repairs or conversion, check:

- **Correct completion of all installation/assembly work!**
- **Circuits of the system in accordance with DIN VDE regulations and regulations of the relevant power supply company as well as compliance with all safety regulations, especially TRB 700.**
- **Hood of thrust actuator assembled.**
- **Start up only by qualified personnel**

While in operation, the thrust actuator has moving and rotating parts as well as being integrated in an electrical network system. Improper handling or failure to observe the operating instructions or the valid regulations may lead to death, grievous bodily injury or substantial property damage!

When dismantling the thrust actuator the following points are to be observed:

- **Dismantlement of the thrust actuator from the fitting must only to be carried out by suitably qualified personnel.**
- **Regard TRB 700.**
- **The supply line for connecting up the thrust actuator must be in the dead state i.e. disconnected while dismantlement work is being carried out. After being disconnected, the mains power must be prevented from being switched back on again accidentally.**
- **The system must be run down (depressurised state) as the valve cone is not held without the thrust actuator and would thus be conducted by the system pressure.**

The thrust actuators are employed to actuate control or shut-off valves requiring a nominal linear stroke distance of up to 80 mm and thrust from 2.2 kN to 15 kN. The thrust actuators are set to the thrust forces specified in the technical data.

The thrust actuator, fitted with a yoke or columns, is mounted to the valve. Transfer of force is effected via a coupling safeguarded against torsion. The torsion safeguarding feature also serves as a lift indicator. The lift settings can be read off on a lift dial attached to the yoke or between the 2-ear clamps mounted to the column.

The electrical components are accommodated separately from the gearbox underneath a sealed hood, thus being protected against operating and environmental effects. Following removal of the hood, easy access is provided to the switch gear and indicating feature. The rotary motion of the motor is transmitted to the spindle nut by means of spur gear. The drive spindle, which is safeguarded against torsion, screws its way into the spindle nut and thus performs a pull or push motion

depending on the sense of rotation. In the final positions of the valve, the spindle nut is pressed against a set of springs so as to produce closing force.

The motor is switched off by means of two load-dependent switches and one stroke-dependent switch. The load-dependent switches will also switch off the motor if foreign bodies have lodged themselves between the valve seat and cone. The load-dependent switches serve to protect the valve and thrust actuator against damage.

27.1 Manual operation

27.1.1 2.2 - 5 Kn



The handwheel always rotates during motor-driven operation (running indicator). Never activate manual operation while the motor is running. Injury hazard!

In the manual operating mode pay careful attention in the final positions that the handwheel is only turned to the point where the torque switch trips (audible click) as otherwise damage will be caused to the thrust actuator! Since the handwheel always follows during motor-driven operation (running indication), never operate by hand while the motor is running -potential injury hazards!

With the motor in the stationary state, the thrust actuator can be run in the open and closed state with the handwheel firmly meshed with the gear.

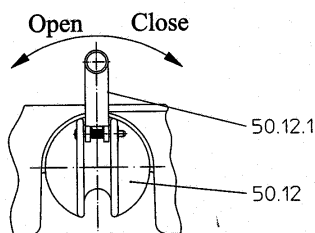

Proceed as follows:

- Swing out lever (50.12.1) from handwheel (50.12).
- Turning in clockwise direction--> closes valve.
- Turning in counter-clockwise direction--> opens valve

27.1.2 12 - 15 Kn



Do not attempt to engage manual operation until the motor has stopped. Switching over while the motor is running may damage the thrust actuator.

In the manual operating mode pay careful attention in the final positions that the handwheel is only turned to the point where the torque switch trips (audible .click) as otherwise damage will be caused to the thrust actuator!

With the motor in the stationary state, the thrust actuator can be run in the open and closed state with the engageable handwheel.

Proceed as follows:

- Fold the turning handle out of the handwheel (A)
- Turn the handwheel slightly and push in the engaging button for manual mode (8)
→ the button engages
- Turning in clockwise direction → closes valve
- Turning in counter-clockwise direction → opens valve

The motor is no longer in mesh when the handwheel is engaged. The handwheel is automatically disengaged when the motor starts and the motor is once more in mesh.

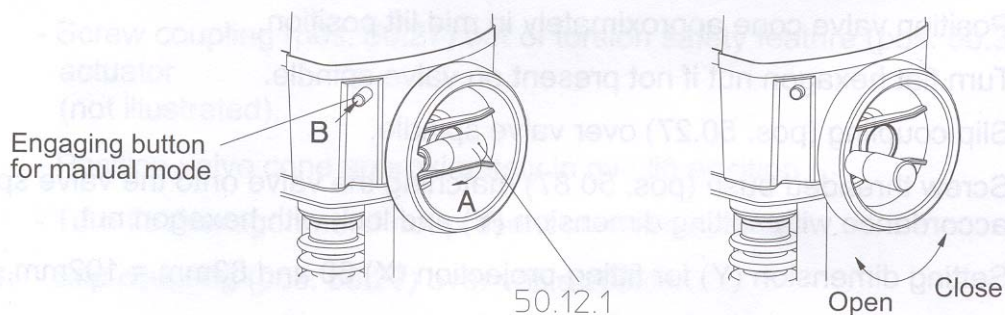

27.2 Settings



The thrust actuator may only be operated for a short time without the hood for unavoidable setting operations to the potentiometers, travel switches and the electrical options. While these operations are in progress, the thrust actuator has hazardous, live, uninsulated parts exposed as well as moving and rotating parts.

Improper execution of the setting operations or lack of care may cause death, grievous bodily injury or substantial property damage.

Operation of the thrust actuator without the hood for any purpose other than that described above is strictly prohibited.

27.2.1 Torque and travel switches -standard feature

As standard, thrust actuators are equipped with a load-dependent travel switch for the closing direction (S1), a load-dependent travel switch for the opening direction (S2) and a stroke-dependent travel switch for the opening direction (S3). The load-dependent travel switches (S1, S2) switch off the motor as soon as the factory-set thrust force is attained.



The settings of load-dependent travel switches must on no account whatsoever be changed!

The stroke-dependent travel switch (S3) switches off the motor as soon as the lift or stroke is attained. If the thrust actuator is supplied on a straight through valve, the stroke-dependent travel switch S3 is set in such a way that the motor of the thrust actuator is switched off as soon as the maximum valve-lift is attained.

If the thrust actuator is supplied on a three-way valve, the trip cam belonging to travel switch S3 is set in the opening direction in the trip slide to such a downward extent that the upper final position of the valve is attained prior to travel switch S3 being reached, thus causing the load-dependent travel switch S2 to switch off the motor.

For this function, all three switches reveal interlock-controlled circuitry on the board. If the standard travel switches are to be integrated directly into the facility control system, the standard board can be replaced by optional boards PA or NA (only 2.2- 5 kN).

27.2.2 Connection boards PA or NA (only 2.2- 5 kN)

On connection boards PA or NA, the standard travel switches S11/S21, S12/S22 and S13/S23 do not reveal interlock-controlled circuitry and can be integrated individually into the facility control system.

The 3 contacts on each of the switches S11/S21, S12/S22 and S13/S23, designed as double-throw contacts, are -in the case of these boards - brought out on terminals 40-48 and can be freely connected.

The switches on the PA optional board (standard-voltage connection board) are designed for switching capacities of up to 10A, 250V AC. The switches on the NA optional board (low-voltage connection board) are designed for switching capacities of up to 0.1 A, 4-30V (gold contacts).

27.2.3 Potentiometers

The potentiometers are used for electrical position acknowledgement on the facility control system or for the options -electronic position controller ES11 or electronic position indicator RI21

If the thrust actuator is supplied with the valve and built-in potentiometer, the potentiometer is assembled and set ready for operation.

27.3 Putting the actuator into operation



Actuator components which rotate or move during operation are coloured red. Crushing or injury hazard!

Make sure that -all works has been completed and hood of thrust actuator assembled.

When placing into service proceed as follows:

- Using the handwheel, run the thrust actuator to approximately mid lift position.
- Apply brief pulses to the thrust actuator for each direction of movement and check whether the directions of movement correspond to those desired. If this is not the case, the pulse lines governing the opening and closing action must be exchanged on the thrust actuator.

- Run thrust actuator to the final position in each direction of movement and check whether it switches off automatically and whether all externally moving parts are able to move freely.
- If failing to function properly, check all installation and setting work previously carried out, correcting if necessary, and afterwards place into service once again.

27.4 Diagram

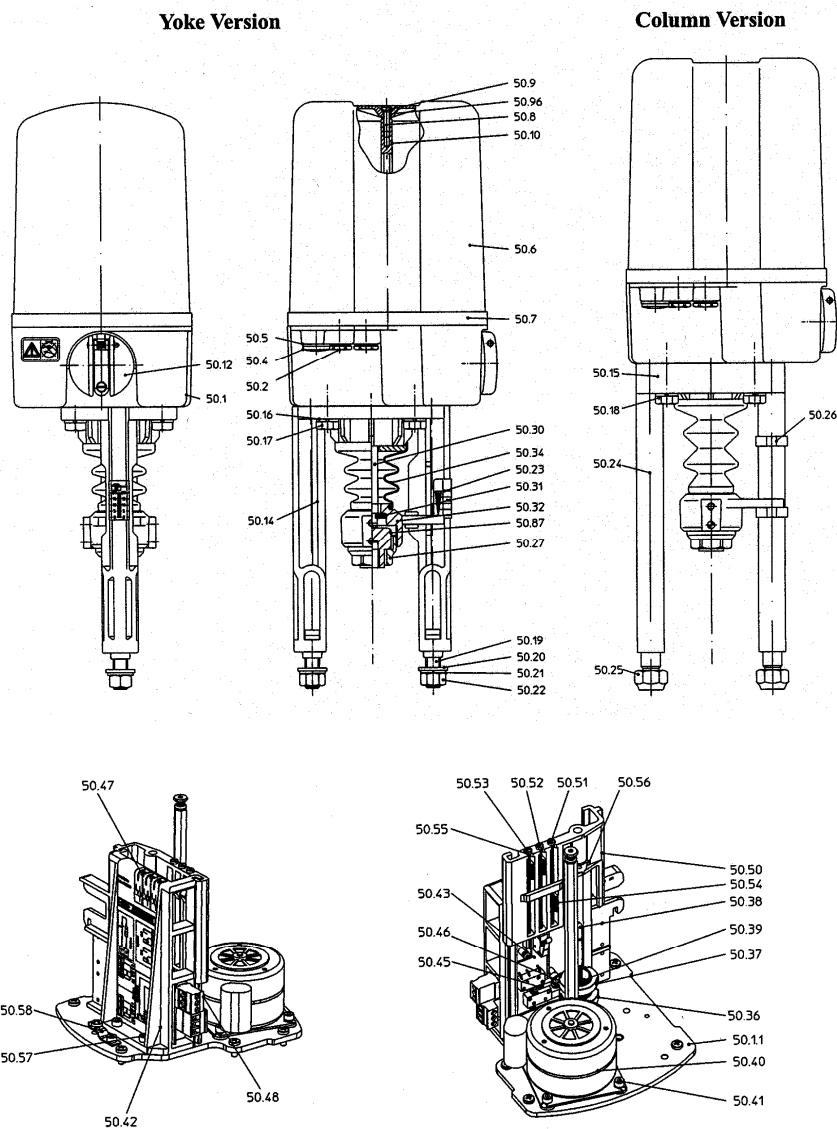

27.5 Maintenance

The thrust actuator requires very little maintenance. Accordingly maintenance in specified intervals is not necessary. Depending on the conditions governing use, the maintenance and maintenance-intervals have to be defined by the operator (see TRB 700).

The thrust actuator must not be cleaned with high-pressure equipment or aggressive solvents or detergents injurious to health or highly inflammable. During and after cleaning, an inspection should be carried out of the sealing points on the thrust actuator. If there is any sign of lubricant escaping or dirt having accumulated, the sealing elements must be repaired.

27.6 Dismantlement of thrust actuator



The supply line for connecting up the thrust actuator must be in the dead state i.e. disconnected while dismantlement work is being carried out. After being disconnected, the mains power must be prevented from being switched back on again accidentally.

The system must be run down (depressurised state) as the valve cone is not held without the thrust actuator and would thus be conducted by the system pressure.

Valve plug approximately in mid lift position -on no account supported inside a seat!

To dismantle the thrust actuator proceed as follows:

- Loosen counter-sunk screw in hood, carefully remove hood.
- Disconnect all cables led into thrust actuator from outside and remove from thrust actuator.
- Place hood on carefully from above and fix in place with counter-sunk screw and rubber gasket.
- Loosen grub screw inside torsion safety feature; screw coupling out of torsion safety feature .
- Loosen clamping bolts connecting the thrust actuator to the fitting.
- Remove thrust actuator from valve.

27.7 Troubleshooting

In the event of malfunctions or disturbances in operation, compare the data referring to operating voltage, actuating signal and temperature to the data specified on the layout drawing of the control system. Also check whether the given operating conditions correspond to those specified in the data sheet or to the technical data specified on the type identification plate.

All relevant safety regulations must be observed when carrying out the troubleshooting procedure, especially TRB 700.

Contact the supplier/manufacturer if faults cannot be rectified on the basis of the following "troubleshooting table".

27.7.1 Troubleshooting table

Fault	Possible Causes	Remedy
Thrust actuator fails to move	Power failure	Ascertain and eliminate cause
	Fuse has blown	Replace fuse
	Thrust actuator not properly connected	Rectify connection on thrust actuator in accordance with circuit diagram
	Short circuit due to: -moisture -wrong connection -motor has burned out	Ascertain exact cause, -Dry the thrust actuator and eliminate leakage -Rectify connection on thrust actuator in accordance with circuit diagram -Check whether the mains voltage agrees with the voltage specified on the rating plate. Have motor changed.
	Connector contacts not plugged in/not properly plugged into jack strip	Insert connector firmly in jack strip thus affected
	(Only for 12- 15 kN) Handwheel is still engaged and does not disengage when the motor starts up	Unscrew the motor mounting screw closest to the cable feed through. (Manual release of the handwheel disengagement mechanism.)
Thrust actuator alternates between clockwise and counter-clockwise rotation	Motor operating capacitor defective	Have motor operating capacitor replaced
Thrust actuator fails to run to final positions and also produces chatter	Load-dependent limit switches out of adjustment / defective	Remove thrust actuator and send to factory for repair
	Voltage drop due to excessively long connecting cables or inadequate conductor cross-section	Lay connecting cables in accordance with requisite output
	Mains fluctuations beyond permissible tolerance limits	Arrange for "clean" mains system within requisite tolerances
	System pressure too high	Reduce system pressure
Periodic failure on thrust actuator	Loose connection on feedline	Tighten connections on terminal strips
Thrust actuator is switched off in opening direction prior to load-dependent switch (threeway valve)	Travel switch S3 not set corresponding to use	Set travel switch S3 in accordance with operating instructions

28 AUTOMATIC VENT VALVE, G8070, F8071

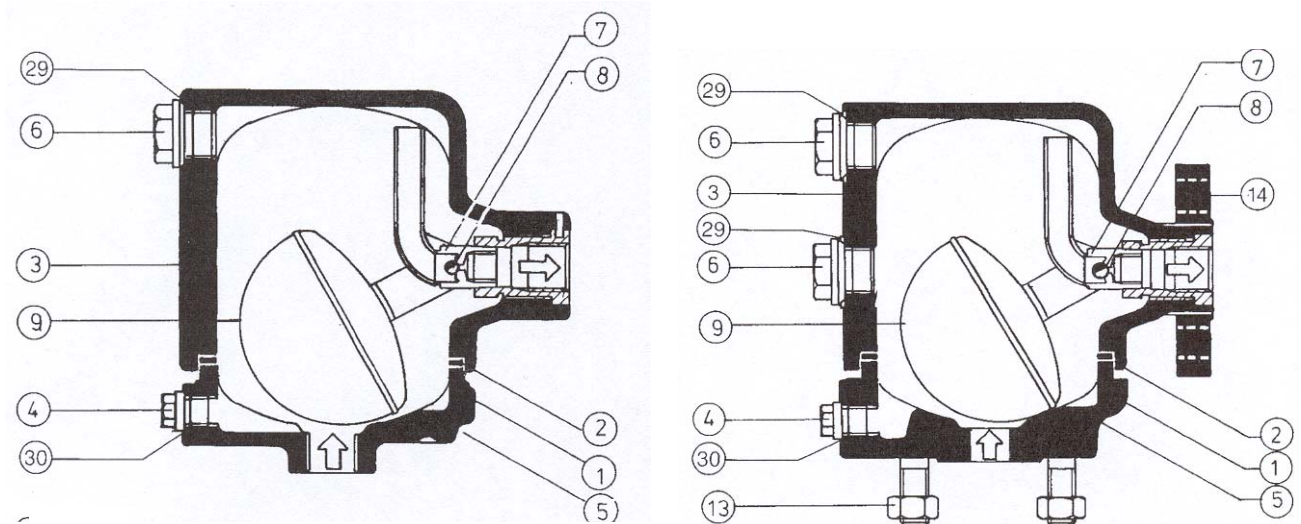

Type G

Type F

- 1 Housing cover: GG-25 or GGG-40.3
 - 2 Housing seal: soft material (asbestosfree)
 - 3 Lower part of housing: GG-251 GGG-40.3
complete with mount for control: SS 1.4104 and soft iron seal* (SS 1.4571) °
 - 4 Control screw: SS 1.4104
 - 5 Set of stud DIN 939 with nuts: DIN 934 and washer DIN 125 (not visible)
 - 6 Plug: 9S20K
 - 7 Float control complete: SS 1.4057/1.4112/1.4301/1.4541 (SS 1.4571)"
 - 8 Supporting structure with rotary-slide-valve and cotter pin*:
SS 1.4057/1.4301/1.4112/1.4541 (SS 1.4571)"
 - 9 Float with fork: SS 1.4301 (SS 1.4571)
 - 13 Set of studs: DIN 9391 with nuts DIN 934 ,
 - 14 Flange: St 37-2
 - 29 Seal: soft iron .
 - 30 Seal: soft iron
- * Individual parts cannot be delivered for reasons of tightness.

The float control assembly discharges air and gases from all liquid carrying systems without time lag, independent of pressure and temperature variations. With the float in the lower position the outlet cross-section is open. Air and gases escape through the upturned immersion tube. Rising of the liquid level lifts the float and causes to close the outlet.

29 STOP VALVES FIG 215 AND FIG-216

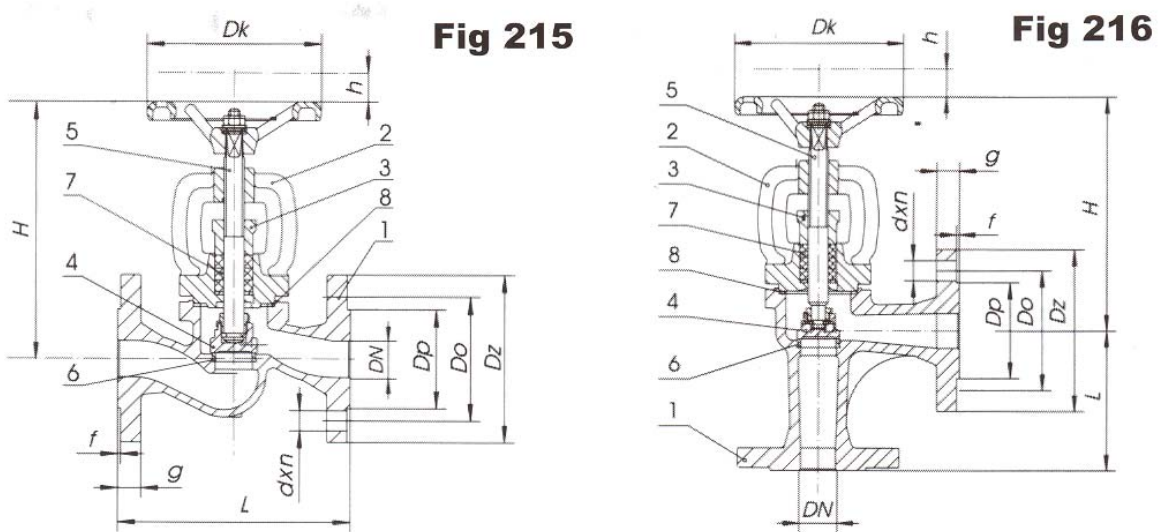

- 1 Body
- 2 Bonnet
- 3 Flange
- 4 Disc
- 5 Stem
- 6 Seat ring
- 7 Gland packing
- 8 Seal

These valves need no maintenance.

30 AUTO FILTER TYPE 6.60

30.1 General

The fully automatic back-flushing filter is used to filter a variety of fluids. The filter element assemblies are cleaned automatically by compressed air assisted back-flushing. One clean chamber is always in reserve. This self-cleaning filter consists basically of lower housing with connection flange for the removal of flushing fluid (sludge discharge), change-over system housing with filter inlet and outlet flanges, automatically vented filter chambers containing candle elements, pneumatic swivel drive with attached control valve and end position switch, air supply with non-return valve, shut-off valve and pressure regulator, safety valve, differential pressure indicator Δp_1 , flushing valve with manual initiation and electric control system in its own switch box separate from the filter.

Filtration Phase

(see Drawing Z 32330 p. 1)

The medium to be filtered flows down into the change-over system housing and passes from there through the chamber inlet and the connected filter chambers to the candle elements.

The medium flows through the filter elements from the outside to the inside and the contamination in the medium is retained on the filter mesh of the candle elements. The cleaned fluid passes to the filter outlet.

In this position the air supply (by means of the solenoid valve) keeps the sludge discharge closed and compressed air is maintained in the air receiver ready for the next backflushing cycle.

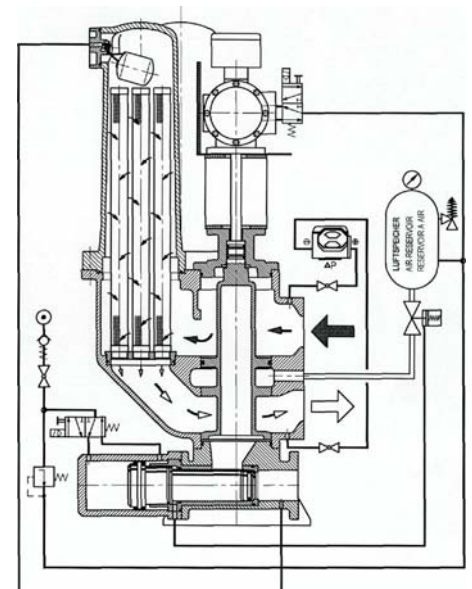

Drawing Z32330 BL 1

Back-Flushing Operation

(see Drawing Z 32330 p. 2)

The contamination retained on the candle elements produces an increasing pressure differential between the filter inlet and outlet. This difference in pressure is indicated optically on the differential pressure indicator when a set value is reached and an electrical contact initiates the back-flushing.

When the back-flushing cycle is initiated, the pneumatic swivel drive is switched by the attached control valve and the plug rotates from the chamber held in reserve to the filter chamber to be cleaned. The connection of the reserve chamber, with its clean candle elements, causes an immediate reduction in the pressure differential. When the

stop plug reaches the filter chamber to be cleaned the turning motion of the pneumatic swivel drive is stopped by means of the attached end position switch.

The solenoid valve (mounted on the sludge discharge) is then switched electrically and air from the air supply passes to the rear side of the sludge discharge valve shaft. The sludge discharge valve opens and pressure is released from the chamber now shut off.

This allows the compressed air in the upper region of the plug to immediately expand and thus creates additional space for the fluid displaced (by the air) in the backflushing cycle!

While the sludge discharge valve shaft is opening, the control system air reaches the attached flushing valve (once the pressure has been released on the filter chamber). The flushing valve opens and the compressed air from the air receiver dispatches the clean fluid present and pushes it in the counter current direction through the mesh of the screw-in candle elements. The pressure drop thus generated flushes off the contamination deposited on the mesh and washes it out of the filter housing via the open sludge discharge valve.

The air flow is continued for a short period (flushing period) before the solenoid valve (on the sludge discharge) is electrically switched over, causing the sludge discharge valve to close. At the same time the flow of air from the control system to the connected flushing valve is interrupted and thus also stops the flow of the stored back-flushing air. The back-flushed filter chamber is now refilled with clean medium through the refill bore until operating pressure is achieved. Only then is the delay of the electric control cancelled for the next back-flushing operation.

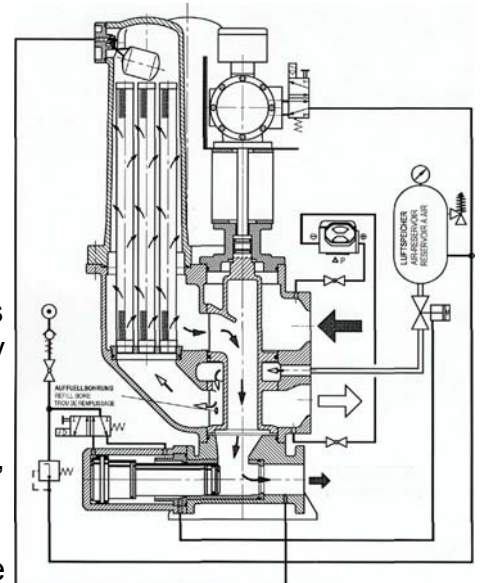

Drawing Z32330 BL 2

30.2 Start-up

The following requirements must be met for the commissioning of the filter:

1. Clean and dry compressed air for the control system at between 4 and 10 bar operating pressure must be available at the open shut-off valve.
2. Switch on the electricity using the "Main Switch" on the switch box. The "Power" lamp respectively LED-operating display lights up. (Activation of the main switch initiates a back-flushing cycle.)
3. To check the electric control system a back-flushing cycle should now be performed by activating the "Manual" trip on the switch box.
4. Open the slide valve at the filter outlet. Slowly open the slide valve at the filter inlet (avoiding pipe hammer). A further back-flushing cycle is to be performed using the "Manual" trip on the switch box. Once the back-flushing operation is completed, the "Flushing" respectively the display "SP.1" lamp goes out. If these conditions are met, the filter is in the start position and is therefore ready for operation.

After completion of a back-flushing cycle, the next backflushing operation can only be initiated (manually or by means of the differential pressure indicator) after a time delay. This time delay corresponds to the time preset on the time relay "K1A" or the preselected time "PA.5" in the electronic control. Make sure that the cleaned filter chamber is filled.

NOTE: Possible time interval calculation for time-dependent back-flushing Let the filter run for 24 hours using the differential pressure and establish the number of back-flushing operations (flushing cycle counter or display). Calculate the average flushing interval. Set the flushing interval (shortened by 30%) on the time relay or PA.2.

30.3 Control of automatic filter, type 6.60.

Selecting parameter assignment mode of A14A1 (LOGO!) controller:

Note in parameter assignment mode, the LOGO! continues execution of the circuit program.

1. Press ▼ as many times as required to get date into the display
2. Press ESC to change from RUN to parameter assignment mode.

LOGO! changes to parameter assignment mode and opens the parameter assignment menu:

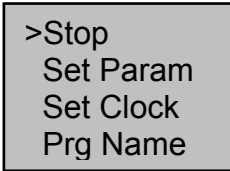

>Stop
Set Param
Set Clock
Prg Name

Moving from stop to Prg Name by pressing ▼ or ▲ buttons. Selection by pressing OK. Back by pressing ESC

Description of the four menu items of the parameter assignment menu:

1 Stop is selected to stop the circuit program.

After the program is stopped it can be started from the opening menu. From where also the clock and the summer / winter time can be set by selecting Clock..

2 Set Param is selected to change the filter parameters.

Selection by pressing ▼ (cursor moves from Stop to Set Param) and then OK.

Moving from parameter to another by pressing ▼ and ▲ buttons.

Parameters are changed by pressing OK when the parameter to be changed is in display.

Back by pressing ESC.

3 Flush counter reset (example)

```
F CTR
On= 0
Off= 0
Cnt= 21
```

Flush counter value is in parameter Cnt

Press ► (or◀) as many times as required to move the cursor on 2.
Press ▼ 2 times to change 2 to 0. Press ► once to move the cursor
on 1. Press ▼ once to change 1 to 0. Press OK.

4 Sludge pump run time change (sludge pump is an option which may not be installed).

```
SP RUN T
TH =02:00m
TL =00:00s
Ta =00:00
```

Sludge pump run time value is in parameter TH. 02 means minutes, 00
means seconds.

Press ► (or◀) as many times as required to move the cursor on 02:00.
Press ▼ or ▲ on numbers to change the run time. When the run time is
changed press OK.

30.3.1 Chamber fill up time change.

FILL UP
T =03:00m

Ta =03:00m

Chamber fill up time is in parameter T 02 means minutes, 00 means seconds.

Press ► (or◀) as many times as required to move the cursor on 03:00.
Press ▼ or ▲ on numbers to change the fill up time. When the fill up time is changed press OK.

30.3.2 Flush period change

F PERIOD
T =02:00h

Ta =00:00h

Flush period time value is in parameter T. 02 means hours, 00 means minutes.

Press ► (or◀) as many times as required to move the cursor on 02:00.
Press ▼ or ▲ on numbers to change the flush period time. When the flush period is changed press OK.

30.3.3 Flush time change

```
F TIME
TH =05:00s
TL =05:00s
Ta =00:00
```

Flush time value is in parameter TH. 05 means seconds, 00 means fractional parts of seconds

Press ► (or◀) as many times as required to move the cursor on 05:00. Press ▼ or ▲ on numbers to change the flush time. When the flush time is changed press OK.

30.3.4 Parameter settings

Parameter	Factory setting	Setting limits which are not to go under or exceed
Sludge pump run time	2 minutes	from 2,0 to 5,0 minutes
Chamber fill up time	2 minutes	from 2,0 to 5,0 minutes
Flush period	2 hours	from 0,5 to 5 hours
Flush time	5 seconds	from 5,0 to 10,0 seconds

30.3.5 Set clock is selected to set time and date.

```
Set Clock
Su 00:00
YYYY-MM-DD
2003-01-01
```

Press ► (or◀) as many times as required to move the cursor on parameter to be changed. Press ▼ or ▲ to change the parameter (e.g. day). After all parameters are correct press OK.

Prg Name is not used.

30.4 Maintenance

Even automatic filters require inspection and servicing at regular intervals. It is to be noted in particular that despite regular back-flushing the filter mesh can become clogged in the course of time, depending on the quality of the medium and the bypass cleaning available.

Contamination on the mesh can be removed by cleaning the candle element manually using an appropriate solvent. An increase in the clogging on the mesh can be inferred from the progressively shorter intervals between back-flushing cycles. The number of back-flushing cycles can be seen on the "Flushing Cycle Counter" respectively display on the switch box.

To maintain trouble-free operation, the following points are to be noted:

- a) All connections are to be regularly checked for leaks.
- b) Candle elements are to be dismantled and inspected initially after 500 flushing cycles, then after 5 000 and later every 10 000 flushing cycles. If, however, a sharp reduction in the intervals between back-flushing cycles should occur, inspection and cleaning should be carried out sooner. If sudden lengthening of the intervals between back-flushing cycles should occur, all candle elements must be inspected without fail for damage.



Before the cartridge elements are dismantled, the automatic filter must be completely drained by automatic back-flushing (i.e. all filter chambers). "Manual" activation on the control box. Care must be taken to ensure that the liquid level is below the cartridge element before the element is dismantled.

The candles are subjected to wear through reciprocal loading. It is therefore recommended, that a complete candle filter element, the number of candle elements depending on the size of the filter, to be kept in stock.

It is expedient to renew all seals when overhauling the filter.

Check the sludge discharge for leaks every 10 000 flushing cycles. No medium should run from the end of the sludge discharge line during the filtration phase (except during the flushing cycle).

You must close the compressed air supply valve (item 127), then starting a manual back-flushing, before you are allowed to remove the manometer (item 72). This will ensure that the compressed air reservoir (item 13) is pressure released.

30.4.1 Servicing tools

The following special tools are supplied for servicing the filter:

Special key with SW 10 or 14 for dismantling the filter chamber.



Special key for unscrewing the candle elements from the candleholder.

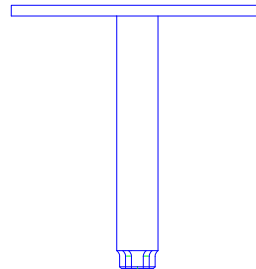

Key for opening the switch box and hand crank for operation during a power failure.

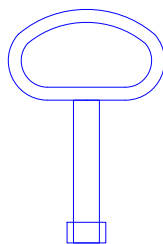

30.4.2 Candle element cleaning agent "BOLL CLEAN 2000"

The choice of cleaning medium depends on the type of the contamination. With fuels precipitation of paraffin and asphalt or with lubricating oils mixing of different types of oil can form solid encrustations on the mesh. Effective cleaning of fine meshes is achieved by soaking in "BOLL CLEAN 2000" followed by blasting with compressed air using a cleaning gun.

Product description

BOLL CLEAN 2000 is a fluid cleaning and degreasing agent with a wide range of application. It can be used for practically all cleaning and degreasing purposes. BOLL CLEAN 2000 cleans rapidly, thoroughly and extremely economically.

Use of BOLL CLEAN 2000 renders safety precautions superfluous. BOLL CLEAN 2000 has these outstanding characteristics without exhibiting the disadvantages of solvent cleaners.

- BOLL CLEAN 2000 is non-flammable
- does not require special marking
- does not have an irritating odour
- is not caustic
- is physiologically unobjectionable
- is biologically degradable
- is registered with the Federal Office for the Environment,
Reg.-No. 04860019

BOLL CLEAN 2000 can be undercooled or overheated during storage, but remains fully usable when returned to normal temperature.

Mesh contaminated with heavy oil:

Elements contaminated with heavy oil must be soaked in a standard commercial solvent. After soaking, the elements are cleaned in the BOLL & KIRCH Type 5.04 Cleaning Device using BOLL CLEAN 2000 and high-pressure pump.

Instructions for use

Use of BOLL CLEAN 2000 is not restricted to a particular method of cleaning. Depending on the operating conditions, BOLL CLEAN 2000 can be used in a dip bath, in a spraying plant, in steam jetting or in manual application using a cloth, brush or sponge. It can be used warm or cold. BOLL CLEAN 2000 is miscible with water - even seawater. Concentration for mesh cleaning: 1:2,5. Temperature: up to a maximum of 60°C. The concentration depends on the type and thickness of the adhesive substance to be removed. When used in concentration below

1:30 rinsing is usually not required. No visible film remains on the surface.

30.5 Manual cleaning of the candle filter elements



Before the cartridge elements are dismantled, the automatic filter must be completely drained by automatic back-flushing (i.e. all filter chambers). "Manual" activation on the control box. Care must be taken to ensure that the liquid level is below the cartridge element before the element is dismantled.

Remove the whole filter element assembly. Then soak the filter element assembly, with the opening of the candle elements facing down, in a suitable tank filled with solvent. Detached contaminants can then sink downwards out of the candle.

The soaking time and the relevant solvents are:

- a) In cold BOLL CLEAN 2000 cleaner the maximum soaking time is 24 hours
- b) In Filterclean (Vecom) the maximum soaking time is 12 hours
- c) In Reiniger B85 (Vecom) the maximum soaking time is 12 hours
- d) In gas oil the maximum soaking time is 48 hours

After soaking, remove the whole filter element assembly from the tank and place it on a suitable stand (e.g. perforated sheet metal) with the candle element opening pointing down and allow the solvent to drain.

Now with the cleaning gun supplied blow compressed air through the candles from the inside to the outside.

After this procedure, the complete filter element assembly should be immersed in fresh cleaner, with the candle element opening downwards, and rinsed through with an up and down motion.



The washing procedure described above should only be carried out in a separate tank using clean solvent. The solvent can then be used again for the next soaking procedure.

Allow the element assembly to drain again and dry it by blowing compressed air through it again from the outside to the inside. The manual cleaning procedure described here has produced adequate results (ca. 60% clean) in similar applications.

Almost 100% cleaning is only possible manually, in our experience, by using the Type 5.04 High Pressure Cleaning Unit with BOLL CLEAN 2000.

30.6 Maintenance instructions (by-pass filter)



Take the by-pass filter out of operation before carrying out maintenance work on it!

To remove the screen insert, proceed as follows:

- 1 Slacken venting screw (item 332) of the cover retaining arrangement, and in this way check that the filter housing is not pressurised.
- 2 Unscrew the venting screw until the cover panel (item 335) over the concealed cover screws (item 323) can be swivelled.
- 3 Remove cover (item 306) after slackening the cover screws and pull screen insert out of the filter housing.
- 4 Clean screen insert with suitable solvents (see KV349) and then blow through with compressed air from the inside to the outside.
- 5 Check seals and replace any damaged seals.
- 6 Assemble filter in the reverse order.

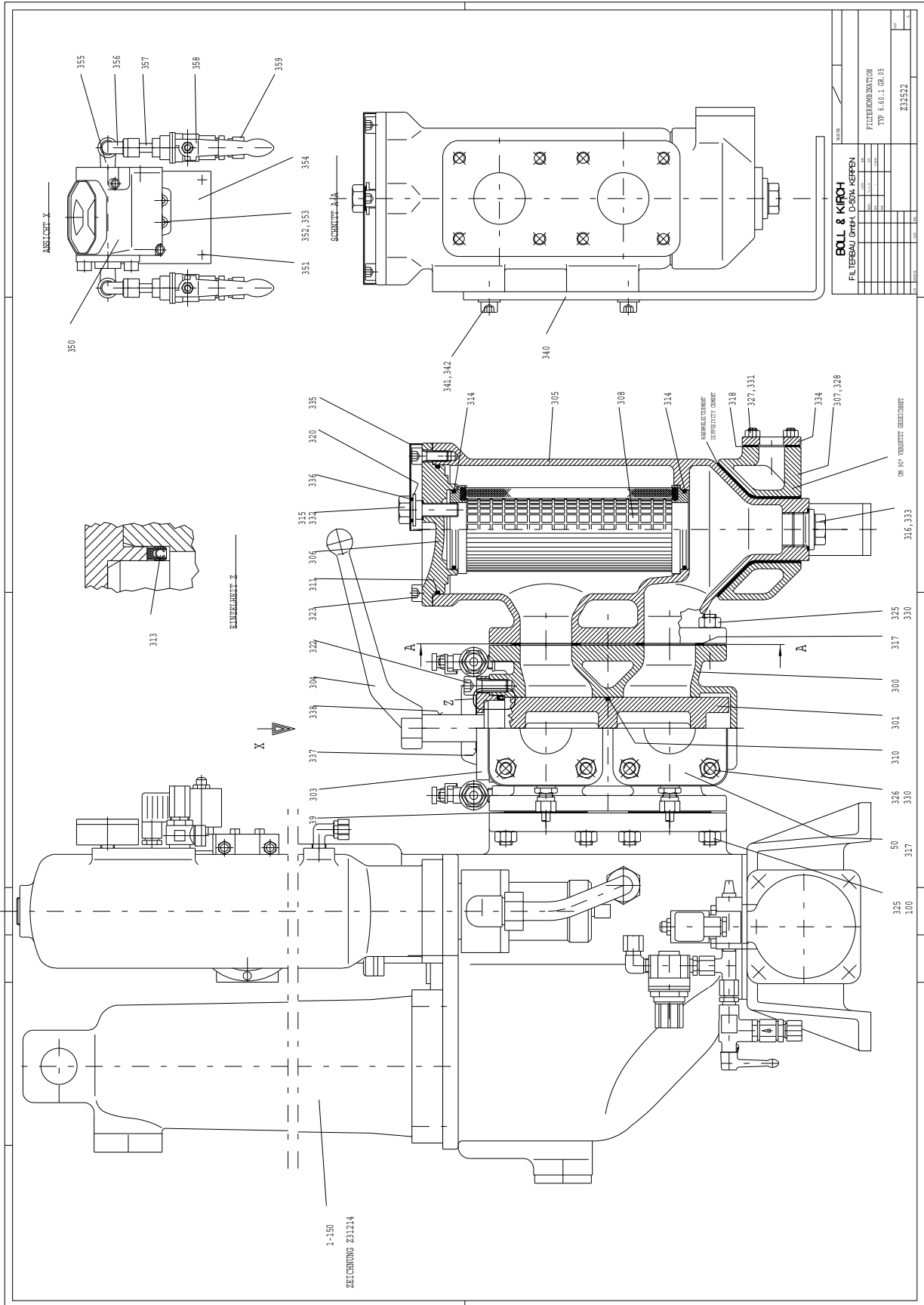

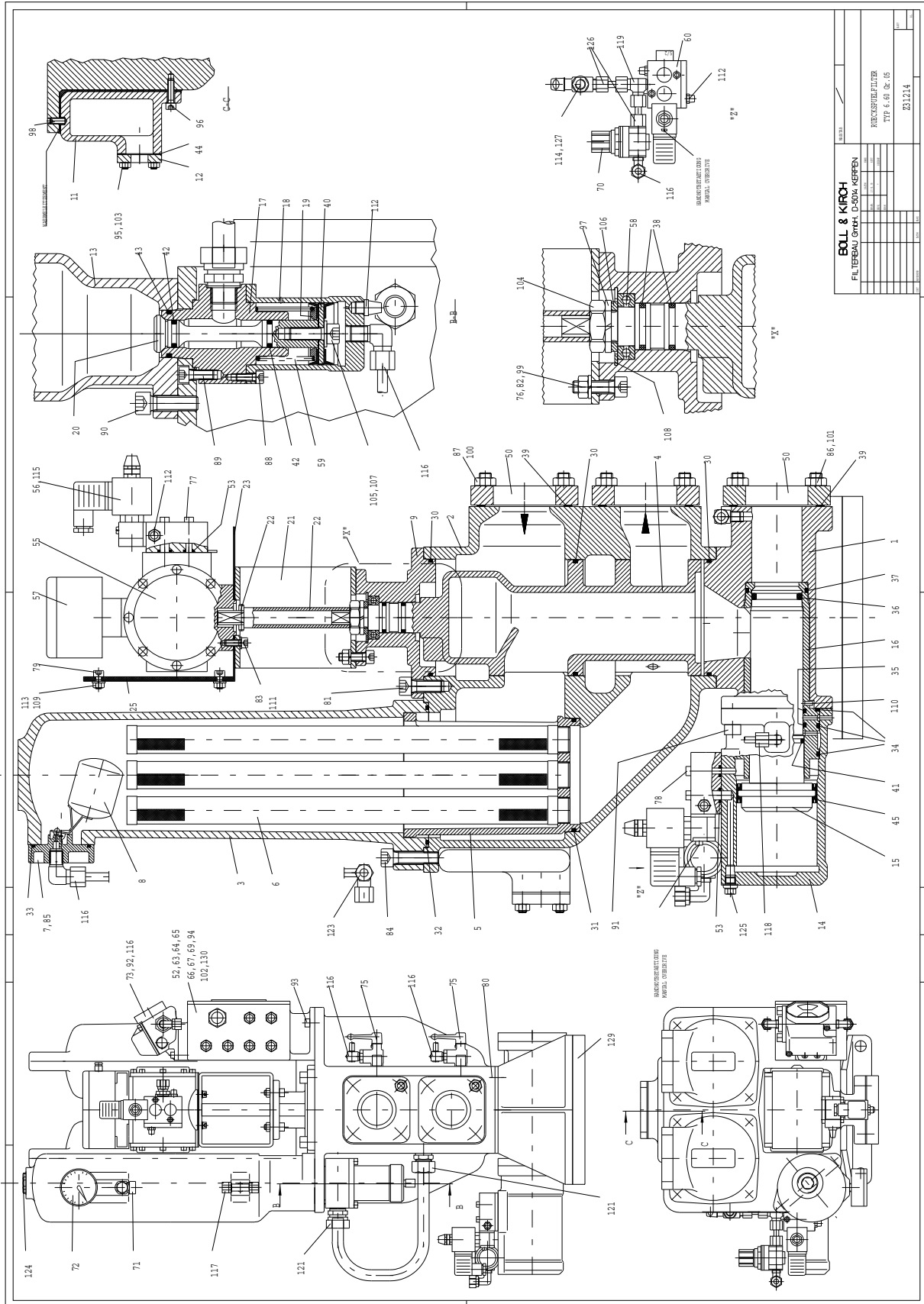

BOLL & KIRCH	
FILTRIERHAUPTGERÄTE	
BRUNNENFILTER	
Typ 6.60 Gr.05	
231214	
1	1
2	1
3	1
4	1
5	1
6	1
7	1
8	1
9	1
10	1
11	1
12	1
13	1
14	1
15	1
16	1
17	1
18	1
19	1
20	1
21	1
22	1
23	1
24	1
25	1
26	1
27	1
28	1
29	1
30	1
31	1
32	1
33	1
34	1
35	1
36	1
37	1
38	1
39	1
40	1
41	1
42	1
43	1
44	1
45	1
46	1
47	1
48	1
49	1
50	1
51	1
52	1
53	1
54	1
55	1
56	1
57	1
58	1
59	1
60	1
61	1
62	1
63	1
64	1
65	1
66	1
67	1
68	1
69	1
70	1
71	1
72	1
73	1
74	1
75	1
76	1
77	1
78	1
79	1
80	1
81	1
82	1
83	1
84	1
85	1
86	1
87	1
88	1
89	1
90	1
91	1
92	1
93	1
94	1
95	1
96	1
97	1
98	1
99	1
100	1

30.7 Part lists

30.7.1 Part list for type 6.60.1

Document 069320, 3.11.2004

Item	ID no.	Description	Qty	Unit
00001	6530355	housing lower part	1	pcs .
00002	6530354	change-over housing	1	pcs .
00003	6537759	filter chamber	2	pcs .
00003	2000004	stud bolt	4	pcs .
00004	6335469	cock plug	1	pcs .
00005	5007847	candle support	2	pcs .
00006	1104422	filter candle according to order	16	pcs .
00007	5906594	cover	2	pcs .
00007	5218298	nozzle	2	pcs .
00007	6712641	bow	2	pcs .
00007	2000266	slotted cheese head screw	4	pcs .
00008	2610023	float	2	pcs .
00008	2611123	pin	2	pcs .
00008	3530032	threaded pipe fitting	2	pcs .
00009	6530356	cover switchover housing	1	pcs .
00011	6530357	heating chamber	1	pcs .
00012	5000011	counter flange	1	pcs .
00013	6533516	air reservoir	1	pcs .
00014	5229568	valve housing	1	pcs .
00015	5000486	valve ram	1	pcs .
00016	5005528	valve face	1	pcs .
00017	5005609	housing	1	pcs .
00018	5006510	valve cover	1	pcs .
00019	5007512	disc	1	pcs .
00020	5006512	valve ram	1	pcs .
00021	5700156	distance piece	1	pcs .
00022	5701532	rectangular tube	1	pcs .
00022	2300011	Spring Type Straight Pin	1	pcs .
00022	5701533	square bar steel	1	pcs .
00023	5700158	mounting sheet	1	pcs .
00025	4101224	isolation plate	1	pcs .
00030	3030066	o-ring	3	pcs .
00031	3030661	o-ring	2	pcs .
00032	3030761	o-ring	2	pcs .
00033	3132369	o-ring	2	pcs .
00034	3038188	o-ring	3	pcs .
00035	3096894	o-ring	2	pcs .
00036	3096995	o-ring	1	pcs .
00037	3030063	o-ring	1	pcs .
00038	3094563	o-ring	2	pcs .
00039	3380001	high pressure gasket	3	pcs .
00040	2785451	seal piston	1	pcs .
00041	3038126	o-ring	1	pcs .
00042	3098361	o-ring	2	pcs .
00043	3038361	o-ring	1	pcs .
00044	3380049	high pressure gasket	1	pcs .
00045	3437135	double grooved ring	1	pcs .
00050	2800062	square counter flange	3	pcs .
00052	3380199	flat gasket	1	pcs .
00053	3040224	o-ring	4	pcs .

00055	4500016	double piston slewing gear	1	pcs .
00056	2656655	5/2 way valve	1	pcs.
00056	4206553	coil	1	pcs .
00056	4105912	appliance plug	1	pcs .
00056	2614072	sound absorber	1	pcs .
00057	4200143	limit switch	1	pcs.
00058	2708947	deep groove ball bearing	1	pcs .
00059	2307427	pressure spring	1	pcs .
00060	2656655	5/2 way valve	1	pcs.
00060	4206553	coil	1	pcs .
00060	4105912	appliance plug	1	pcs .
00060	2614072	sound absorber	1	pcs .
00063	5950196	connection box	1	pcs .
00064	8450198	cover for connection box	1	pcs .
00065	4105616	clamp	12	pcs .
00065	4105617	clamp	5	pcs.
00065	4100015	distance plate	3	pcs .
00066	2000258	slotted cheese head screw	2	pcs .
00067	4105805	mounting rail	1	pcs.
00069	4160350	cable gland	8	pcs .
00069	4160349	reducing ring	8	pcs .
00069	4100104	cable gland	1	pcs.
00069	4870017	plug	1	pcs .
00070	2650017	high pressure control device	1	pcs .
00071	2660005	safety valve	1	pcs.
00072	2602689	pressure gauge	1	pcs .
00073	9902572	differential pressure indicator ace. t	1	pcs .
00075	2560063	angle ball valve	2	pcs .
00076	2200235	spring ring	4	pcs .
00077	2002155	hexagon socket head cap screw	2	pcs.
00078	2002155	hexagon socket head cap screw	2	pcs .
00079	2000121	hexagon socket head cap screw	2	pcs .
00080	2000482	stud bolt	4	pcs .
00080	2100011	hexagon nut	4	pcs .
00081	2000155	hexagon socket head cap screw	4	pcs .
00082	2000132	hexagon socket head cap screw	4	pcs .
00083	2000122	hexagon socket head cap screw	4	pcs.
00084	2000158	hexagon socket head cap screw	8	pcs .
00085	2100006	hexagon nut	4	pcs .
00086	2009095	stud bolt	4	pcs .
00087	2009095	stud bolt	8	pcs .
00088	2000122	hexagon socket head cap screw	4	pcs .
00089	2000131	hexagon socket head cap screw	3	pcs .
00090	2000157	hexagon socket head cap screw	2	pcs .
00091	2000144	hexagon socket head cap screw	4	pcs .
00092	2000122	hexagon socket head cap screw	2	pcs .
00093	2000131	hexagon socket head cap screw	2	pcs .
00094	2000261	slotted cheese head screw	2	pcs .
00095	2000001	stud bolt	4	pcs .
00096	2000132	hexagon socket head cap screw	1	pcs .
00097	2209969	spring ring	1	pcs .
00098	2004354	stud bolt	1	pcs .
00099	2100047	hexagon nut	4	pcs .
00100	2100006	hexagon nut	8	pcs .
00101	2100006	hexagon nut	4	pcs .
00102	2003587	threaded flange screw	4	pcs .
00103	2100004	hexagon nut	4	pcs .
00104	2110593	hexagon nut	1	pcs .
00105	2004715	hexagon screw	1	pcs .
00106	5006107	disc	1	pcs .

00107	2200007	disc	1	pcs .
00108	2203399	locking ring	1	pcs .
00109	2200005	disc	2	pcs.
00110	2001578	headless screw	1	pcs.
00111	2209799	spring ring	4	pcs .
00112	2614171	sound absorber	5	pcs.
00113	2100003	hexagon nut	2	pcs.
00114	2608775	non return valve	1	pcs .
00115	2500024	screwing	1	pcs .
00116	2500025	screwing	2	pcs .
00116	2500025	screwing	6	pcs .
00117	2505496	screwing	1	pcs.
00118	2500029	screwing	2	pcs
00119	2507461	screwing	1	pcs.
00121	2508115	screwing	2	pcs.
00123	2507808	screwing	1	pcs .
00124	2001772	screwed sealing plug	1	pcs.
00124	3275525	gasket	1	pcs .
00125	2000186	screwed sealing plug	1	pcs .
00125	3270001	gasket	1	pcs .
00126	2500083	screwed socket	2	pcs .
00127	2560356	angle ball valve	1	pcs .
00128	0602645	tubing set	1	pcs .
00130	9401690	type plate	1	pcs.
00131	9407569	label : "in / out"	1	pcs.
00131	9400997	label: "on / off"	1	pcs .
00131	9407396	label : "mud drain"	1	pcs.
00131	9402898	label	1	pcs.
00131	9405704	label: " ... 2 lugs ... "	1	pcs .
00131	9403614	label: "compressed air connection"	1	pcs.
00131	9404642	label: "Delta P differential pressure	1	pcs.
00140	4300000	control box according to order	1	pcs.
00150	6705030	key	1	pcs .
00150	6705032	key for unscrewing the filter element	1	pcs .
00150	5700721	guiding bolt	2	pcs.
00300	6235819	cock casing	1	pcs.
00301	6329196	cock plug	1	pcs .
00303	6406236	cover	1	pcs .
00304	8650098	key	1	pcs.
00305	6436188	housing	1	pcs.
00306	6432960	cover	1	pcs .
00307	6532077	heating chamber	1	pcs .
00308	1174632	pleated filter element	1	pcs .
00310	3031222	o-ring	1	pcs.
00311	3034299	o-ring	1	pcs.
00313	3421241	tec-ring	1	pcs .
00314	3031525	o-ring	2	pcs .
00315	3270002	gasket	1	pcs .
00316	3270006	gasket	1	pcs.
00317	3380001	high pressure gasket	4	pcs.
00318	3380049	high pressure gasket	1	pcs .
00320	2307145	quick fixing device	1	pcs .
00322	2000156	hexagon socket head cap screw	2	pcs .
00323	2000143	hexagon socket head cap screw	6	pcs .
00325	2000004	stud bolt	16	pcs.
00326	2000004	stud bolt	8	pcs .
00327	2000001	stud bolt	4	pcs .
00328	2004354	stud bolt	2	pcs .
00330	2100006	hexagon nut	16	pcs.
00331	2100004	hexagon nut	4	pcs.

00332	5204517	screw for air escape	1	pcs .
00333	2000191	screwed sealing plug	1	pcs .
00334	5000011	counter flange	1	pcs .
00335	6706685	tab washer	1	pcs
00336	3039056	o-ring	1	pcs .
00337	9401114	label: "cock position"	1	pcs.
00338	9400220	label	1	pcs.
00340	6709832	holding device	1	pcs.
00341	2000143	hexagon socket head cap screw	2	pcs .
00342	2200007	disc	2	pcs .
00350	9902572	differential pressure indicator ace. t	1	pcs .
00351	2000121	hexagon socket head cap screw	2	pcs.
00352	2000123	hexagon socket head cap screw	2	pcs .
00353	2100003	hexagon nut	2	pcs.
00354	5700108	mounting	1	pcs.
00355	2500008	angle	2	pcs .
00356	2500025	screwing	2	pcs .
00357	2500083	screwed socket	2	pcs .
00358	2560770	ball cock	2	pcs.
00359	2500024	screwing	2	pcs .

30.7.2 Part list for type 6.60

Document 0630038, 3.11.2004

Item	ID no.	Description	Qty	Unit
00001	6530355	housing lower part	1	pcs.
00002	6530354	change-over housing	1	pcs.
00003	6537759	filter chamber	2	pcs.
00003	2000004	stud bolt	4	pcs.
00004	6335469	cock plug	1	pcs.
00005	5007847	candle support	2	pcs.
00006	1104422	filter candle according to order	16	pcs.
00007	5906594	cover	2	pcs.
00007	5218298	nozzle	2	pcs.
00007	6712641	bow	2	pcs.
00007	2000266	slotted cheese head screw	4	pcs.
00008	2610023	float	2	pcs.
00008	2611123	pin	2	pcs.
00008	3530032	threaded pipe fitting	2	pcs.
00009	6530356	cover switchover housing	1	pcs.
00011	6530357	heating chamber	1	pcs.
00012	5000011	counter flange	1	pcs.
00013	6533516	air reservoir	1	pcs.
00014	5229568	valve housing	1	pcs.
00015	5000486	valve ram	1	pcs.
00016	5005528	valve face	1	pcs.
00017	5005609	housing	1	pcs.
00018	5006510	valve cover	1	pcs.
00019	5007512	disc	1	pcs.
00020	5006512	valve ram	1	pcs.
00021	5700156	distance piece	1	pcs.
00022	5701532	rectangular tube	1	pcs.
00022	2300011	Spring Type Straight Pin	1	pcs.
00022	5701533	square bar steel	1	pcs.
00023	5700158	mounting sheet	1	pcs.
00025	4101224	isolation plate	1	pcs.
00030	3030066	o-ring	3	pcs.
00031	3030661	o-ring	2	pcs.
00032	3030761	o-ring	2	pcs.
00033	3132369	o-ring	2	pcs.
00034	3038188	o-ring	3	pcs.
00035	3096894	o-ring	2	pcs.
00036	3096995	o-ring	1	pcs.
00037	3030063	o-ring	1	pcs.
00038	3094563	o-ring	2	pcs.
00039	3380001	high pressure gasket	3	pcs.
00040	2785451	seal piston	1	pcs.
00041	3038126	o-ring	1	pcs.
00042	3098361	o-ring	2	pcs.
00043	3038361	o-ring	1	pcs.
00044	3380049	high pressure gasket	1	pcs.
00045	3437135	double grooved ring	1	pcs.
00050	2800062	square counter flange	3	pcs.
00052	3380199	flat gasket	1	pcs.
00053	3040224	o-ring	4	pcs.
00055	4500016	double piston slewing gear	1	pcs.
00056	2656655	5/2 way valve	1	pcs.
00056	4206553	coil	1	pcs.

00056	4105912	appliance plug	1	pcs .
00056	2614072	sound absorber	1	pcs .
00057	4200143	limit switch	1	pcs.
00058	2708947	deep groove ball bearing	1	pcs .
00059	2307427	pressure spring	1	pcs .
00060	2656655	5/2 way valve	1	pcs .
00060	4206553	coil	1	pcs .
00060	4105912	appliance plug	1	pcs .
00060	2614072	sound absorber	1	pcs .
00063	5950196	connection box	1	pcs .
00064	8450198	cover for connection box	1	pcs .
00065	4105616	clamp	12	pcs .
00065	4105617	clamp	5	pcs .
00065	4100015	distance plate	3	pcs .
00066	2000258	slotted cheese head screw	2	pcs .
00067	4105805	mounting rail	1	pcs.
00069	4160350	cable gland	8	pcs.
00069	4160349	reducing ring	8	pcs.
00069	4100104	cable gland	1	pcs.
00069	4870017	plug	1	pcs.
00070	2650017	high pressure control device	1	pcs .
00071	2660005	safety valve	1	pcs.
00072	2602689	pressure gauge	1	pcs.
00073	9902572	differential pressure indicator ace . t	1	pcs .
00075	2560063	angle ball valve	2	pcs .
00076	2200235	spring ring	4	pcs .
00077	2002155	hexagon socket head cap screw	2	pcs .
00078	2002155	hexagon socket head cap screw	2	pcs.
00079	2000121	hexagon socket head cap screw	2	pcs.
00080	2000482	stud bolt	4	pcs.
00080	2100011	hexagon nut	4	pcs.
00081	2000155	hexagon socket head cap screw	4	pcs .
00082	2000132	hexagon socket head cap screw	4	pcs.
00083	2000122	hexagon socket head cap screw	4	pcs.
00084	2000158	hexagon socket head cap screw	8	pcs.
00085	2100006	hexagon nut	4	pcs.
00086	2009095	stud bolt	4	pcs .
00087	2009095	stud bolt	8	pcs.
00088	2000122	hexagon socket head cap screw	4	pcs.
00089	2000131	hexagon socket head cap screw	3	pcs .
00090	2000157	hexagon socket head cap screw	2	pcs.
00091	2000144	hexagon socket head cap screw	4	pcs.
00092	2000122	hexagon socket head cap screw	2	pcs .
00093	2000131	hexagon socket head cap screw	2	pcs.
00094	2000261	slotted cheese head screw	2	pcs .
00095	2000001	stud bolt	4	pcs.
00096	2000132	hexagon socket head cap screw	1	pcs.
00097	2209969	spring ring	1	pcs.
00098	2004354	stud bolt	1	pcs.
00099	2100047	hexagon nut	4	pcs .
00100	2100006	hexagon nut	8	pcs.
00101	2100006	hexagon nut	4	pcs.
00102	2003587	threaded flange screw	4	pcs .
00103	2100004	hexagon nut	4	pcs.
00104	2110593	hexagon nut	1	pcs.
00105	2004715	hexagon screw	1	pcs .
00106	5006107	disc	1	pcs.
00107	2200007	disc	1	pcs .
00108	2203399	locking ring	1	pcs .
00109	2200005	disc	2	pcs.

00110	2001578	headless screw	1	pcs .
00111	2209799	spring ring	4	pcs .
00112	2614171	sound absorber	5	pcs .
00113	2100003	hexagon nut	2	pcs .
00114	2608775	non return valve	1	pcs .
00115	2500024	screwing	1	pcs .
00116	2500025	screwing	2	pcs .
00116	2500025	screwing	6	pcs .
00117	2505496	screwing	1	pcs .
00118	2500029	screwing	2	pcs .
00119	2507461	screwing	1	pcs .
00121	2508115	screwing	2	pcs .
00123	2507808	screwing	1	pcs .
00124	2001772	screwed sealing plug	1	pcs .
00124	3275525	gasket	1	pcs .
00125	2000186	screwed sealing plug	1	pcs .
00125	3270001	gasket	1	pcs .
00126	2500083	screwed socket	2	pcs .
00127	2560356	angle ball valve	1	pcs .
00128	0602645	tubing set	1	pcs .
00130	9401690	type plate	1	pcs .
00131	9407569	label: "in / out"	1	pcs .
00131	9400997	label: "on / off"	1	pcs .
00131	9407396	label : "mud drain"	1	pcs .
00131	9402898	label	1	pcs .
00131	9405704	label: " ... 2 lugs ... "	1	pcs .
00131	9403614	label : "compressed air connection"	1	pcs .
00131	9404642	label: "Delta P differential pressure	1	pcs .
00140	4300000	control box according to order	1	pcs .
00150	6705030	key	1	pcs .
00150	6705032	key for unscrewing the filter element	1	pcs .
00150	5700721	guiding bolt	2	pcs .

TYP4.36.2
06.01.98

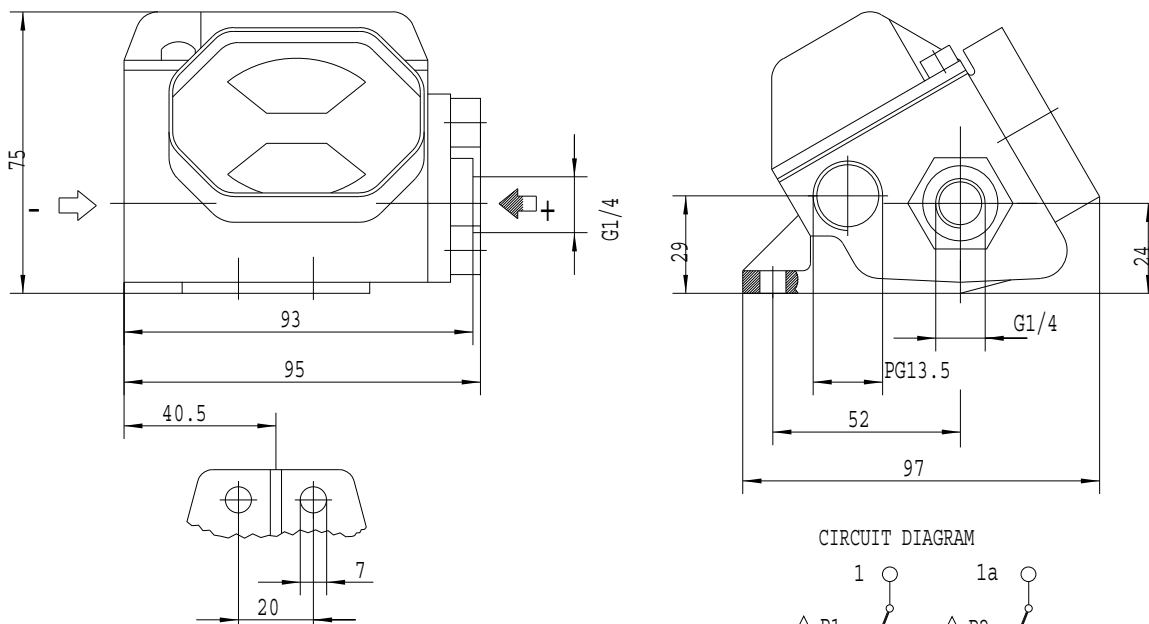

CIRCUIT DIAGRAM

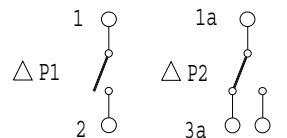

SPECIFICATION:
PROTECTION CLASS: IP 65

ELECTR. DATA: SWITCHING VOLTAGE V= MAX.= 250 220[~]
FREQUENCY HZ MAX.= 0-60 0-60
SWITCHING CURRENT A MAX.= 1 0.8
MAKING AND/OR BREAKING CAPACITY
W/VA MAX.= 60/60 40/60

MATERIAL : GD - ALUMINIUM
RATING : MAX. PRESSURE 100 BAR
MAX. TEMPERATURE 150°C

RANGES OF PRESSURE DIFFERENTIAL :
DELTA P = 0 - 0.5 BAR
0 - 0.8 BAR TO BE SPECIFIED
0 - 1.2 BAR WHEN ORDERING
0 - 2.0 BAR
0 - 3.0 BAR

DESCRIPTION:

THE PURPOSE OF THIS DEVICE IS THE MEASUREMENT, AND VISUAL INDICATION OF THE DIFFERENCE IN PRESSURE BETWEEN TWO POINTS, AND THE ESTABLISHMENT OF AN ELECTRICAL CONTACT WHEN THE PRESSURE DIFFERENTIAL ATTAINS A SPECIFIED FIGURE.

METHOD OF OPERATION:

A PLUNGER SEALED BY A DIAPHRAGM SEPARATES THE SPACE UNDER PRESSURE INTO TWO CHAMBERS. A PRE-LOADED SPRING CAUSES THE PLUNGER TO TAKE UP ITS ZERO POSITION WHEN THE PRESSURE DIFFERENCE DELTA P IS ZERO. AS THE PRESSURE DIFFERENCE INCREASES (DELTA P > 0), THE PLUNGER IS FORCED TO MOVE AGAINST THE SPRING. AT THE SAME TIME, AN INDICATOR DISC IS MOVED MAGNETICALLY, AND THEREFORE VIRTUALLY WITHOUT FRICTION, AND THE TWO REED CONTACTS ARE ACTUATED.

THE RED SEGMENT OF THE INDICATOR DISC IS VISIBLE OVER A PRESSURE RANGE EQUAL TO 20-100% DELTA P . THE FIRST REED CONTACT IS ACTUATED AT 75% DELTA P, AND THE SECOND AT 100% DELTA P.

DIFFERENTIAL PRESSURE CONTACT INDICATOR

3

7

10

11

A

GEKLEBET
CEMENTED
COLLE

BEI BESTELLUNG ANGEBEN
TO BE MENTIONED IN CASE OF ORDER
A MENTIONNER LORS DE LA COMMANDE

AUFTR.NR. :
ORDER NO.
NO DE COMMANDE

TYP 4.36.2

A - B

11	ROLLMEMBRAN	DIAPHRAGM	DIAPHRAGME
10	FEDER	SPRING	RESSORT
7	KOLBEN	PISTON	PISTON
3	DICHTUNG	GASKET	JOINT
POS.NR.	BEZEICHNUNG	DESIGNATION	DESIGNATION

ERSATZTEILZEICHNUNG
SPART PARTS DRAWING

ZUM TYP 4.36.2 UND 4.46.2
PLAN DES PIECES DE RECHANGE

11.02.94

BOLL & KIRCH FILTERBAU GMBH
SIEMENSSTRASSE, 50170 KERPEN-SINDORF

Z21434

31 PRESSURE VESSELS

To ensure faultless operation, check regularly the operation of the pressure relief valve and any other safety devices visually. If a safety device is found damaged it must be replaced. The internal and external condition of the vessel is inspected.

NOTE: The manufacturer of the vessel shall be contacted if it is established that the vessel has been deformed, damaged, corroded, or if its surface coating is torn. Repair measures must be agreed with the manufacturer of the pressure equipment.

NOTE: The decisions of the local pressure equipment authorities in the target country apply for any possible repair and modification work.



1. To avoid damaging the pressure vessel, do not exceed the maximum allowed operating pressure which is shown on the vessel's nameplate. Use the relief valve.
2. Do not exceed the maximum allowed operating temperature which is shown on the pressure vessel's nameplate. As the temperature rises, the pressure rises too. Use the relief valve.
3. Do not touch the surface of the vessel when its internal temperature exceeds 60 °C. The vessel surface is burning hot. Be careful with the hot contents.

A commissioning inspection, i.e. the first periodic service, is performed for pressure vessels which are to be registered. The first periodic inspection is performed by the notified body and the owner or the holder is obliged to apply to the notified body for the performance of the inspection.

32 HOW TO ORDER SPARE PARTS

Identification of needed part

When ordering spare parts, please mention the following:

- 1 Serial number of the unit
(welded on the bottom beam of the unit frame)

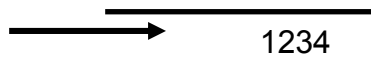

- 2 Part number from the part list

PART NO	
E17011	
E17033	
E17070	

- 3 Serial number of the part to be replaced
(mentioned in the rating plate of the part)



Ordering address:

Auramarine Ltd., After Sales Dept., P.O. Box 849, FIN-20101 TURKU
Fax +358 204 86 5031
Tel +358 204 86 5030

In case of guarantee part(s), please return the damaged part(s) to the above mentioned address.