

Sustainable Development Of Electricity

1. Cdt.Shubham Singhal

(shubhamsinghal1101@Gmail.Com)

Tolani Maritime Institute,Indur

2. Cdt.Rishabh Jangra

Tolani Maritime Institute,Induri

(jangrarishabh96@Gmail.Com)

Abstract

This paper attempts to show that the kinetic energy which is getting lost by the movement of vehicles on speed breaker, can be converted into electrical energy i.e produce power. In our design Electricity is generated by replacing traditional speed breaker with some simple mechanism. The mechanism consists of a lever fitted inside the speed breaker which gets pressed as the vehicle passes over the speed breaker. This inturn converts the rectilinear motion of the lever into the rotatory motion with the help of a gear mechanism .The rotating gears rotate the flywheel fixed on the shaft of DC generator. As a result we get DC from DC generator which can be stored in the batteries and further be utilised as per the need.

Keywords

(Keywords: Vehicle pressure ;Lever ;Gear Mechanism ;DC generator; Batteries.)

1. Introduction

For reduction of carbon dioxide emission, renewable energies are considered as proper alternative energy . Renewable energies mainly refer to the wind, solar, biomass and marine currents which are less harmful to environment.

In many systems and processes, dissipation of energy is inevitable whatever renewable or conventional energy was used. For instance, as a car passes over a speed-breaker, most of car kinetic energy will be wasted as heat in it. On other hand, to ensure the security of the populated areas of streets, the speed-breakers are required.

In this paper, we focus on the fixed speed-breaker at the streets or at ports since a high amount of vehicles kinetic energy is wasting there. There are thousands of crowd cities with enormous flow of vehicles offers high amount of energy can be considered as near to urban resource of energy on the other hand it can utilised on ports as well. Also, extraction of such energy allows elimination of transmission system between the remote areas and urban area for lightings purposes.

This device converts the kinetic energy of the vehicles into electric energy. This is done by moving plate installed on the road, this plate take the stroke motion of the vehicles and convert it to the rotary motion by crank mechanism and it generates the electricity.This device can be installed at ports especially it can act as an innovative tool

to promote the construction of ports for inland waterway projects and prove to be a boon to country's economy. If made in use it will promote the Make In India campaign as well.

PROPOSED SYSTEM DESIGN & OPERATION:

A. System design & configuration

When automobile vehicle are running on the specialized Speed Breaker. This will create pressure on the pressure lever which is kept under specialized speed breaker. As a result flywheel will rotate and this rotation of the flywheel will cause the DC generator to produce electricity. This electricity can be stored by a rechargeable battery by charging the battery. The produced or stored electricity is used for lighting bulb during night time on the road side.

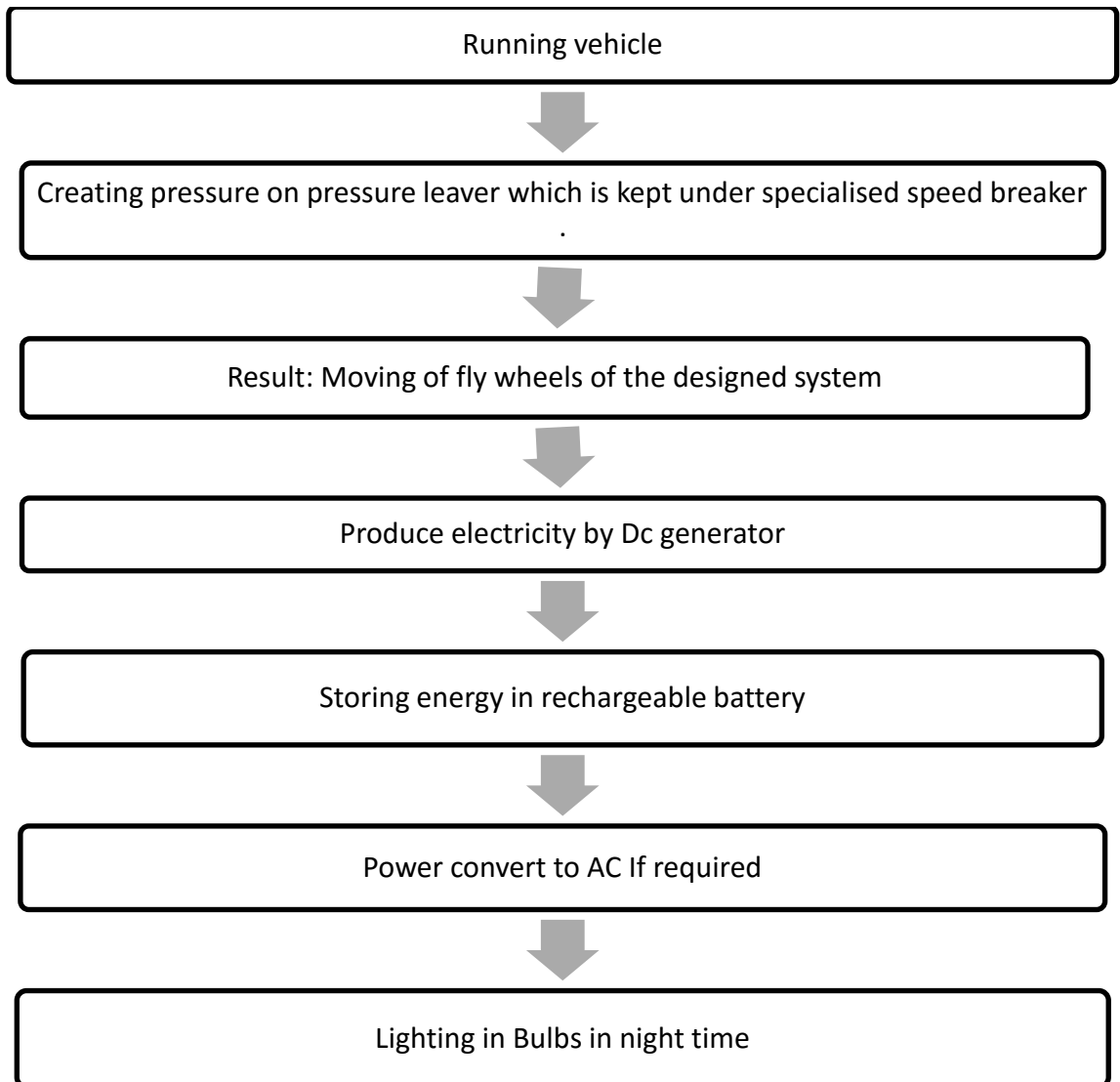

Fig 1:Flow Chart Of Whole Operation

B. Drawing of the project with AUTOCAD: When imposing pressure on the pressure lever the mechanical gears will rotate, and increase the shaft RPM from

shaft 01 to Shaft 05 because these shaft are mechanically coupled with each other. Flywheel and DC Generator are coupled with shaft 05 so flywheel rotates and stores mechanical kinetic energy. This helps to rotate the generator in desired RPM.

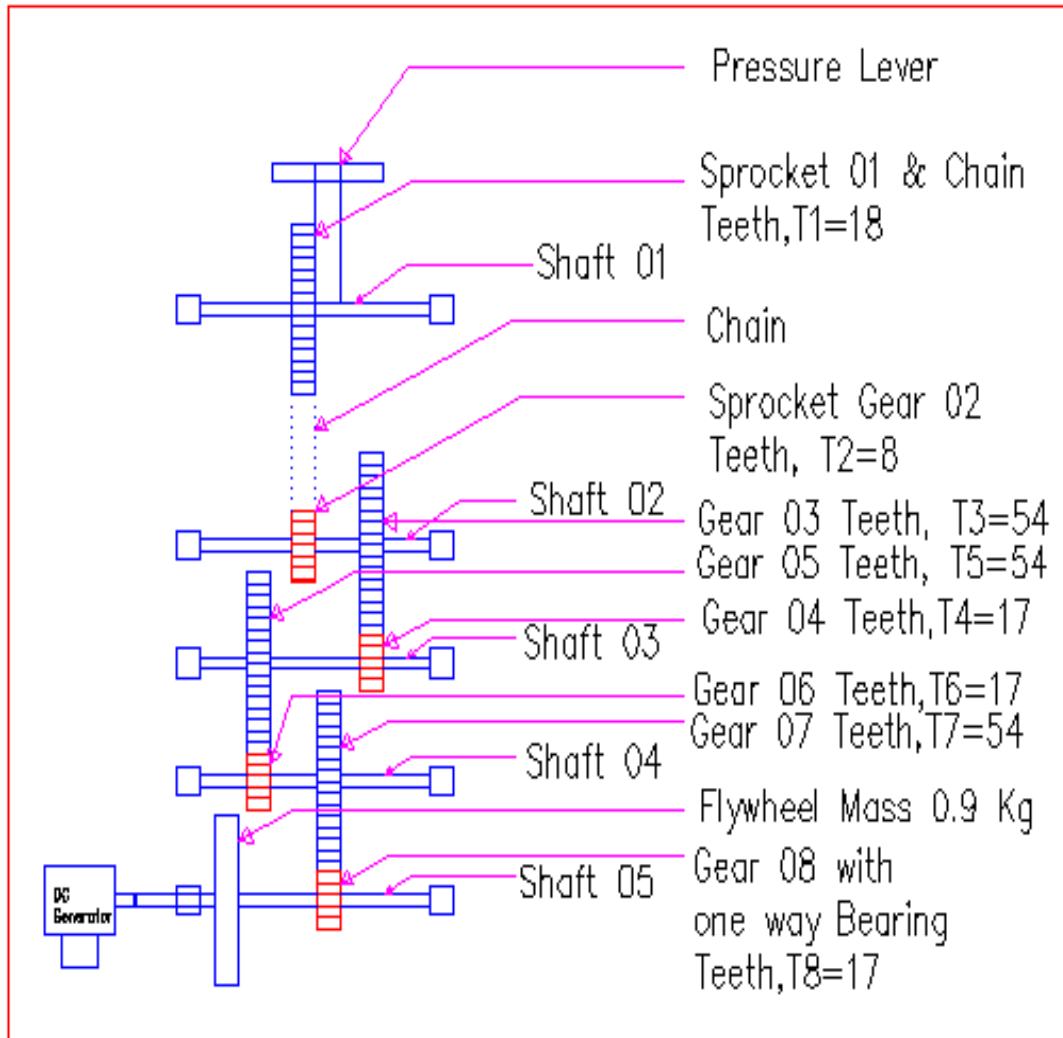

Fig 2: Mechanical Drawing Of The Project

C. Project Electrical Circuit Diagram: Switches that can be turned to different positions to make a connection with the contacts in that particular position. A rechargeable battery, storage battery, or accumulator is a type of electrical battery. It comprises one or more electrochemical cells, and is a type of energy accumulator. It is known as a secondary cell because its electrochemical reactions are electrically reversible. Rechargeable batteries come in many different shapes and sizes, ranging from button cells to megawatt systems connected to stabilize an electrical distribution network. Several different combinations of chemicals are commonly used, including: lead-acid, nickel cadmium (NiCad), nickel metal hydride (NiMH), lithium ion (Li-ion), and lithium ion polymer (Li-ion polymer). When electricity is produced in DC generator, current passes through the rectifier and rechargeable battery is charged.

When power is needed during the night time, selector switch is on and rechargeable battery supplies required power.

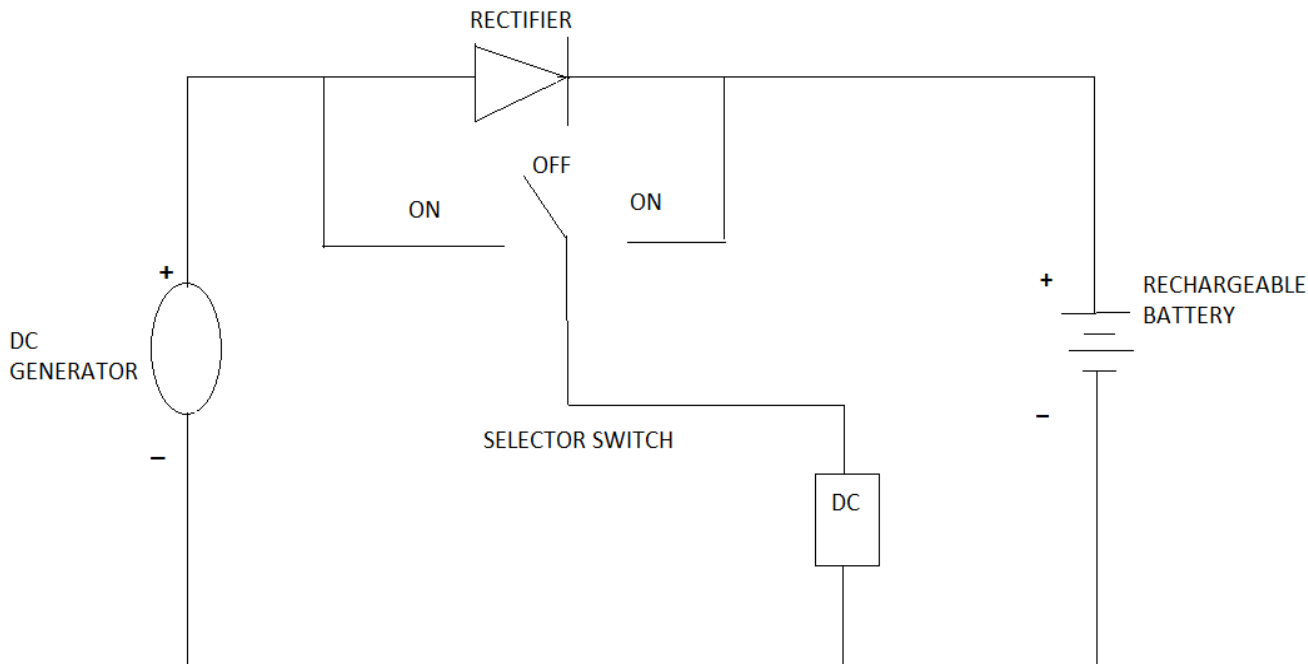

Fig 3. Circuit Diagram

D. Results:

Calculation of input power, output power and efficiency Input power calculation

Applying 07 kg weight on the pressure lever, the lever travels a distance of 0.152 meter (m) and the total time taken to travel this distance is 0.717 second(s) and the RPM for one Stroke is 1014. (Measured by RPM meter). By one stroke sprocket gear moves three teeth from its original position. Gear ratio between sprocket gear 01 & sprocket gear 02

$$N1/N2=T1/T2$$

$$(3/8)/N2=8/18$$

So the calculated N2 becomes

$$N2=3/8$$

As sprocket gear 02 & gear 03 are on the same shaft So revolution of sprocket gear 03,

$$N3=N2=3/8$$

Now gear ratio between gear 03 & gear 04

$$N3/N4=T4/T3$$

$$(3/8)/N4=17/54$$

$$SO, N4=1.19$$

As gear 04 & gear 05 are on the same shaft So revolution of gear 05 becomes,

$$N5=N4=1.19$$

Gear ratio between gear 05 & gear 06,

$$N5/N6=T6/T5$$

$$1.19/N6=17/54$$

So, $N_6 = 3.78$

As gear 06 & gear 07 are on the same shaft So revolution of gear 07 becomes, $N_7 = N_6 = 3.78$

Gear ratio between gear 07 & gear 08

$$N_7/N_8 = T_8/T_7$$

$$3.78/N_8 = 17/54$$

$$N_8 = 12.01 = 12 \text{ (APPOX.)}$$

So the gear ratio between gear 01 & gear 08

$$N_1:N_8 = (3/8):12$$

The flywheel, gear 08 & DC generator shaft are connected on the same shaft So RPM of DC generator shaft becomes $= (12 * 60) / 0.717$

$$\text{RPM} = 1004.1$$
 We know,

Work done, $W = F * S$ Where, $F = \text{force}$ & $S = \text{distance travel}$

$W = mg * s$ Where, $m = \text{mass}$ & $g = \text{gravitational acceleration}$

$$W = 7 * 9.81 * 0.152 = 10.43 \text{ Joule (j)}$$

Input Power, $P = \text{Total work done} / \text{total time taken to do the work}$

$$\text{So, } P = W/t \text{ } P_i = 10.43/0.717 = 14.55 \text{ Watt (w)}$$

Output Power Calculation

Output power, $P_o = \text{Voltage} * \text{Current}$

$$\text{Output power, } P_o = V * I = 4.0 * 0.5 = 2 \text{ Watt (W)}$$

Efficiency Calculation

Efficiency = $(\text{Output Power} / \text{Input Power}) * 100 \%$

$$\text{Efficiency} = (2/14.55) * 100\% = 13.75 \%$$

From the results discussed above it is seen that the input power was 14.55W and the founded power at the output is 2W, so the resulted efficiency becomes 13.75% which is much better.

E. ADVANTAGES:

- Generation of power without polluting the environment.
- Simple construction and easy maintenance.
- No fuel required.
- No consumption of any fossil fuel which is non-renewable source of energy.
- No external source is needed for power generation.

CONCLUSION

In coming days, it will prove a great boon to the world, since it will save a lot of electricity of power plants that gets wasted in illuminating the street lights. As the conventional source are depleting very fast, then it's time to think of alternatives. We got to save the power gained from the conventional sources for efficient use. So this idea not only provides alternative but also adds to the economy of the country. Now vehicular traffic in big cities is more, causing a problem to human being. But this vehicular traffic can be utilized for proper use by taking this specialised speed breaker into use. It has advantages that it does not utilize any external source. Now the time has come to put forte this type of innovative ideas, and also researches should be done to upgrade its implication. In future, if the flywheel speed control device and voltage protection devices are added with large generation process, it would be a model all over the world. After some modification of the designed project, the efficiency of the whole

system can be increased by increasing the capacity of the generator and applying more weight.

Acknowledgment:

First of all we want to acknowledge our collage the TOLANI MARITIME INSTITUTE which gave us the opportunity to work on such technical event through Trantech. We are also grateful to our supportive faculties who were always there to help us at the time of difficulty. Special thanks to all of those with whom we have had pleasure to work during this project.

References:

- [1] Mukherje, D., Chakrabarti, S., Non-conventional power plants, New Delhi, 2005.
- [2] Shakun Srivastava, Ankit asthana, “produce electricity by the use of speed breakers,” Journal of Engineering Research and Studies, Vol.2, No.1 April-Jun 2011.
- [3] Selvaraj, R.S., Sivamadhavi, V., “Magnitude of Green House Effect and the contribution of Carbon di oxide,” Recent Advances in Space Technology Services and Climate Change (RSTSCC), 13-15 Nov. 2010, no. 41 – 44, Chennai.
- [4] Sharma, P.C., “Principles of renewable energy systems”, 2003.
- [5] Nota, R., Barelds, R., “Engineering methods for road traffic and railway noise after validation and fine-tuning”, Harmonies, 2005.
- [6] Watts. “Effects of speed distribution on the Harmonies model predictions”, Inter-noise Conference, Prague, 2004.