

Pressure controls and thermostats
Type KPS

Pressure controls and thermostats, type KPS

Survey

Type KPS pressure controls

1. Standard pressure controls

-1	0	10	20	30	40	50	60	bar	Range P_e bar	Type	Further information page
									0 - 2.5	KPS 31	3
									0 - 3.5	KPS 33	3
									0 - 8	KPS 35	3
									6 - 18	KPS 37	3
									10 - 35	KPS 39	3

2. Type KPS pressure controls for high pressure and strongly pulsating media

-1	0	10	20	30	40	50	60	bar	Range P_e bar	Type	Further information page
									1 - 10	KPS 43	3
									4 - 40	KPS 45	3
									6 - 60	KPS 47	3

Thermostats

-50	0	50	100	150	200	250	°C	Range °C	Type	Further information page
								-10 - +30	KPS 76	8
								20 - 60	KPS 77	8
								50 - 100	KPS 79	8
								70 - 120	KPS 80	8
								60 - 150	KPS 81	8
								100 - 200	KPS 83	8

ISO 9001 quality approval

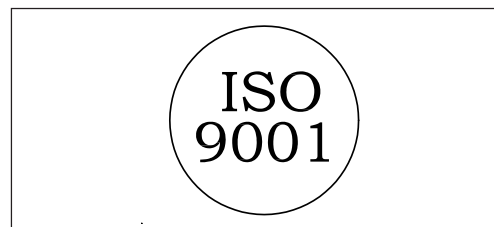

Danfoss A/S is certified by BSI in accordance with international standard ISO 9001. This means that Danfoss fulfils the international standard in respect of product development, design, production and sale. BSI exercises continuous inspection to ensure that Danfoss observes the requirements of the standard and that Danfoss' own quality assurance system is maintained at the required level.

Pressure controls and thermostats, type KPS

Introduction

KPS units are pressure-controlled switches. The position of the contacts depends on the pressure in the inlet connection and the set scale value. In this series, special attention has been given to meeting important demands for:

- a high level of enclosure,
- robust and compact construction,
- resistance to shock and vibration.

The KPS series covers most outdoor as well as indoor application requirements. KPS pressure controls are suitable for use in alarm and regulation systems in factories, diesel plant, compressors, power stations and on board ship.

Technical data and ordering

When ordering, please state type and code number



KPS 31, 33



KPS 35, 37, 39



KPS 43, 45, 47

1. Pressure controls

Setting range p_s [bar]	Adjustable/ fixed differential [bar]	Permissible operating pressure P_B [bar]	Max. test pressure [bar]	Pressure connection	Code no.	Type
0 → 2.5	0.1	6	6	G 1/4	060-3110	KPS 31
0 → 2.5	0.1	6	6	G 3/8 A	060-3109	KPS 31
0 → 3.5	0.2	10	10	G 1/4	060-3104	KPS 33
0 → 3.5	0.2	10	10	G 3/8 A	060-3103	KPS 33
0 → 8	0.4 - 1.5	12	12	G 1/4	060-3105	KPS 35
0 → 8	0.4 - 1.5	12	12	G 3/8 A	060-3100	KPS 35
0 → 8	0.4	12	12	G 1/4	060-3108	KPS 35
6 → 18	0.85 - 2.5	22	27	G 1/4	060-3106	KPS 37
6 → 18	0.85 - 2.5	22	27	G 3/8 A	060-3101	KPS 37
10 → 35	2.0 - 6	45	53	G 1/4	060-3107	KPS 39
10 → 35	2.0 - 6	45	53	G 3/8 A	060-3102	KPS 39

2. Pressure controls for high pressure and strongly pulsating media

Setting range p_s [bar]	Adjustable diff. (see also figs. 1, 2 and 3) [bar]	Permissible overpressure [bar]	Max. test pressure [bar]	Min. bursting pressure [bar]	Pressure connection	Code no.	Type
1 → 10	0.7 - 2.8	120	180	240	G 1/4	060-3120	KPS 43
4 → 40	2.2 - 11	120	180	240	G 1/4	060-3121	KPS 45
6 → 60	3.5 - 17	120	180	240	G 1/4	060-3122	KPS 47

Terminology

Range setting

The pressure range within which the unit will give a signal (contact changeover).

Differential

The difference between make pressure and break pressure (see also fig. 8, page 7).

Permissible overpressure

The highest permanent or recurring pressure the unit can be loaded with.

Max. test pressure

The highest pressure the unit may be subjected to when, for example, testing the system for leakage. Therefore, this pressure must not occur as a recurring system pressure.

Min. bursting pressure

The pressure which the pressure-sensitive element will withstand without leaking.

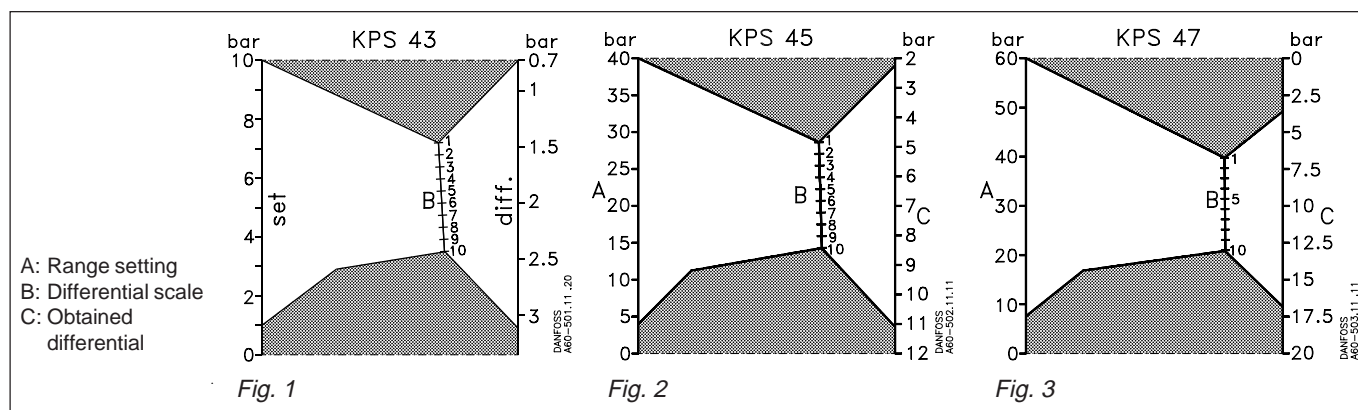

Pressure controls and thermostats, type KPS

Switch

Single pole changeover (SPDT)
Contact material: Gold-plated silver contact

Contact load

- Alternating current:
 - Ohmic: 10 A, 440 V, AC-1
 - Inductive: 6 A, 440 V, AC-3
4 A, 440 V, AC-15
 - Starting current max. 50 A (locked rotor)
- Direct current: 12 W, 220 V, DC-13
See curve, fig. 4

Ambient temperature

KPS 31 - 39: -40 to +70 °C
KPS 43 - 47: -25 to +70 °C

Temperature of medium

KPS 31 - 39: -40 to +100 °C
KPS 43 - 47: -25 to +100 °C
For water and seawater, max. 80°C.

Vibration resistance

Vibration-stable in the range 2-30 Hz, amplitude 1.1 mm og 30-300 Hz, 4 G.

Enclosure

IP 67 to IEC 529 an DIN 40050.
The pressure control housing is enamelled pressure die cast aluminium (GD-AISI 12). The cover is fastened by four screws which are anchored to prevent loss. The enclosure can be sealed with wire.

Cable entry

Pg 13.5 for cable diameters from 5 to 14 mm.

Identification

The type designation and code no. of the unit is stamped in the side of the housing.

Scale accuracy

KPS 31: ±0.2 bar	KPS 39: ±3.0 bar
KPS 33: ±0.3 bar	KPS 43: ±1.0 bar
KPS 35: ±0.5 bar	KPS 45: ±4.0 bar
KPS 37: ±1.0 bar	KPS 47: ±6.0 bar

Mean value of snap point variation after 400 000 operations

KPS 31: ±0.1 bar	KPS 39: ±0.7 bar
KPS 33: ±0.2 bar	KPS 43: ±0.2 bar
KPS 35: ±0.3 bar	KPS 45: ±1.0 bar
KPS 37: ±0.4 bar	KPS 47: ±1.5 bar

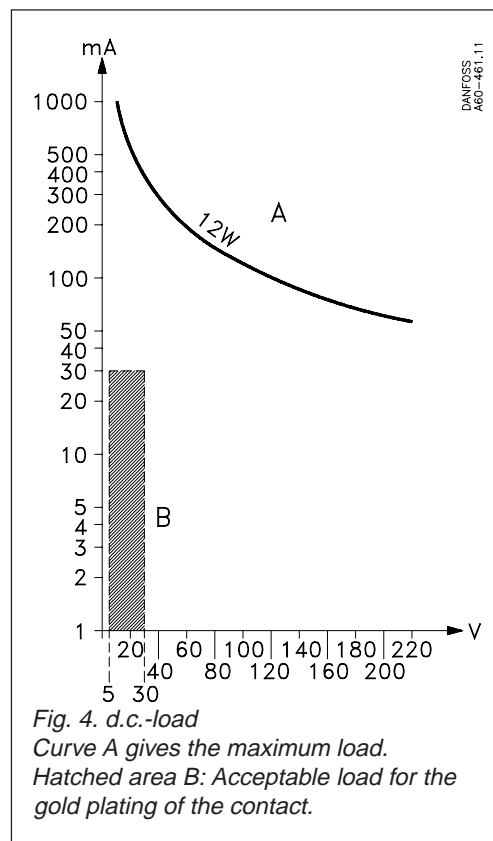

Materials in contact with the medium

KPS 31, 33	Bellows capsule: Bellows: Pressure connection:	Deep-drawn plate, Stainless steel, Steel C20,	material no. 1.0524 (DIN 1624) material no. 1.4306 (DIN 17440). material no. 1.0420 (DIN 1652)
KPS 35, 37,39	Bellows: Pressure connection:	Stainless steel, Brass,	material no. 1.4306 (DIN 17440) W.No. 2.0401 (DIN 17660)
KPS 43, 45, 47	Diaphragm capsule: Diaphragm:	Nickel-plated brass, Nitrile-Butadien rubber	DIN 50 968 Cu/Ni 5 (DIN 1756)

Approvals

EN 60 947-4-1
EN 60 947-5-1

U Underwriters Laboratories Inc., USA

Ship approvals

Det norske Veritas, Norway
American Bureau of Shipping
Lloyds Register of Shipping, UK
F Germanischer Lloyd, Federal Republic of Germany (FRG)
Bureau Veritas, France
Includes thermostats with fixed sensor and pressure controls with armoured capillary tube.

P Registro Italiano Navale, Italy
Polski Rejestr Statków, Poland
MRS, Maritime Register of Shipping, Russia
Nippon Kaiji Kyokai, Japan

Pressure controls and thermostats, type KPS

Accessories

Part		Description	Code no.
Connector with nipple		G $\frac{3}{8}$ connector, nipple and washer (10 mm o.d. x 6.5 mm i.d.), for brazing	017-4368
Connector with nipple		G $\frac{3}{8}$ connector, nipple and washer (10 mm o.d. x 6.5 mm i.d.) for welding	017-4229
Reducer		G $\frac{3}{8}$ x $\frac{7}{16}$ - 20 UNF ($\frac{1}{4}$ flare) reduction with washer	017-4205
Adaptor		G $\frac{3}{8}$ x $\frac{1}{8}$ - 27 NPT with washer	060-3334
Nipple		R $\frac{3}{8}$ o.d x $\frac{7}{16}$ - 20 UNF ($\frac{1}{4}$ flare)	060-3240
Nipple		G $\frac{3}{8}$ A - $\frac{1}{4}$ NPT with washer	060-3335
Adaptor		G $\frac{3}{8}$ x $\frac{1}{4}$ - 18 NPT with washer	060-3336
Nipple		G $\frac{1}{4}$ A x G $\frac{3}{8}$ A	060-3332
		G $\frac{1}{4}$ A x o.d. M10 x 1 with washer	060-3338
Damping coil		Damping coil with $\frac{1}{4}$ flare connectors and 1 m copper capillary tube. Damping coils used for applications with $\frac{3}{8}$ RG connector requires the use of reducer, type no. 993N3551 . For informations about capillary tube lengths, please contact Danfoss	060-0071
Damping coil		Damping coil with G $\frac{3}{8}$ connectors and 1.5 m copper capillary tube	060-1047
Armoured damping coil		Damping coil with G $\frac{3}{8}$ connectors and 1 m armoured copper capillary tube. Standard washers included.	060-3333

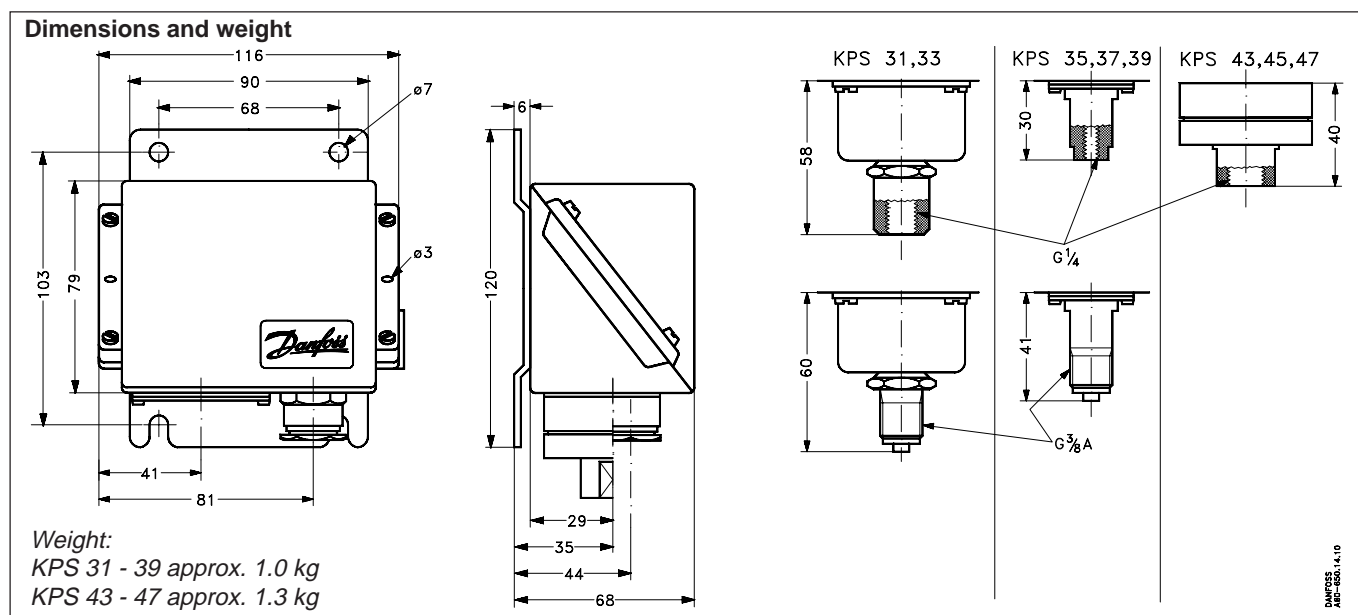

Installation

Installation

KPS pressure controls are fitted with a 3 mm steel mounting plate. The units should not be allowed to hang from the pressure connection.

Pressure connection

When fitting or removing pressure lines, the spanner flats on the pressure connection should be used to apply counter-torque.

Steam plant

To protect the pressure element from excessive heat, the insertion of a water-filled loop is recommended. The loop can, for example, be made of 10 mm copper tube as shown in fig. 5.

Setting

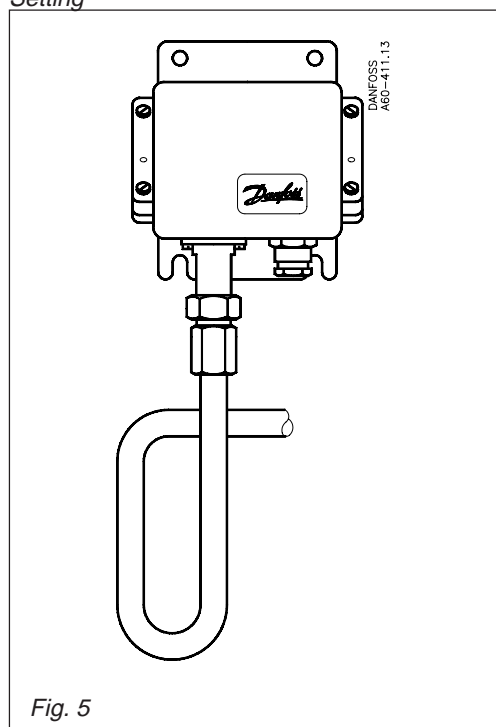

Fig. 5

Water systems

Water in the pressure element is not harmful, but if frost is likely to occur a water-filled pressure element may burst. To prevent this happening, the pressure control can be allowed to operate on an air cushion.

Media-resistance

See table of materials in contact with the medium, page 4. If seawater is involved, types KPS 43, 45, 47 are recommended.

Pulsations

If the pressure medium is superimposed with severe pulsations, which occur in automatic sprinkler systems (fire protection), fuel systems for diesel motors (priming lines), and hydraulic systems (e.g. propeller systems), etc., types KPS 43,45,47 are recommended. The maximum permissible pulsation level for these types is 120 bar.

When the pressure control cover is removed, and the locking screw (5) is loosened, the range can be set with the spindle (1) while at the same time the scale (2) is being read. In units having an adjustable differential, the spindle (3) must be used to make the adjustment. The differential obtained can be read direct on the scale (4) or, with types KPS 43, 45, 47, can be determined by reading the scale value and using the nomograms in figs. 1, 2, 3 (page 3). The working line for determining the differential must not intersect the shaded areas in the nomograms.

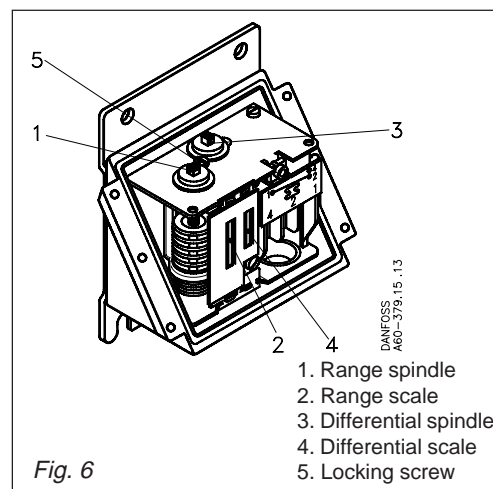

Fig. 6

Selection of differential

To ensure that the plant functions properly, a suitable differential pressure is necessary. Too small a differential will give rise to short running periods with a risk of hunting. Too high a differential will result in large pressure oscillations.

Electrical connection

KPS pressure controls are fitted with a Pg 13.5 screwed cable entry that is suitable for cable diameters from 5 to 14 mm. GL approval is however conditional on the use of a special ship's cable entry. Contact function is shown in fig. 7.

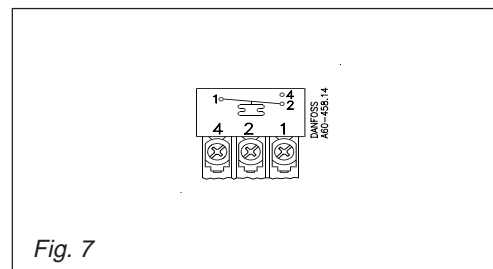

Fig. 7

Pressure controls and thermostats, type KPS

Function

1. KPS 31

Contacts 1-2 make and contacts 1-4 break when the pressure falls under the set range value. The contacts changeover to their initial position when the pressure again rises to the set range value plus the differential (see fig. 8).

- I. Alarm for falling pressure given at the set range value.
- II. Alarm for rising pressure given at the set range value plus the differential.

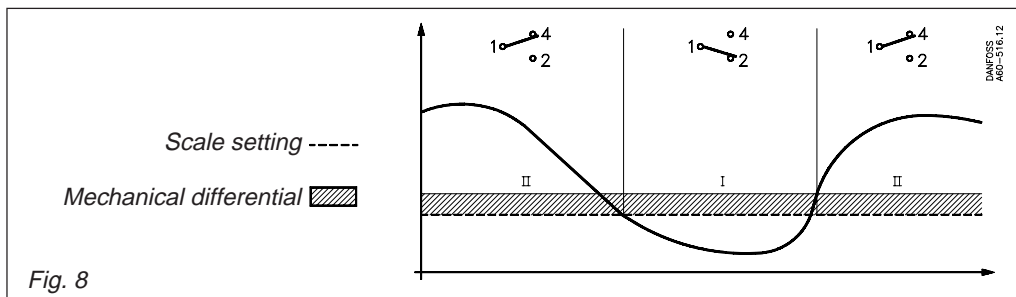

2. All other KPS pressure controls

Contacts 1-4 make and contacts 1-2 break when the pressure rises above the set range value. The contacts changeover to their initial position when the pressure again falls to the range value minus the differential (see fig. 9).

- I. Alarm for rising pressure given at the set range value.
- II. Alarm for falling pressure given at the set range value minus the differential.

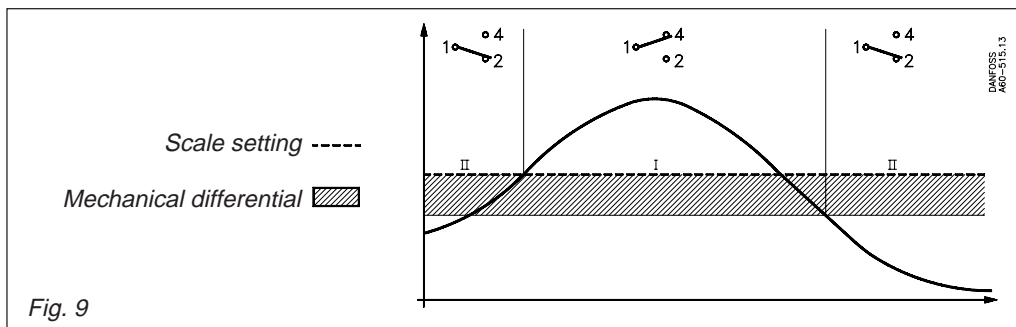

Example 1

An alarm must be given when the lubricating oil pressure in a motor fails below 0.8 bar. The alarm is in the form of a lamp. Choose a KPS 31 (range 0 to 2.5 bar). The minimum permissible lubricating oil pressure of 0.8 bar must be set on the range spindle. The differential is fixed at 0.1 bar, i.e. the alarm will not cut out before the pressure rises to 0.9 bar. The lamp must be connected to terminals 1 and 2 in the pressure control.

Example 2

An alarm must be given by a bell when the pressure in a boiler rises to 10 bar. The normal operating pressure is 9 bar. Choose a KPS 36 (range from 6 to 18 bar). The range value of the pressure control must be set at 10 bar, the differential at 1 bar. The bell must be connected to terminals 1 and 4.

Example 3

The pressure in a start air reservoir must be regulated with a compressor controlled by a KPS pressure control so that it lies between 30 and 36 bar.

Choose a KPS 45 (range 4 to 40 bar). The range value must be set at 36 bar. The differential of 6 bar must be set in accordance with the nomogram, fig. 10, at approx. 2 on the differential scale. The required start function is obtained by connection to terminals 1 and 2 in the pressure control.

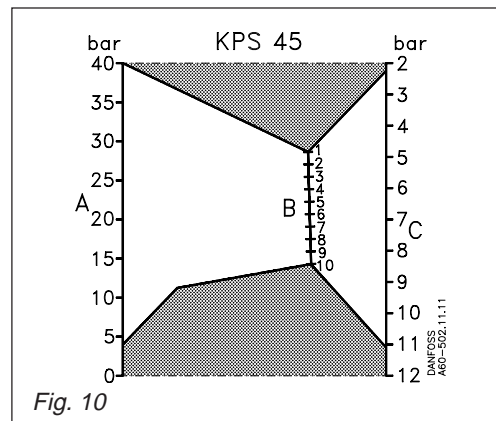

Pressure controls and thermostats, type KPS

Thermostats, introduction

KPS thermostats are temperature-controlled switches. The position of the contacts depends on the temperature of the sensor and the set scale value. In this series, special attention has been given to meeting demands for :

- a high level of enclosure,
- robust and compact construction,
- resistance to shock and vibration.

The KPS series covers most outdoor as well as indoor application requirements.

KPS thermostats are suitable for use in monitoring, alarm and regulation systems in factories, diesel plant, compressors, power stations and on board ship.

Technical data and ordering

When ordering, please state type and code number



KPS with rigid sensor



KPS with remote sensor

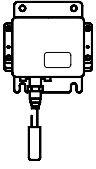
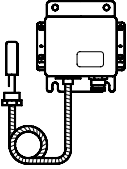
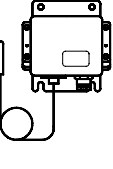

KPS with remote sensor and armoured capillary tube

Setting range °C	Mech. diff. adjustable/ fixed °C	Max. sensor temp. °C	Suitable sensor length (see also "Accessories") mm				Cap. Tube length m	Code nos.			Type
											
-10- 30	3-10	80	65	75	110	160	2		060L3112	060L3113	KPS 76
20- 60	3-14	130	-	75	-	-	-	060L3118			KPS 77
20- 60	3-14	130	-	-	110	-	-	060L3100			KPS 77
20- 60	3-14	130	-	-	-	160	-	060L3136			KPS 77
20- 60	3-14	130	65	75	110	160	2	-	060L3101	060L3102	KPS 77
20- 60	3-14	130	-	-	110	160	5		060L3119	060L3120	KPS 77
50-100	4-16	200	-	75	-	-	-	060L3121			KPS 79
50-100	4-16	200	-	-	110	-	-	060L3103			KPS 79
50-100	4-16	200	-	-	-	160	-	060L3137			KPS 79
50-100	4-16	200	65	75	110	160	2		060L3104	060L3105	KPS 79
50-100	4-16	200	-	-	110	160	5		060L3122	060L3123	KPS 79
50-100	4-16	200	-	-	110	160	8		060L3124	060L3125	KPS 79
50-100	4-16	200	-	75	110	160	3		060L3143		KPS 79
50-100	9	200	-	75	-	-	-	060L3141¹⁾			KPS 79
70-120	4.5-18	220	-	75	-	-	-	060L3126			KPS 80
70-120	4.5-18	220	-	-	110	-	-	060L3127			KPS 80
70-120	4.5-18	220	-	-	-	160	-	060L3138			KPS 80
70-120	4.5-18	220	-	-	-	200	-	060L3157			KPS 80
70-120	4.5-18	220	65	75	110	160	2		060L3128	060L3129	KPS 80
70-120	4.5-18	220	-	75	110	160	3		060L3156		KPS 80
70-120	4.5-18	220	-	-	110	160	5		060L3130	060L3131	KPS 80
70-120	4.5-18	220	-	-	110	160	8		060L3132	060L3133	KPS 80
60-150	5-25	250	65	75	110	160	2		060L3106	060L3107	KPS 81
60-150	5-25	250	-	-	110	160	5		060L3134	060L3135	KPS 81
60-150	5-25	250	-	-	110	160	8		060L3111		KPS 81
60-150	5-25	250	-	-	200	-	-	060L3110			KPS 81
100-200	6.5-30	300	65	75	110	160	2		060L3108	060L3109	KPS 83
100-200	18	300	65	75	110	160	2		060L3139¹⁾	060L3140¹⁾	KPS 83

1) Thermostat with max. reset.

Approvals

EN 60 947-4-1
EN 60 947-5-1

U Underwriters Laboratories Inc., USA

Ship approvals

Det norske Veritas, Norway
American Bureau of Shipping
Lloyds Register of Shipping, UK
F Germanischer Lloyd, Federal Republic of Germany (FRG)
Bureau Veritas, France
Includes thermostats with fixed sensor and pressure controls with armoured capillary tube.

P Registro Italiano Navale, Italy
Polski Rejestr Statków, Poland
MRS, Maritime Register of Shipping, Russia
Nippon Kaiji Kyokai, Japan

Pressure controls and thermostats, type KPS

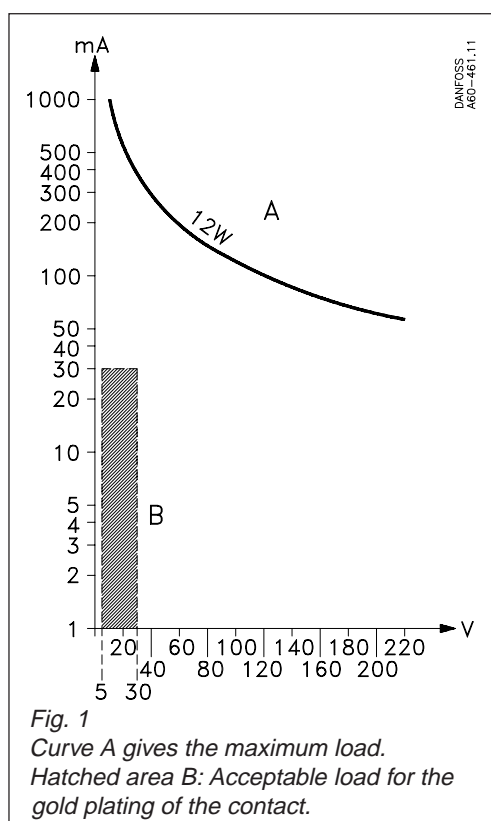

Contact load (Alternating current):

Ohmic: 10 A, 440 V, AC-1
 Inductive: 6 A, 440 V, AC-3
 4 A, 440 V, AC-15

Starting current max. 50 A (locked rotor)

Ambient temperature -40 to $+70$ °C

Vibration resistance

Vibration-stable in the range 2-30 Hz, amplitude 1.1 mm og 30-300 Hz, 4 G.

Enclosure

IP 67 to IEC 529 and DIN 40050.
 The thermostat housing is enamelled pressure die cast aluminium (GID-AISI 12). The cover is fastened by four screws which are anchored to prevent loss.
 The enclosure can be sealed with fuse wire.

Cable entry

Pg 13.5 for cable diameters from 5 to 14 mm.

Identification

The type designation and code no. of the unit is stamped in the side of the housing,

Scale accuracy

KPS 76: ± 3 °C	KPS 80: ± 3 °C
KPS 77: ± 3 °C	KPS 81: ± 6 °C
KPS 79: ± 3 °C	KPS 83: ± 6 °C

Switch

Single-pole changeover switch (SPDT).

Contact material: Gold-plated silver contact.

Direct current: 12 W, 220 V, DC-13 – See fig. 1

Snap point variation after 400 000 operations.
 KPS 76-83: max. drift 2 °C.

Accessories: Sensor pockets for KPS-thermostats	Sensor pocket	A mm	Thread B	Code no.	Sensor pocket	A mm	Thread B	Code no.
<p>Supplied without gland nut, gaskets and washer</p>	Brass	65	1/2 NPT	060L3265				
	Brass	75	1/2 NPT	060L3264	Steel 18/8	75	G 1/2 A	060L3267
		75	G 1/2 A	060L3262				
		75	G 3/4 A	060L3266				
		75	G 1/2 A (ISO 228/1)	060L3281				
	Brass	110	1/2 NPT	060L3280	Steel 18/8	110	G 1/2 A	060L3268
		110	G 1/2 A	060L3271				
		110	G 3/4 A (ISO 228/1)	060L3406				
	Brass	160	G 1/2 A	060L3263	Steel 18/8	160	G 1/2 A	060L3269
		160	G 1/2 A (ISO 228/1)	060L3407				
		160	G 3/4 A (ISO 228/1)	060L3405				
	Brass	200	G 1/2 A	060L3206	Steel 18/8	200	G 1/2 A	060L3237
200		G 1/2 A (ISO 228/1)	060L3408					
200		G 3/4 A (ISO 228/1)	060L3402					
Brass	250	G 1/2 A	060L3254					
Brass	330	G 1/2 A	060L3255					
Brass	400	G 1/2 A	060L3256					
Brass	500	G 1/2 A	060L3257					

Part	Description	No. of per unit	Code no.
Clamping band	For KPS thermostats with remote sensor (L = 392 mm)	X	017-4204
Heat-conductive compound (4.5 cm ² tube)	For KPS thermostats with sensor fitted in a sensor pocket. Compound for filling sensor pocket to improve heat transfer between pocket and sensor. Application range for compound: -20 to $+150$ °C, momentarily up to 220 °C.	As required	41E0110

Pressure controls and thermostats, type KPS

Dimensions and weight

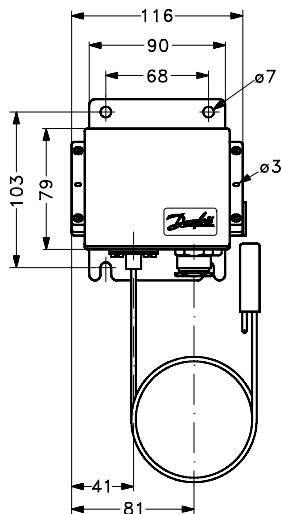

KPS with rigid sensor
Weight: ca 1.0 kg

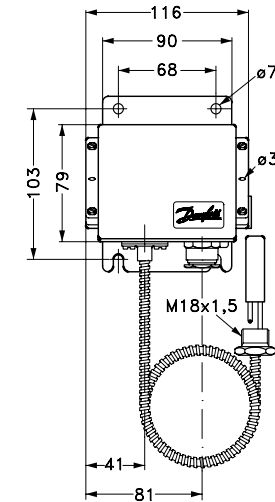
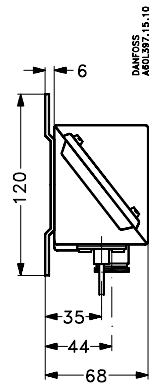

KPS with remote sensor and armoured capillary tube
Weight : ca 1.4 kg (incl. 2 m capillary tube)

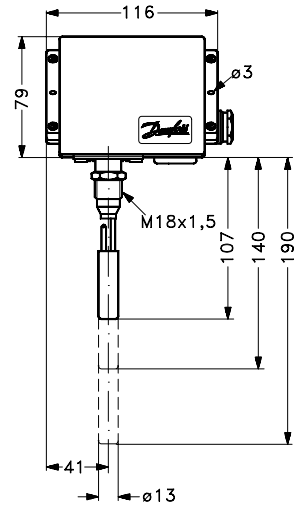
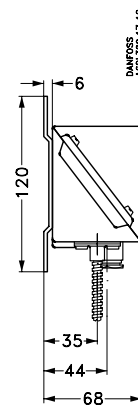

KPS with remote sensor
Weight: ca 1.2 kg (incl. 2 m capillary tube)

Installation

Installation

Location of unit: KPS thermostats are designed to withstand the shocks that occur, e.g. in ships, on compressors and in large machine installations. KPS thermostats with remote sensor are fitted with a base of 3 mm steel plate for fixing to bulkheads, etc. KPS thermostats with bulb sensor are self-supporting from the sensor pocket.

Resistance to media

Material specifications for sensor pockets:

Sensor pocket, brass

The tube is made of Ms 72 to DIN 17660, the threaded portion of So Ms 58Pb to DIN 17661.

Sensor pocket, stainless steel 18/8

Material designation 1.4305 to DIN 17440.

Sensor position

As far as possible the sensor should be positioned so that its longitudinal axis is at right angles to the direction of flow. The active part of the sensor is Ø13 mm x 50 mm long on thermostats with rigid sensors and 2 m capillary tube. The active length on the other thermostats is 70 mm (5 m and 8 m capillary tubes).

The medium

The fastest reaction is obtained from a medium having high specific heat and high thermal conductivity. It is therefore advantageous to use a medium that fulfills these conditions (provided there is a choice).

flow velocity of the medium is also of significance. (The optimum flow velocity for liquids is about 0.3 m/s).

For permissible media pressure see fig. 2.

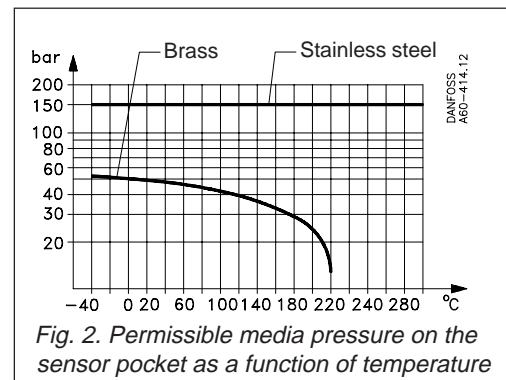

Fig. 2. Permissible media pressure on the sensor pocket as a function of temperature

Setting

When the thermostat cover is removed, and the locking screw (5, fig. 3) is loosened, the range can be set with the spindle (1) while at the same time the scale (2) is being read. In units having an adjustable differential, the spindle (3) can be used while the scale (4) is being read.

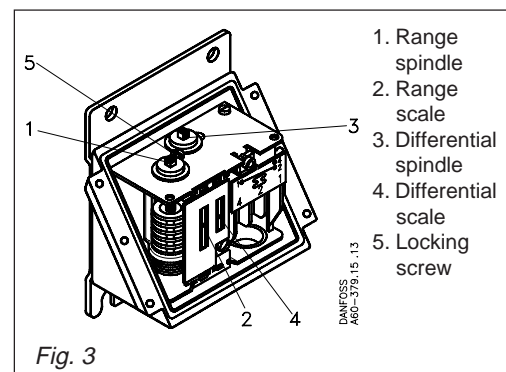

Fig. 3

Pressure controls and thermostats, type KPS

Scale correction

The sensor on KPS thermostats contains an adsorption charge. Therefore function is not affected whether the sensor is placed warmer or colder than the remaining part of the thermostatic element (bellows and capillary tube). However, such a charge is to some extent sensitive to changes in the temperature and bellows and capillary tube. Under normal conditions this is of no importance, but if the thermostat is to be used in extreme ambient temperatures there will be a scale deviation. The deviation can be compensated for as follows:

$$\text{Scale correction} = Z \times a$$

Z can be found from fig. 4, while **a** is the correction factor from the table below.

Type	Regulation range °C	Correction factor a for thermostats		
		with rigid sensor	with 2 and 5 m cap.tube	with 8 m cap.tube
KPS 76	-10 - +30		1.1	
KPS 77	20 - 60	1.0	1.4	
KPS 79	50 - 100	1.5	2.2	2.9
KPS 80	70 - 120	1.7	2.4	3.1
KPS 81	60 - 150		3.7	
KPS 83	100 - 200		6.2	

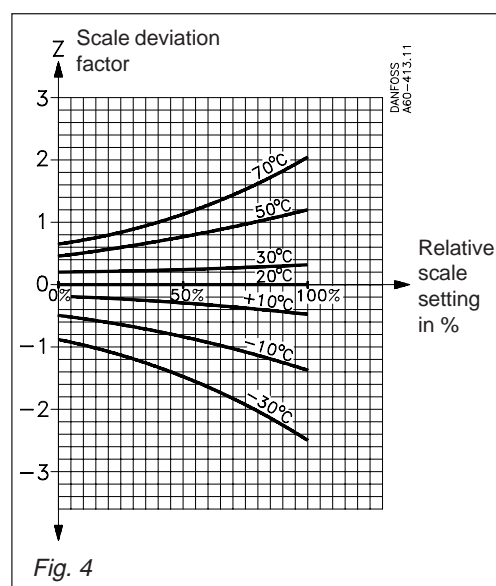

Fig. 4

Electrical connection

KPS thermostats are fitted with a Pg 13.5 screwed cable entry suitable for cables from 5 to 14 mm. GL approval is conditional on the use of a ship's cable entry.

Contact function is shown in Fig. 5

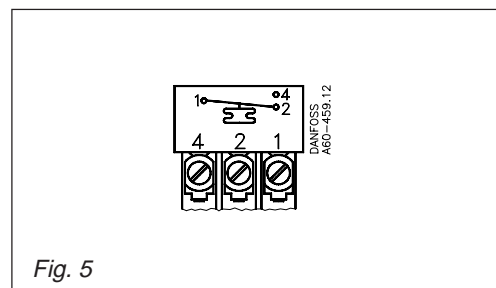

Fig. 5

Examples

Example 1

A diesel engine with cooling water temperature of 85 °C (normal). An alarm must be triggered if the cooling water temperature exceeds 95 °C.

Choose a KPS 80 thermostat (range 70 to 120 °C).

Main spindle setting: 95 °C.

Differential spindle setting: 5 °C.

The required alarm function is obtained by connecting to thermostat terminals 1-4. After the system has been in operation, assess the operating differential and make a correction if necessary.

Example 2

Find the necessary scale correction for a KPS 80 set at 95 °C in 50 °C ambient temperature.

The relative scale setting Z can be calculated from the following formula:

$$\frac{\text{Setting value} - \text{min. scale value}}{\text{max. scale value} - \text{min. scale value}} \times 100 = \%$$

$$\text{Relative scale setting: } \frac{95 - 70}{120 - 70} \times 100 = 50\%$$

Factor for scale deviation Z (fig. 4 page 11),
Z ≈ 0.7

Correction factor **a** (table under fig. 4 page 11) = 2.4

Scale correction = Z × a = 0.7 × 2.4 = 1.7 °C
The KPS must be set at 95 + 1.7 = 96.7 °C

Pressure controls and thermostats, type KPS

Function

Selection of differential

To ensure that the plant functions properly, a suitable differential is necessary. Too small a differential will give rise to short running periods with a risk of hunting. Too high a differential will result in large temperature variations

The thermal differential is always greater than the mechanical differential and depends on three factors:

- 1) the flow velocity of the medium,
- 2) the temperature change rate of the medium, and
- 3) the heat transmission to the sensor

Differentials

The mechanical differential is the differential that is set by the differential spindle in the thermostat. The thermal differential (operating differential) is the differential the system operates on.

Thermostat function

Contacts 1-4 make while contacts 1-2 break when the temperature rises above the scale setting. The contacts changeover to their initial position when the temperature falls to the scale setting minus the differential. See fig. 6.

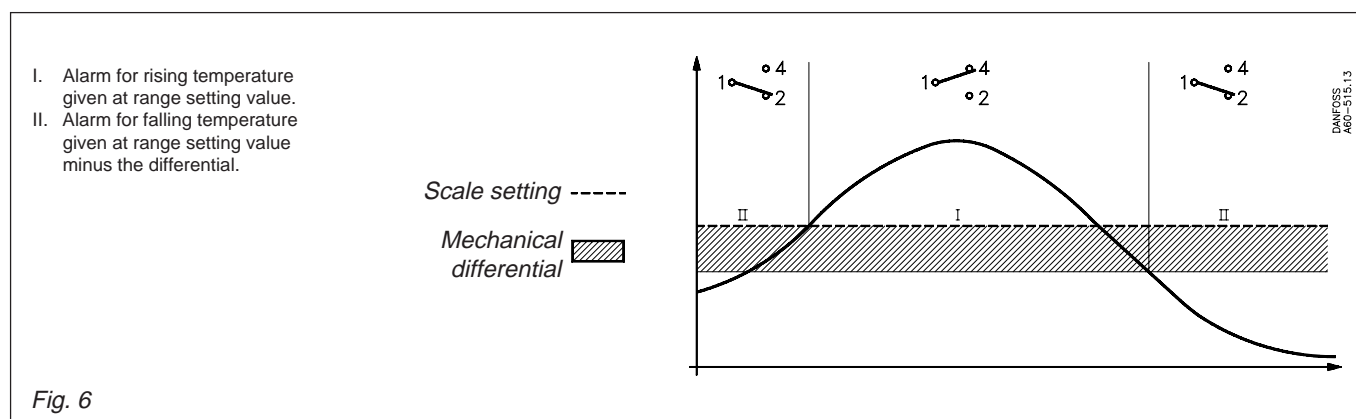

Danfoss can accept no responsibility for possible errors in catalogues, brochures and other printed material. Danfoss reserves the right to alter its products without notice. This also applies to products already on order provided that such alterations can be made without subsequential changes being necessary in specifications already agreed. All trademarks in this material are property of the respective companies. Danfoss and the Danfoss logotype are trademarks of Danfoss A/S. All rights reserved.