

SHANGHAI JIANGNAN CHANGXING HEAVY INDUSTRY CO., LTD.

Hull No. : H2431/2432/2433

5100TEU CONTAINER VESSEL

GROUP STARTER PANEL, POWER DIST.BOX AND INDIVIDUAL STARTERS

DESIGNED BY		DRAWING NO.	TC06G123
COMPARED BY		REVISION	A
CHECKED BY		CLASS	GL
APPROVED BY		DATE	2007-09-27
 TERASAKI <i>Ensuring Service, Maintaining Quality</i>		TERASAKI (CHINA) ELECTRIC CO., LTD	

VOL.1

GENERAL SPECIFICATION.....	SE
ABBREVIATION.....	AB
MCCB BREAKING CAPACITY LIST.....	BC
NAMEPLATE.....	N
SPECIFICATION LIST.....	SL
COMPONENTS LISTING.....	PL
FLOWCHART.....	FC
OUTLINE VIEW.....	OV

	FLAG OF SHIP	MARSHALL/LIBERIA			REF SHEET No.
	KIND OF SHIP	5100 TEU CLASS CONTAINER VESSEL			
GENERAL	RULE AND REGULATION	<input type="checkbox"/> ABS <input type="checkbox"/> BV <input type="checkbox"/> DNV <input checked="" type="checkbox"/> GL <input type="checkbox"/> JG <input type="checkbox"/> LRS <input type="checkbox"/> CCS <input type="checkbox"/> NK SPECIAL NOTATION <input checked="" type="checkbox"/> AUT (GL)			
	STANDARD	<input type="checkbox"/> JIS <input type="checkbox"/> JEM <input checked="" type="checkbox"/> IEC PUB.92 (SYSTEM DESIGN PHILOSOPHY ONLY) <input checked="" type="checkbox"/> GB <input type="checkbox"/> EN			
	DRAWING AND DOCUMENT	LANGUAGE: <input checked="" type="checkbox"/> ENGLISH <input type="checkbox"/> CHINESE UNIT: <input checked="" type="checkbox"/> METRIC <input checked="" type="checkbox"/> SI			
	VOLTAGE RATING	MAIN	AC440V 3φ 60HZ		
		CONTROL	220V 60HZ	DC24V	
	ENCLOSURE TYPE	IP22 (1GSP, 2GSP) IP44 WITH GLAND (INDIVIDUAL STARTER) / IP23 (FOR OTHERS GSP)			
MECHANICAL CONSTRUCTION AND INSTALLATION	LOCATION	<input checked="" type="checkbox"/> INDOOR <input type="checkbox"/> ENG CONTROL ROOM <input type="checkbox"/> OUTDOOR			
	CHANNEL OR ANGLE BASE	<input checked="" type="checkbox"/> PROVIDED <input type="checkbox"/> NOT PROVIDED			
	INSTALLATION	<input checked="" type="checkbox"/> FLOOR MOUNTING AND SELF STANDING (1GSP, 2GSP, ST2) <input checked="" type="checkbox"/> WALL MOUNTING (THE OTHERS)			
	HAND RAIL	FRONT	<input checked="" type="checkbox"/> HORIZONTAL		
		REAR	<input checked="" type="checkbox"/> HORIZONTAL		
	ACCESSIBILITY	<input checked="" type="checkbox"/> FRONT AND REAR (1GSP & 2GSP) <input checked="" type="checkbox"/> FRONT ONLY (OTHERS)			
	ENCLOSURE	FRONT	<input checked="" type="checkbox"/> DOOR	SIDE	<input checked="" type="checkbox"/> FIXED PLATE
		REAR	<input checked="" type="checkbox"/> REMOVABLE COVER (1GSP & 2GSP) <input checked="" type="checkbox"/> FIXED PLATE (OTHERS)		
		BOTTOM	<input checked="" type="checkbox"/> WITH CABLE GLAND (ST1) <input checked="" type="checkbox"/> WITH CABLE COAMING (IP23) <input checked="" type="checkbox"/> OPEN (1GSP, 2GSP, ST2)		
	PARTITION PLATE	<input checked="" type="checkbox"/> PROVIDED <input type="checkbox"/> NOT PROVIDED			
PAINT COLOR	OUTSIDE (PANEL)	<input checked="" type="checkbox"/> 7. 5BG7/2	<input checked="" type="checkbox"/> ROUGH-POLISHED		
	INSIDE (PANEL)	<input type="checkbox"/> 7. 5BG7/2 <input type="checkbox"/> 2. 5BG7/2	<input checked="" type="checkbox"/> MAKER STANDARD		
ELECTRICAL CONSTRUCTION	BUS BAR	MATERIAL:	<input checked="" type="checkbox"/> COPPER		
		CONTACT SURFACE:	<input type="checkbox"/> SILVER PLATED	<input checked="" type="checkbox"/> TIN PLATED	
	BUS BAR COLOR CODING	<input checked="" type="checkbox"/> WITH COLOR LABEL AC { PHASE (R) : <input type="checkbox"/> RED <input checked="" type="checkbox"/> GREEN PHASE (S) : <input type="checkbox"/> WHITE <input checked="" type="checkbox"/> YELLOW PHASE (T) : <input type="checkbox"/> BLUE <input checked="" type="checkbox"/> BROWN DC { POLE (P) <input checked="" type="checkbox"/> RED POLE (N) <input checked="" type="checkbox"/> BLUE			
	BUS BAR PHASE ARRANGEMENT	VIEWING FROM FRONT	LEFT	TOP	FRONT
		PHASE (R) (U) POLE (P)	↓	↓	↓
	PHASE (S) (V) POLE (N)	RIGHT	BOTTOM	REAR	
BUS DUCT	<input type="checkbox"/> PROVIDED <input type="checkbox"/> AIR INSULATION <input type="checkbox"/> INSULATION	<input checked="" type="checkbox"/> NOT PROVIDED			
CABLE ENTRANCE	<input type="checkbox"/> TOP <input checked="" type="checkbox"/> WITH CABLE GLAND (ST1)				
	<input type="checkbox"/> REAR UPPER <input checked="" type="checkbox"/> WITH CABLE COAMING (IP23)				
	<input checked="" type="checkbox"/> BOTTOM <input checked="" type="checkbox"/> OPEN (1GSP, 2GSP, ST2)				

INTERNAL WIRING MATERIAL	TYPE		600V CBYJR (85°C)	250V CBYJR (75°C)	REF SHEET No.
	CIRCUIT		<input checked="" type="checkbox"/> MIN 2.5mm		
	POWER CIRCUIT			<input checked="" type="checkbox"/> MIN 0.5mm	
TERMINAL LUG FOR MATERIAL	<input type="checkbox"/> PROVIDED <input checked="" type="checkbox"/> NOT PROVIDED				
CIRCUIT BREAKER	REFER TO BREAKING CAPACITY LIST BC1				
FUSE (CONTROL CIRCUIT)	REFER TO BREAKING CAPACITY LIST BC2				
METER	<input type="checkbox"/> SHANGHAI YITAI <input checked="" type="checkbox"/> 72 × 72 90° SCALE 1.5 CLASS BEZEL COLOR <input checked="" type="checkbox"/> BLACK <input checked="" type="checkbox"/> DEIF <input type="checkbox"/> 110 × 110 CIRCULAR SCALE <input type="checkbox"/> OTHER				
INSULATION RESISTANCE METER	<input type="checkbox"/> PROVIDED <input checked="" type="checkbox"/> NOT PROVIDED BEZEL COLOR <input type="checkbox"/> BLACK <input type="checkbox"/> 72 × 72 90° SCALE 1.5 CLASS <input type="checkbox"/> 96 × 96 90° SCALE 1.5 CLASS				
RUNNING HOUR METER	<input checked="" type="checkbox"/> PROVIDED <input type="checkbox"/> WITHOUT RESET BEZEL COLOR <input checked="" type="checkbox"/> BLACK <input type="checkbox"/> NOT PROVIDED <input type="checkbox"/> WITH RESET				
WATTHOUR METER	<input type="checkbox"/> PROVIDED <input checked="" type="checkbox"/> NOT PROVIDED BEZEL COLOR <input type="checkbox"/> BLACK				
MAIN CONTROL SWITCH	<input type="checkbox"/> K&N <input checked="" type="checkbox"/> OTHER				
INDICATING LAMP BULB	<input type="checkbox"/> E-12 28V 2W <input checked="" type="checkbox"/> MAKER STANDARD				
NAMEPLATE	MATERIAL: <input checked="" type="checkbox"/> ACRYLIC LANGUAGE: <input checked="" type="checkbox"/> ENGLISH <input type="checkbox"/> ENGLISH & CHINESE TYPE: <input type="checkbox"/> ENGRAVED <input checked="" type="checkbox"/> REVERSE ENGRAVED BACKGROUND: <input checked="" type="checkbox"/> WHITE LETTERING: <input checked="" type="checkbox"/> BLACK (GENERAL) <input checked="" type="checkbox"/> RED (WARNING)				
SPARE PARTS	<input checked="" type="checkbox"/> SUPPLIED <input type="checkbox"/> NOT SUPPLIED <input checked="" type="checkbox"/> CLASSIFICATION <input checked="" type="checkbox"/> WITH STEEL BOX <input type="checkbox"/> WITHOUT STEEL BOX <input checked="" type="checkbox"/> TERASAKI (CHINA) STANDARD BOX COLOR: <input checked="" type="checkbox"/> THE SAME AS MSB				
OTHERS					

MOLDED CASE CIRCUIT BREAKERS (MANUFACTURER:TERASAKI)

GL

TYPE	MAXIMUM CURRENT RATING	AC 500V		AC 250V		AC 125V		DC 250V	USED	
		RATED BREAKING CURRENT(kA) Sym.RMS	RATED MAKING CURRENT(kA) Asym.Peak	RATED BREAKING CURRENT(kA) Sym.RMS	RATED MAKING CURRENT(kA) Asym.Peak	RATED BREAKING CURRENT(kA) Sym.RMS	RATED MAKING CURRENT (kA) Asym.Peak	RATED BREAKING CURRENT (kA)		
XE	XE100NS	100	10	18.5	25	52.5	42*2	95.6*2	7.5	○
XS	XS50NB	50	107	18.5	25	52.5	42*2	95.6*2	7.5	
	XS100NB	100	25	52.5	50	105			15	
	XS225NS	225	25	52.5	50	105			15	
	XS400CS	400	30	63	50	105				
	XS400NS	400	42	88.2	85	187				
	XS400NE	400	42	88.2	85	187				
	XS600CS	600	30	63	50	105				
	XS600NS	600	50	105	85	187				
	XS600NE	600	50	105	85	187				
	XS800CS	800	30	63	50	105				
	XS800NS	800	50	105	85	187				
	XS800NE	800	50	105	85	187				
	XS1200NE	1200	65	143	100	220				
	XS1600NE	1600	85	187						
XS2000NE	2000	85	187							
XH	XH50NS	50	42	88.2	85	187				
	XH100NS	100	42	88.2	85	187				○
	XH225NS	225	42	88.2	85	187				○
	XH225NE	225	42	88.2	85	187				
	XH800PS	800	85	187						
TL	TL-100F	100	120	288						
	TL-225F	225	120	288				40		○
	TL-400E	400	120	288				40		○
	TL-600NE	600	125	298				40		
	TL-800NE	800	125	298						
	TL-100C	100	180	415						○
	TL-225B	225	180	415						○
	TL-400	400	180	415						
	TL-600	600	180	415						○
	TL-800	800	180	415						
	TL-1000NE	1000	125	298						
TL-1200NE	1200	125	298							
TB	TB-5D	10			2.5*3	4.1*3	43.5*1	101.6*1		
	TB-5P	15-50			5*3	8*3	43.5*1	101.6*1		

NOTE: ○ USED

*1---AT AC 125V

①---WITH INSTANTANEOUS TRIP

*2---AT AC 450V

②---WITHOUT INSTANTANEOUS TRIP

*3---AT AC 240V

FUSES

GL

MANUFACTURER	TYPE	RATED CURRENT (A)	RATED VOLTAGE (V)	RATED BREAKING CURRENT (KA)		USED
				AC (KA)	DC (KA)	
LEGRAND	HRC(10x38)	Up to 25	500	100		○

○.....USED

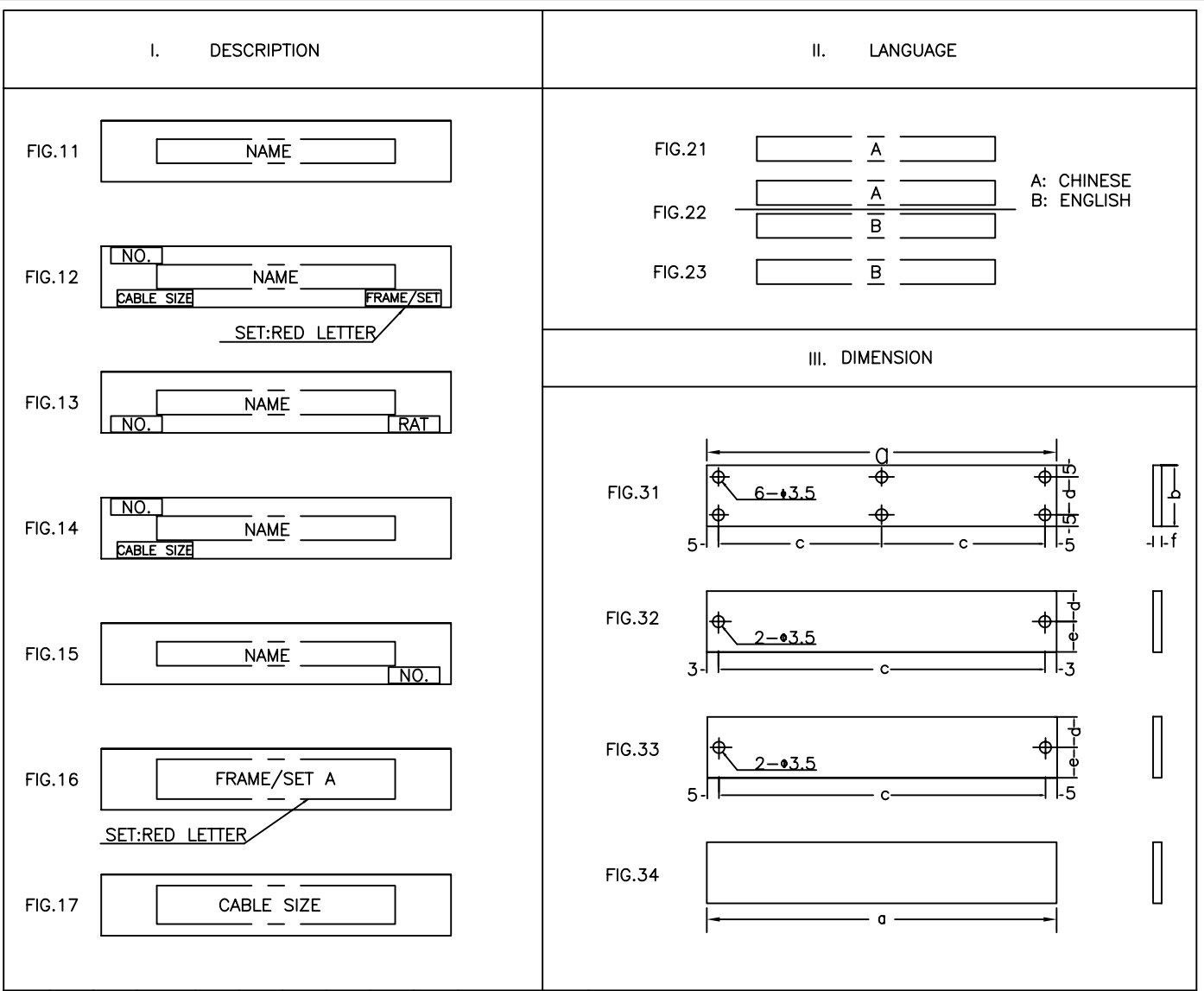

I	II	III	TYPE	a	b	c	d	e	f	REMARKS
FIG.	FIG.	FIG.								
11		31	U1	315	63	152.5	5.3	-	3	
11	23	31	U2	200	40	95	30	-	2	
11	21	33	U5S	63	25	53	12.5	12.5	2	
11		33	U6	63	16	53	8	8	2	
11		34	U7	50	12.5	-	-	-	2	
11		33	U7S	50	12.5	40	6.25	6.25	2	
11		33	U9	100	40	90	20	20	2	
14	23	33	U10	100	25	90	12.5	12.5	2	
12		32	U13	40	25	34	12.5	12.5	2	
13		34	U14	63	12.5	-	-	-	2	
12		33	U15	90	50	80	25	25	2	
14	23	33	U16	90	35	80	17.5	17.5	2	
12		33	U17	90	70	80	52.5	17.5	2	
16		34	U51	25	8	-	-	-	1	
17		34	U52	25	8	-	-	-	1	
12		33	U53	80	40	70	20	20	2	
11		33	U54	63	40	53	20	20	2	
11		33	U55	66	12.5	56.	6.25	6.25	2	
11		33	U56	100	50	90	25	25	2	
12		33	C80	80	25	70	12.5	12.5	2	
15		34	LN13	64.8	31.3	-	-	-	1	
15		34	LN12	46	20	-	-	-	1	

NOTE:
 GENERAL PLATE
 MATERIAL --- ACRYLIC
 LETTER--- BLACK(REVERSE ENGRAVED)
 GROUND ---- WHITE

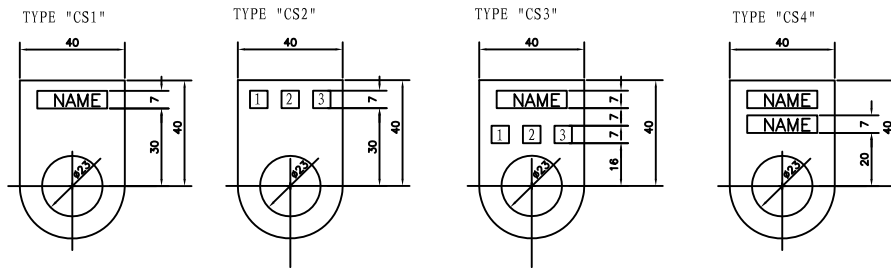

NOTE

MATERIAL : ACRYLIC
 LETTER: BLACK (REVERSE ENGRAVED)
 GROUND: WHITE

NAMEPLATE		SYMBOL	NAME			PARTS TYPE	NP NO.
TYPE	QT.		NAME	1	2		
CS1	30	WL	POWER	—	—	—	YW1P-1BEM45 PW
CS1	4	WL	AC440V POWER	—	—	—	YW1P-1BEM45 PW
CS1	34	WL1-8	POWER	—	—	—	YW1P-1BEM45 PW
CS1	28	GL	RUNNING	—	—	—	YW1P-1BEM45 G
CS1	3	GL+	SUPPLY RUNNING	—	—	—	YW1P-1BEM45 G
CS1	3	GL-	EXHAUST RUNNING	—	—	—	YW1P-1BEM45 G
CS1	34	GL1-8	RUNNING	—	—	—	YW1P-1BEM45 G
CS1	31	RL	TRIP	—	—	—	YW1P-1BEM45 R
CS1	34	RL1-8	TRIP	—	—	—	YW1P-1BEM45 R
CS1	12	SL	STANDBY	—	—	—	YW1P-1EQ0Y +LS-3
CS1	28	ST	START	—	—	—	YW1B-M1E10 G
CS1	3	ST+	SUPPLY START	—	—	—	YW1B-M1E10 G
CS1	3	ST-	EXHAUST START	—	—	—	YW1B-M1E10 G
CS1	34	ST1-8	START	—	—	—	YW1B-M1E10 G
CS1	30	SP	STOP	—	—	—	YW1B-M1E01 R
CS1	12	SP	STOP/RESET	—	—	—	YW1B-M1E01 R
CS1	34	SP1-8	STOP	—	—	—	YW1B-M1E01 R
CS3	12	SW	MODE SELECTOR	MANUAL	—	AUTO	YW1S-2E10
CS3	1	SW1	MODE SELECTOR	MANUAL	—	AUTO	YW1S-2E11
CS3	1	SW1	MODE SELECTOR	NO. 1 CYL. AUTO NO. 2 CYL. MANU	NO. 1 CYL. MANU NO. 2 CYL. MANU	NO. 1 CYL. MANU NO. 2 CYL. AUTO	YW1S-3E20
CS3	1	SW1	MODE SELECTOR	NO. 1 F. W. AUTO NO. 2 F. W. MANU	NO. 1 F. W. MANU NO. 2 F. W. MANU	NO. 1 F. W. MANU NO. 2 F. W. AUTO	YW1S-3E20
CS3	1	SW2	MODE SELECTOR	H. F. O. SETT. TK.	—	LOW SULFUR SETT. TK.	YW1S-2E11
CS3	19	SHS	SPACE HEATER	OFF	—	ON	ASLW29920EA +LSED-M3A
CS3	12	SHS1-8	SPACE HEATER	OFF	—	ON	ASLW29920EA +LSED-M3A
CS3	5	BY-PASS	MODE SELECTOR	NORMAL	—	BY-PASS	YW1S-2E10
CS1	1	RS	RESET				YW1L-MF2E10Q4R
CS3	6	SW3	MODE SELECTOR	LOCAL	—	REMOTE	YW1S-2E21

COLOR TIE
DIMENSION

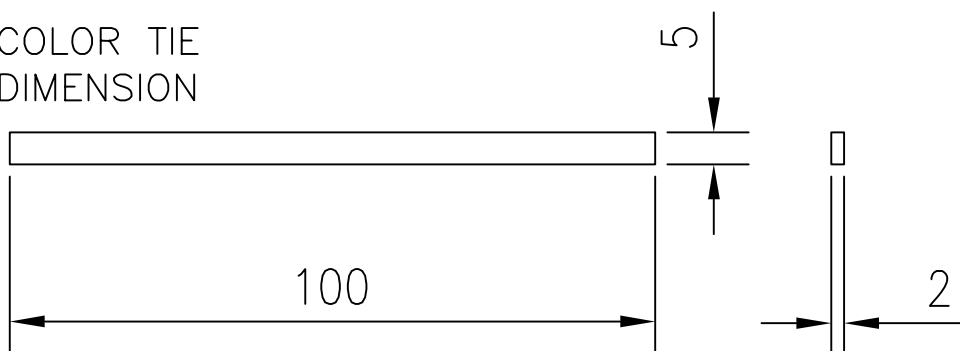

CODE	COLOR	QT	NOTE
ES1	RED	3	
ES2	ORANGE	10	
ES	BLACK	4	
SQ	GREEN	13	

INSTALATION MODE:

NAMEPLATE
COLOR TIE

NOTE:

- *ES1--EMER.STOP FOR E/R FANS
- *ES2--EMER.STOP FOR E/R OIL PUMPS
- *SQ--SEQUENTIAL START

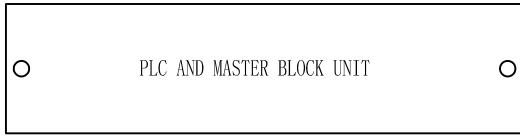

NP TYPE : U10
 NP No. : NP
 QT: 1
 USED FOR PLC UNIT

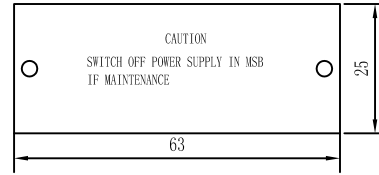

LETTER: RED
 NP TYPE: U5S

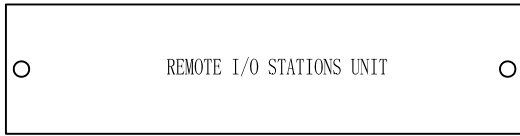

NP TYPE : U10
 NP No. : NP1
 QT: 1
 USED FOR PLC REMOTE UNIT

NP No. : NP10
 QT: 6
 USE FOR: NO. 1/NO. 2 FIRE BILGE & G. S. PUMP
 LOCAL CONTROL PB OF NO. 1/NO. 2 FIRE BILGE & G. S. PUMP
 FIRE STATION PB OF NO. 1/NO. 2 FIRE BILGE & G. S. PUMP

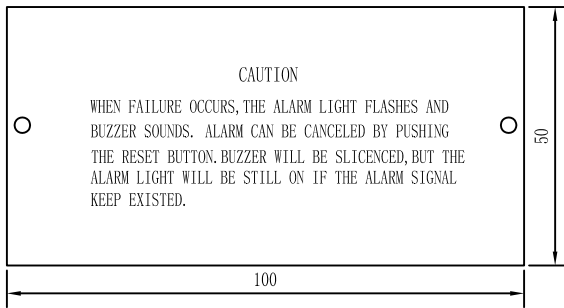

NP TYPE : U56
 NP No. : NP2
 QT: 1
 USED FOR ALARM RESET

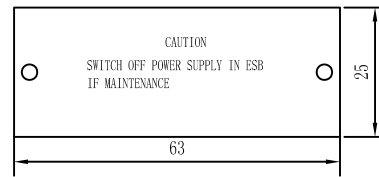

LETTER: RED
 NP TYPE: U5S

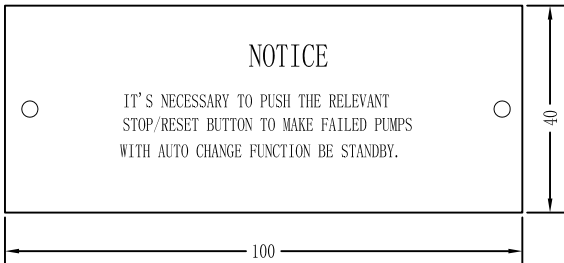

NP TYPE : U9
 NP No. : NP4
 QT: 12
 USEd FOR : 1GSP2, 1GSP3, 1GSP4, 1GSP6, 1GSP8, 1GSP13
 2GSP2, 2GSP3, 2GSP4, 2GSP6, 2GSP7, 2GSP13
 LETTER : RED

NP No. : NP11
 QT: 2
 USE FOR: EMERG. FIRE PUMP
 FIRE STATION PB OF EMERG. FIRE PUMP

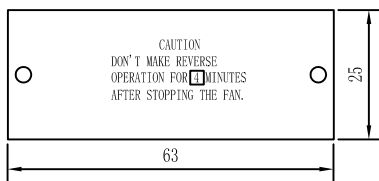

NP TYPE: U5S
 NP No. : NP3
 QT: 3
 USE FOR: No. 3 E/R VENT FAN (REVERSIBLE) (1GSP5)
 No. 4 E/R VENT FAN (REVERSIBLE) (2GSP8, ST1)

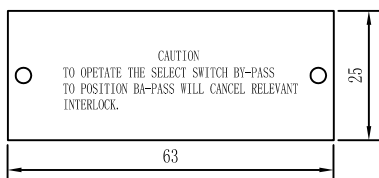

NP TYPE: U5S
 NP No. : NP5
 QT: 3
 USE FOR: NO. 1 M/E JACKET C. F. W. PUMP (1GSP3)
 NO. 2 M/E JACKET C. F. W. PUMP (2GSP3)
 M/E JACKET C. F. W. PUMP (2GSP5)

			MOTOR		ISOLATING MEANS			CABLE		CONTROL						INSTRUMENTS & OTHER				REFER TO
			RATE AC450V 60Hz		TYPE RATED CURRENT	CONNE- CTION	ACCESSORY	LINE	LOAD	START METHOD	CONTROL METHOD	U V FEATURE SEQUENT IAL START DELAY TIME (SET)	REMOTE CONTROL	EMERG STOP	SPACE HEATER	AMMETER		RUNNING HOUR METER	TRANSFO -RMER TYPE	DIAGRAM (PAGE)
NP TYPE	CIRCUIT NO.	CIRCUIT NAME	KW	A												CT TYPE BH-0.66	A TYPE			
U2	100,200, 300	NO.1 GROUP STARTER PANEL																		
U10	1GSP1	NO.1 E/R VENT.FAN	104	173	TL400 250A	FPM	SHT	BUSBAR	3x95	DOL	NA	UVR 15S		ES1	SHIPYARD SUPPLY	250/5	0-250-1250	HK3031	JBK3 30VA	D1GSP1
U10	1GSP2	NO.1 L.T. COOLING F.W. PUMP	128	200	TL400 250A	FPM		BUSBAR	3x120	DOL	ACO-NV/PS	UVR 10S	M/S		SHIPYARD SUPPLY	300/5	0-300-1500	HK3031	JBK3 30VA	D1GSP2
U10	1GSP3	NO.1 M/E JACKET C.F.W. PUMP	52.4	83	TL225B 125A	FPM		BUSBAR	3x50	DOL	ACO-NV/PS	UVR 10S	M/S		SHIPYARD SUPPLY	150/5	0-150-750	HK3031	JBK3 30VA	D1GSP3
U10	1GSP4	NO.1 COOLING S.W. PUMP	104	164	TL225B 200A	FPM		BUSBAR	3x95	DOL	ACO-NV/PS	UVR 20S	M/S	ESS	SHIPYARD SUPPLY	250/5	0-250-1250	HK3031	JBK3 30VA	D1GSP4
U10	1GSP5	NO.3 E/R VENT.FAN (SUPPLY& EXHAUST)	86	143.8	TL225B 225A	FPM	SHT	BUSBAR	3x95	DOL, REV	NA	UVR 60S	M/S	ES1	SHIPYARD SUPPLY	200/5	0-200-1000	HK3031	JBK3 50VA	D1GSP5
U10	1GSP6	NO.3 COOLING S.W. PUMP	104	164	TL225B 200A	FPM		BUSBAR	3x95	DOL	ACO-NV/PS	UVR 20S	M/S	ESS	SHIPYARD SUPPLY	250/5	0-250-1250	HK3031	JBK3 30VA	D1GSP6
U10	1GSP7	H.F.O. TRANSFER PUMP	17.5	31.8	TL100C 40A	PC	SHT	BUSBAR	3x10	DOL	ASS	UVP	M/S, EPB1 EPB2	ES2		40/5	0-40-200	HK3031	JBK3 30VA	D1GSP7
U10	1GSP8	NO.1 MAIN L.O. PUMP	291	433	TL600 600A	PM	SHT	BUSBAR	4(3x70)	Y-D	ACO-NV/PS	UVR 5S	M/S	ES2	SHIPYARD SUPPLY	600/5	0-600-3000	HK3031	JBK3 30VA	D1GSP8
U10	1GSP9	NO.1 BALLAST PUMP	87.3	137	TL225B 175A	FPM	SHT	BUSBAR	3x95	DOL	SP	UVP	M/S, VALVE CABINET	ES ESS	SHIPYARD SUPPLY	200/5	0-200-1000	HK3031	JBK3 100VA	D1GSP9
U10	1GSP10	NO.1 FIRE BILGE & G.S. PUMP	128	200	TL400 250A	FPM	SHT	BUSBAR	2(3x50)	DOL	SP	UVP	M/S, FIRE STATION, WHC, VALVE CABINET	ES ESS	SHIPYARD SUPPLY	300/5	0-300-1500	HK3031	JBK3 100VA	D1GSP10
U10	1GSP11	CYL. L.O. TRANSFER PUMP	1.3	2.51	TL100C 15A	PC	SHT	BUSBAR	3x1.5	DOL	ASS	UVP	M/S	ES2			0-5-25	HK3031	JBK3 30VA	D1GSP11
U10	1GSP12	DAILY BILGE PUMP	3.5	6.98	TL100C 15A	PC		BUSBAR	3x1.5	DOL	NA	UVP	EPB1, EPB2			15/5	0-15-75	HK3031	JBK3 30VA	D1GSP12
U10	1GSP13	NO.1 STERN TUBE LUB. OIL PUMP	1.3	2.51	TL100C 15A	PC	SHT	BUSBAR	3x1.5	DOL	ACO-NV/PS	UVP	M/S	ES2	SHIPYARD SUPPLY		0-5-25	HK3031	JBK3 30VA	D1GSP13
U10	1GSP14	L.O. TRANSFER PUMP	10.7	19.8	TL100C 30A	PC	SHT	BUSBAR	3x4	DOL	NA	UVP	M/S	ES2		30/5	0-30-150	HK3031	JBK3 30VA	D1GSP14
U10	1GSP15	AIR COOLER CHEMICAL CLEANING PUMP	1.8	3.4	TL100C 15A	PC		BUSBAR	3x1.5	DOL	NA	UVP	M/S				0-5-25	HK3031	JBK3 30VA	D1GSP15

NOTE: SQ - - SEQUENTIAL STARTING
SP - -SELF-PRIMNG UNIT
ACO - - AUTO CHANGE-OVER
SHT - - SHUNT TRIP
UVP - - LOW VOLTAGE PROTECTION
UVR - - LOW VOLTAGE RELEASE
ASS - - AUTO START AND STOP

			MOTOR		ISOLATING MEANS			CABLE		CONTROL						INSTRUMENTS & OTHER				REFER TO
NP TYPE	CIRCUIT NO.	CIRCUIT NAME	RATE AC450V 60Hz		TYPE RATED CURRENT	CONNECTION	ACCESSORY	LINE	LOAD	START METHOD	CONTROL METHOD	UV FEATURE SEQUENTIAL START DELAY TIME (SET)	REMOTE CONTROL	EMERG STOP	SPACE HEATER	AMMETER		RUNNING HOUR METER	TRANSFORMER TYPE	DIAGRAM (PAGE)
			KW	A												CT TYPE BH-0.66	A TYPE			
U2	400,500,600	NO.2 GROUP STARTER PANEL																		
U10	2GSP1	NO.2 E/R VENT.FAN	104	173	TL400 250A	FPM	SHT	BUSBAR	3x95	DOL	NA	UVR 20S		ES1	SHIPYARD SUPPLY	250/5	0-250-1250	HK3031	JBK3 30VA	D2GSP1
U10	2GSP2	NO.2 COOLING S.W. PUMP	104	164	TL225B 200A	FPM		BUSBAR	3x95	DOL	ACO-NV/PS	UVR 20S	M/S	ESS	SHIPYARD SUPPLY	250/5	0-250-1250	HK3031	JBK3 30VA	D2GSP2
U10	2GSP3	NO.2 M/E JACKET C.F.W. PUMP	52.4	83	TL225B 125A	FPM		BUSBAR	3x50	DOL	ACO-NV/PS	UVR 10S	M/S		SHIPYARD SUPPLY	150/5	0-150-750	HK3031	JBK3 30VA	D2GSP3
U10	2GSP4	NO.2 L.T. COOLING F.W. PUMP	128	200	TL400 250A	FPM		BUSBAR	3x120	DOL	ACO-NV/PS	UVR 10S	M/S		SHIPYARD SUPPLY	300/5	0-300-1500	HK3031	JBK3 30VA	D2GSP4
U10	2GSP5	M/E JACKET W. HEATING PUMP	12.8	21.7	TL100C 30A	PC		BUSBAR	3x1.5	DOL	NA	UVP	M/S			30/5	0-30-150	HK3031	JBK3 30VA	D2GSP5
U10	2GSP6	NO.3 L.T. COOLING F.W. PUMP	128	200	TL400 250A	FPM		BUSBAR	3x120	DOL	ACO-NV/PS	UVR 10S	M/S		SHIPYARD SUPPLY	300/5	0-300-1500	HK3031	JBK3 30VA	D2GSP6
U10	2GSP7	NO.2 MAIN L.O. PUMP	291	433	TL600 600A	PM	SHT	BUSBAR	4(3x70)	Y-D	ACO-NV/PS	UVR 5S	M/S	ES2	SHIPYARD SUPPLY	600/5	0-600-3000	HK3031	JBK3 30VA	D2GSP7
U10	2GSP8	NO.4 E/R VENT.FAN															0-200-1000	HK3031		D2GSP8
U10	2GSP9	SLUDGE PUMP	4.7	7.7	TL100C 15A	PC	SHT	BUSBAR	3x1.5	DOL	NA	UVP	M/S, EPB1, EPB2	ES2		15/5	0-15-75	HK3031	JBK3 30VA	D2GSP9
U10	2GSP10	NO.2 BALLAST PUMP	87.3	137	TL225B 175A	FPM	SHT	BUSBAR	3x95	DOL	SP	UVP	M/S, VALVE CABINET	ES ESS	SHIPYARD SUPPLY	200/5	0-200-1000	HK3031	JBK3 100VA	D2GSP10
U10	2GSP11	NO.2 FIRE BILGE & G.S. PUMP	128	200	TL400 250A	FPM	SHT	BUSBAR	2(3x50)	DOL	SP	UVP	M/S, FIRE STATION, WHC	ES ESS	SHIPYARD SUPPLY	300/5	0-300-1500	HK3031	JBK3 100VA	D2GSP11
U10	2GSP12	SPARE	1.3	2.51	TL100C 15A	PC	SHT	BUSBAR	3x1.5	DOL	ASS	UVP	M/S				0-5-25	HK3031	JBK3 30VA	D2GSP12
U10	2GSP13	NO.2 STERN TUBE LUB. OIL PUMP	1.3	2.51	TL100C 15A	PC	SHT	BUSBAR	3x1.5	DOL	ACO-NV/PS	UVP	M/S	ES2			0-5-25	HK3031	JBK3 30VA	D2GSP13
U10	2GSP14	D.O. TRANSFER PUMP	21.5	36.5	TL100C 50A	PC	SHT	BUSBAR	3x10	DOL	NA	UVP	M/S, EPB1, EPB2	ES2		50/5	0-50-250	HK3031	JBK3 30VA	D2GSP14
U10	2GSP15	STEERING GEAR ROOM SUPPLY FAN																		D2GSP15

NOTE: SQ -- SEQUENTIAL STARTING
SP -- SELF-PRIMING UNIT
ACO -- AUTO CHANGE-OVER
SHT -- SHUNT TRIP
UVP -- LOW VOLTAGE PROTECTION
UVR -- LOW VOLTAGE RELEASE
ASS -- AUTO START AND STOP

			MOTOR		ISOLATING MEANS			CABLE		CONTROL						INSTRUMENTS & OTHER			REFER TO	
			RATE AC450V 60Hz		TYPE RATED CURRENT	CONNE- CTION	ACCESSORY	LINE	LOAD	START METHOD	CONTROL METHOD	U V FEATURE SEQUENT IAL START DELAY TIME (SET)	REMOTE CONTROL	EMERG STOP	SPACE HEATER	AMMETER		RUNNING HOUR METER	TRANSFO -RMER TYPE	DIAGRAM (PAGE)
NP TYPE	CIRCUIT NO.	CIRCUIT NAME	KW	A												CT TYPE BH-0.66	A TYPE			
U2	1000	NO. 405 POWER DIST. BOX																		OV405
U10	405ST1 (01)	NO.1 FRESH WATER PUMP	6.4	11.1	XH100NS 15A	PM		3x1.5	DOL	ASS	UVP			SHIPYARD SUPPLY			HK3031	JBK3 200VA, 30VA	405ST1 (01)	
U10	405ST2 (02)	NO.2 FRESH WATER PUMP	6.4	11.1	XH100NS 15A	PM		3x1.5	DOL	ASS	UVP			SHIPYARD SUPPLY			HK3031	JBK3 200VA	405ST2 (02)	
U10	405ST3 (03)	NO.1 A/C COOLING FW BOOSTER PUMP	6.6	11.9	XH100NS 15A	PM		3x1.5	DOL	NA	UVP	M/S		SHIPYARD SUPPLY			HK3031	JBK3 200VA	405ST3 (03)	
U10	405ST4 (04)	NO.2 A/C COOLING FW BOOSTER PUMP	6.6	11.9	XH100NS 15A	PM		3x1.5	DOL	NA	UVP	M/S		SHIPYARD SUPPLY			HK3031	JBK3 200VA	405ST4 (04)	
U10	405ST5 (05)	HOT WATER CIRC. PUMP	0.87	2.17	XH100NS 15A	PM		3x1.5	DOL	NA	UVP							JBK3 30VA	405ST5 (05)	
U10	(06)	SPARE			XH100NS 15A	PM													(06)	
U10	(07)	SEWAGE TREAT. PLANT CONTROL BOX	4.1		XH100NS 15A	PM		3x1.5											(07)	
U10	(08)	F.W. GENERATOR CONTROL PANEL	22.15		XH100NS 40A	PM		3x10											(08)	
U10	(09)	NO.2 IMPRESSED CURRENT CATHODIC PROTECTION SYSTEM CONT. BOX	9.6		XH100NS 20A	PM		3x2.5											(09)	
U10	(10)	NO.1 & NO.2 SEWAGE COLLECTING TANK	3.6x2		XH100NS 20A	PM		3x2.5											(10)	
U10	(11)	SPARE			XH100NS 40A	PM													(11)	
U10	(12)	SPARE			XH100NS 15A	PM													(12)	
U2	1001	NO. 409 POWER DIST. BOX																		OV409
U10	409ST1 (01)	SANITARY EXH. FAN FOR ACC.	4	7.1	XE100NS 15A	PM		3x1.5	DOL	NA	UVP							JBK3 30VA	409ST1 (01)	
U10	409ST2 (02)	GALLEY SUPPLY FAN	0.75	1.75	XE100NS 15A	PM		3x1.5	DOL	NA	UVP	M/S	ES6					JBK3 30VA	409ST2 (02)	
U10	409ST3 (03)	GALLEY EXH. FAN	1.5	3.2	XE100NS 15A	PM		3x1.5	DOL	NA	UVP	M/S	ES6					JBK3 30VA	409ST3 (03)	
U10	409ST4 (04)	BATTERY ROOM EXH. FAN	0.55	1.33	XE100NS 15A	PM		3x1.5	DOL	NA	UVP			SHIPYARD SUPPLY				JBK3 200VA	409ST4 (04)	
U10	(05)	SPARE			XE100NS 15A	PM													(05)	
U10	409ST6 (06)	STEERING GEAR ROOM SUPPLY FAN	4	7.1	XE100NS 15A	PM		3x1.5	DOL	NA	UVP	M/S,MSB, SHIP'S OFFICE		SHIPYARD SUPPLY				JBK3 200VA	409ST6 (06)	
U10	409ST7 (07)	CO2 ROOM EXH. FAN	2.2	4.4	XE100NS 15A	PM		3x1.5	DOL	NA	UVP	M/S		SHIPYARD SUPPLY				JBK3 200VA	409ST7 (07)	

NOTE : UVP -- LOW VOLTAGE PROTECTION

ASS -- AUTO START AND STOP

			MOTOR		ISOLATING MEANS			CABLE		CONTROL						INSTRUMENTS & OTHER				REFER TO
NP TYPE	CIRCUIT NO.	CIRCUIT NAME	RATE AC450V 60Hz		TYPE RATED CURRENT	CONNECTION	ACCESSORY	LINE	LOAD	START METHOD	CONTROL METHOD	U V FEATURE SEQUENTIAL START DELAY TIME (SET)	REMOTE CONTROL	EMERG STOP	SPACE HEATER	AMMETER		RUNNING HOUR METER	TRANSFO -RMER TYPE	DIAGRAM (PAGE)
			KW	A												CT TYPE BH-0.66	A TYPE			
U10	409ST8 (08)	AIR CON.RM EXH.FAN	1.1	2.15	XE100NS 15A	PM			3x1.5						SHIPYARD SUPPLY				JBK3 200VA	409ST8 (08)
U10	(09)	AIR CODITIONER FOR GALLEY	14.2		XE100NS 30A	PM	SHT		3x6					ES6 PT1						(09)
U10	(10)	EM'CY GENERATOR RM HEATER	2		XE100NS 15A	PM	SHT		3x1.5					PT1						(10)
U10	(11)	EM'CY GENERATOR RM HEATER	2		XE100NS 15A	PM	SHT		3x1.5					PT1						(11)
U10	(12)	SPARE			XE100NS 30A	PM														(12)
U2	1002	NO. 410 POWER DIST. BOX																		OV410
U10	410ST1 (01)	ENGINEER'S WORKSHOP EXH. FAN	3	5.45	XE100NS 15A	PM			3x1.5	DOL	NA	UVP							JBK3 30VA	410ST1 (01)
U10	410ST2 (02)	WELDING SPACE EXH. FAN	0.75	1.75	XE100NS 15A	PM			3x1.5	DOL	NA	UVP							JBK3 30VA	410ST2 (02)
U10	410ST3 (03)	PURIFIER SPACE EXH. FAN	15	27.3	XE100NS 40A	PM			3x6	DOL	NA	UVP				40/5	0-40-200	HK3031	JBK3 30VA	410ST3 (03)
U10	(04)	SPARE			XE100NS 15A	PM														(04)
U10	(05)	ENGINEER 'S WORKSHOP PACKAGE CONDITONER	6.6		XE100NS 15A	PM	SHT		3x1.5					PT1						(05)
U10	(06)	SPARE			XE100NS 30A	PM														(06)
U2	1003	NO. 411 POWER DIST. BOX																		OV411
U10	411ST1 (01)	PIPE TUNNEL SUPPLY FAN	3	5.45	XE100NS 15A	PM			3x1.5	DOL	NA	UVP	M/S	ES4	SHIPYARD SUPPLY				JBK3 200VA	411ST1 (01)
U10	411ST2 (02)	BOW THRUSTER & EMRGNCY FIRE PUMP ROOM SUPPLY FAN	4	7.1	XE100NS 15A	PM			3x1.5	DOL	NA	UVP	M/S	ES4	SHIPYARD SUPPLY				JBK3 200VA	411ST2 (02)
U10	411ST3 (03)	NO.1 PASSAGEWAY SUPPLY FAN(P)	7.5	13.2	XE100NS 20A	PM			3x1.5	DOL	NA	UVP	WHC	ES4	SHIPYARD SUPPLY	20/5	0-20-100	HK3031	JBK3 200VA	411ST3 (03)
U10	411ST4 (04)	NO.2 PASSAGEWAY SUPPLY FAN(S)	7.5	13.2	XE100NS 20A	PM			3x1.5	DOL	NA	UVP	WHC	ES4	SHIPYARD SUPPLY	20/5	0-20-100	HK3031	JBK3 200VA	411ST4 (04)
U10	(05)	NO.1 IMPRESSED CURRENT CATHODIC PROTECTION SYSTEM CONT. BOX	4		XE100NS 15A	PM			3x1.5											(05)
U10	(06)	ELECTRIC WELDER SOCKET			XE100NS 30A	PM	SHT		3x6					PT1						(06)
U10	(07)	BOW THRUSTER & EMERGENCY FIRE PUMP ROOM HEATER	2		XE100NS 15A	PM	SHT							PT1						(07)
U10	(08)	BOW THRUSTER & EMERGENCY FIRE PUMP ROOM HEATER	2		XE100NS 15A	PM	SHT							PT1						(08)
U10	(09)	BOSUN STORE ROOM HEATER	5		XE100NS 15A	PM	SHT							PT1						(09)
U10	(10)	BOSUN STORE ROOM HEATER	5		XE100NS 15A	PM	SHT							PT1						(10)

NOTE: UVP -- LOW VOLTAGE PROTECTION
ASS -- AUTO START AND STOP

			MOTOR		ISOLATING MEANS			CABLE		CONTROL						INSTRUMENTS & OTHER				REFER TO
NP TYPE	CIRCUIT NO.	CIRCUIT NAME	RATE AC450V 60Hz		TYPE RATED CURRENT	CONNE- TION	ACCESSO RY	LINE	LOAD	START METHOD	CONTROL METHOD	U V FEATURE SEQUENTIAL START DELAY TIME (SET)	REMOTE CONTROL	EMERG STOP	SPACE HEATER	AMMETER		RUNNING HOUR METER	TRANSFO -RMER TYPE	DIAGRAM (PAGE)
			KW	A												CT TYPE BH-0.66	A TYPE			
U10	411ST5 (11)	PAINT ROOM EXH. FAN	0.75	1.75	XE100NS 15A	PM													JBK3 30VA	411ST5 (11)
U10	411ST6 (12)	AIR LOCK SUPPLY FAN	0.55	1.33	XE100NS 15A	PM							M/S						JBK3 30VA	411ST6 (12)
U10	(13)	SPARE			XE100NS 30A	PM														(13)
U10	(14)	SPARE			XE100NS 15A	PM														(14)
U10	411ST7 (15)	FORECASTLE CO2 EXH.FAN	0.75	1.75	XE100NS 15A	PM							M/S							411ST7 (15)
U2		NO.1 HOLD FANS GROUP STARTER PANEL																		
U10	3GSP1	NO.1 CARGO HOLD EXH. FAN (FWD)	2.2	4.07	XE100NS 15A	FC		3x1.5	DOL	NA	UVP	WHC				15/5	0-15-75		JBK3 30VA	D3GSP1
U10	3GSP2	NO.2 CARGO HOLD EXH. FAN (FWD)	7.5	13.2	XE100NS 20A	FC		3x2.5	DOL	NA	UVP	WHC				20/5	0-20-100		JBK3 30VA	D3GSP2
U10	3GSP3	NO.3 CARGO HOLD EXH. FAN (FWD)	7.5	13.2	XE100NS 20A	FC		3x2.5	DOL	NA	UVP	WHC				20/5	0-20-100		JBK3 30VA	D3GSP3
U10	3GSP4	NO.4 CARGO HOLD EXH. FAN (FWD)	7.5	13.2	XE100NS 20A	FC		3x2.5	DOL	NA	UVP	WHC				20/5	0-20-100		JBK3 30VA	D3GSP4
U10	3GSP5	NO.5 CARGO HOLD EXH. FAN (FWD)	7.5	13.2	XE100NS 20A	FC		3x2.5	DOL	NA	UVP	WHC				20/5	0-20-100		JBK3 30VA	D3GSP5
U10	3GSP6	NO.6 CARGO HOLD EXH. FAN (FWD)	4	7.7	XE100NS 15A	FC		3x1.5	DOL	NA	UVP	WHC				15/5	0-15-75		JBK3 30VA	D3GSP6
U2		NO.2 HOLD FANS GROUP STARTER PANEL																		
U10	4GSP1	NO.1 CARGO HOLD EXH. FAN (AFT)	2.2	4.07	XE100NS 15A	FC		3x1.5	DOL	NA	UVP	WHC				15/5	0-15-75		JBK3 30VA	D4GSP1
U10	4GSP2	NO.2 CARGO HOLD EXH. FAN (AFT)	7.5	13.2	XE100NS 20A	FC		3x2.5	DOL	NA	UVP	WHC				20/5	0-20-100		JBK3 30VA	D4GSP2
U10	4GSP3	NO.3 CARGO HOLD EXH. FAN (AFT)	7.5	13.2	XE100NS 20A	FC		3x2.5	DOL	NA	UVP	WHC				20/5	0-20-100		JBK3 30VA	D4GSP3
U10	4GSP4	No.4 CARGO HOLD EXH. FAN (AFT)	7.5	13.2	XE100NS 20A	FC		3x2.5	DOL	NA	UVP	WHC				20/5	0-20-100		JBK3 30VA	D4GSP4
U10	4GSP5	NO.5 CARGO HOLD EXH. FAN (AFT)	7.5	13.2	XE100NS 20A	FC		3x2.5	DOL	NA	UVP	WHC				20/5	0-20-100		JBK3 30VA	D4GSP5
U10	4GSP6	NO.6 CARGO HOLD EXH. FAN (AFT)	4	7.7	XE100NS 15A	FC		3x1.5	DOL	NA	UVP	WHC				15/5	0-15-75		JBK3 30VA	D4GSP6
		INDIVIDUAL STARTER																		
U10	ST1	NO.4 E/R VENT.FAN(SUPPLY & EXHAUST)	86	143.8	XH225NS 225A	FC		CABLE 3x95	2(3x50)	Y-D, REV	NA	UVP	MSB		SHIPYARD SUPPLY	200/5	0-200-1000	HK3031	JBK3 200VA	ST1
U10	ST2	EMERG. FIRE PUMP	52.4	82	XH225NS 125A	FC		CABLE 3x50	2(3x16)	Y-D	SP	UVP	M/S, WHC		SHIPYARD SUPPLY	150/5	0-150-750	HK3031	JBK3 50VA, 2000VA	ST2

NO. CIRCUIT	CIRCUIT NAME	SPECIFICATION AND TYPE															
		NO. 1 GROUP STARTER PANEL															
UNIT NAME	AC CONTACTORS	OVERLOAD RELAYS	CONTROL TRANSFORMER	FUSE	INDICATOR LIGHTS	PUSH-BUTTON	SELECTOR SWITCH	CONTACTOR RELAYS	RUN HOUR METER	TIMER RELAY	PLC						
MANUFACTURE	ABB (3P AC440V 60Hz)	ABB (3P)	SHANGHAI HONGQI (60Hz)	LEGRAND	IDEC	IDEC	IDEC	IDEC FUJI	LINE	CARLO GAVAZZI	MITSUBI-SHI						
D1GSP1	NO.1 E/R VENT.FAN	1	1	013302 013304 013306	1	1	1	1	1	1	1						
D1GSP2	NO.1 L.T. COOLING F.W. PUMP	1	1	5 2	1	1	1	2	1	1	1						
D1GSP3	NO.1 M/E JACKET C.F.W. PUMP	1	1	5 2	1	1	2	2	1	1	1						
D1GSP4	NO.1 COOLING S.W. PUMP	1	1	5 2	1	1	1	2	1	1	1						
D1GSP5	NO.3 E/R VENT.FAN (SUPPLY & EXHAUST)	2	1	5 2	1	2	1	3	1	2	1						
D1GSP6	NO.3 COOLING S.W. PUMP	1	1	5 2	1	1	1	2	1	1	1						
D1GSP7	H.F.O.TRANSFER PUMP	1	1	3 2	1	1	2	1	1	1	1						
D1GSP8	NO.1 MAIN L.O. PUMP	1	1	7 2	1	1	1	2	1	1	1						
D1GSP9	NO.1 BALLAST PUMP	1	1	5 2	1	1	1	2	1	1	1						
D1GSP10	NO.1 FIRE BILGE & G.S. PUMP	1	1	5 2	1	1	1	2	1	1	1						
D1GSP11	CYL. L.O. TRANSFER PUMP	1	1	3 2	1	1	1	1	1	1	1						
D1GSP12	DAILY BILGE PUMP	1	1	3 2	1	1	1	1	1	1	1						
D1GSP13	NO.1 STERN TUBE LUB.OIL PUMP	1	1	5 2	1	1	1	2	1	1	1						
D1GSP14	L.O. TRANSFER PUMP	1	1	3 2	1	1	1	1	1	1	1						
D1GSP15	AIR COOLER CHEMICAL CLEANING PUMP	1	1	5 2	1	1	1	1	1	1	1						
	PLC UNIT 1			2	1	1		22			1						

A B C D E F G H I



NO.1 GROUP STARTER PANEL COMPONENTS LIST

PL1 1-15

NO. CIRCUIT	CIRCUIT NAME	SPECIFICATION AND TYPE															
		NO. 2 GROUP STARTER PANEL															
UNIT NAME	AC CONTACTORS	OVERLOAD RELAYS	CONTROL TRANSFORMER	FUSE	INDICATOR LIGHTS	PUSH-BUTTON	SELECTOR SWITCH	CONTACTOR RELAYS	RUN HOUR METER	TIMER RELAY	PLC						
MANUFACTURE	ABB (3P AC440V 60Hz)	ABB (3P)	SHANGHAI HONGGOL (60Hz)	LEGRAND	IDEC	IDEC	IDEC	IDEC FUJI	LINE	CARLO GAVAZZI	MITSUBI-SHI						
D2GSP1	NO.2 E/R VENT.FAN			013302 013304 013306	1 1 1	1 1 1	1 1 1	1 1 1	1								
D2GSP2	NO.2 COOLING S.W. PUMP			5 2	1 1 1	1 1 1	1 1 1	2 1 1	1								
D2GSP3	NO.2 M/E JACKET C.F.W. PUMP	1		5 2	1 1 1	1 1 1	2 1 1	2 1 1	1								
D2GSP4	NO.2 L.T. COOLING F.W. PUMP			5 2	1 1 1	1 1 1	1 1 1	2 1 1	1								
D2GSP5	M/E JACKET W. HEATING PUMP	1		3 2	1 1 1	1 1 1	1 1 1	1 1 1	1								
D2GSP6	NO.3 L.T. COOLING F.W. PUMP			5 2	1 1 1	1 1 1	1 1 1	2 1 1	1								
D2GSP7	NO.2 MAIN L.O. PUMP			7 2	1 1 1	1 1 1	1 1 1	2 2 2	1	1							
D2GSP8	NO.4 E/R VENT.FAN (SUPPLY & EXHAUST)				2	2	2		1								
D2GSP9	SLUDGE PUMP	1		3 2	1 1 1	1 1 1	1 1 1	1 1 1	1								
D2GSP10	NO.2 BALLAST PUMP		1	5 2	1 1 1	1 1 1	1 1 1	2 1 1	1	1							
D2GSP11	NO.2 FIRE BILGE & G.S. PUMP			5 2	1 1 1	1 1 1	1 1 1	2 1 1	1	1							
D2GSP12	SPARE	1	1	3 2	1 1 1	1 1 1	1 1 1	1 1 1	1								
D2GSP13	NO.2 STERN TUBE LUB.OIL PUMP	1		5 2	1 1 1	1 1 1	1 1 1	2 1 1	1								
D2GSP14	D.O. TRANSFER PUMP			3 2	1 1 1	1 1 1	1 1 1	1 1 1	1								
D2GSP15	STEERING GEAR ROOM SUPPLY FAN				1	1	1		1								
	REMOTE I/O UNIT			2													



UNIT NAME	AC CONTACTORS	OVERLOAD RELAYS	CONTROL TRANSFORMER	FUSE	INDICATOR LIGHTS	PUSH-BUTTON	SELECTOR SWITCH	CONTACTOR RELAYS	RUN HOUR METER	TIMER RELAY	PLC
MANUFACTURE	ABB (3P AC440V 60HZ)	ABB (3P)	SHANGHAI HONGQI (60HZ)	LEGRAND	IDEC	IDEC	IDEC	IDEC FUJI	LINE	CARLO GAVAZZI	MITSUBI-SHI
NO. CIRCUIT	CIRCUIT NAME										
NO. 405 POWER DIST. BOX											
405ST1	NO.1 FRESH WATER PUMP	1		1	2	1	1	4	1		
405ST2	NO.2 FRESH WATER PUMP	1		1	1	1	1	1	1		
405ST3	NO.1 A/C COOLING FW BOOSTER PUMP	1		1	1	1	1	1	1		
405ST4	NO.2 A/C COOLING FW BOOSTER PUMP	1		1	1	1	1	1	1		
405ST5	HOT WATER CIRC.PUMP	1		1	1	1	1	1	1		
	NO. 409 POWER DIST. BOX										
409ST1	SANITARY EXH. FAN FOR ACC.	1		2	2	1	1	3	1	2	
409ST2	GALLEY SUPPLY FAN	1		3	1	1	1	1	1		
409ST3	GALLEY EXH. FAN	1		3	1	1	1	1	1		
409ST4	BATTERY ROOM EXH. FAN	1	1	5	1	1	1	1	1		
409ST6	STEERING GEAR ROOM SUPPLY FAN	1		5	1	1	1	1	1		
409ST7	CO2 ROOM EXH. FAN	1		5	1	1	1	1	1		
409ST8	AIR CON.RM EXH.FAN	1	1	5	1	1	1	1	1		
	NO.410 POWER DIST. BOX										
410ST1	ENGINEER'S WORKSHOP FAN	1		7	2	1	1	2	1	1	
410ST2	WELDING SPACE EXH. FAN	1		3	1	1	1	1	1		
410ST3	PURIFIER SPACE EXH. FAN	1		3	1	1	1	1	1		
	NO.411 POWER DIST. BOX										
411ST1	PIPE TUNNEL SUPPLY FAN	1		7	2	2	1	3	2	1	
411ST2	BOWER THRUSTER & EMERGENCY FIRE PUMP ROOM SUPPLY FAN	1		3	2	1	1	1	1		

A B C D E F G H I



POWER DIST. BOX COMPONENTS LIST

UNIT NAME	MANUFACTURE	AC CONTACTORS	OVERLOAD RELAYS	CONTROL TRANSFORMER	FUSE	INDICATOR LIGHTS	PUSH-BUTTON	SELECTOR SWITCH	CONTACTOR RELAYS	RUN HOUR METER	TIMER RELAY	PLC
		ABB (3P AC440V 60Hz)	ABB (3P)	SHANGHAI HONGQI (60Hz)	LEGRAND	IDEC	IDEC	IDEC	IDEC FUJI	LINE	CARLO GAVAZZI	MTSUBI-SHI
NO. CIRCUIT	CIRCUIT NAME	A9 A16 A26 A30 A40 A50 A63 A95 A110 A185	TA 25 DU(1.3-1.8) TA 25 DU(1.7-2.4) TA 25 DU(3.5-5.0) TA 25 DU(4.5-6.5)+DB25 TA 25 DU(6.0-8.5) TA 25 DU(7.5-11) TA 25 DU(10-14) TA 25 DU(13-19) TA 75 DU(45-63) TA 110 DU(80-110)	JBK3-30VA 450/220VAC JBK3-50VA 450/220VAC JBK3-200VA 450/220VAC JBK3-2000VA 450/220VAC	013302 013304 013306 013310	YW1P-1BEQM3 PW YW1P-1BEQM3 G YW1P-1BEQM3 R	YW1B-M1E10 G YW1B-M1E01 R	YW1S-2E10 ASLW29920EA+LSED-M3A YW1S-2E11 YW1S-3E20	RU4S-A AC220V 60HZ	SH-4(4a) AC220V SH-4(4a4b) AC220V	HK3031	DAA51 C M24 DAC01 C M24
SPECIFICATION AND TYPE												
411ST3	NO.1 UPPER DECK WALK WAY SUPPLY FAN	1										
411ST4	NO.2 UPPER DECK WALK WAY SUPPLY FAN	1										
411ST5	PAINT RM. EXH. FAN	1										
411ST6	AIR LOCK SUPPLY FAN	1										
411ST7	FORECASTLE CO2 RM EXH.FAN	1										
	NO.1 HOLD FANS GROUP STARTER PANLE											
3GSP1	NO.1 CARGO HOLD EXH. FAN(P)	1	1									
3GSP2	NO.2 CARGO HOLD EXH. FAN(P)	1										
3GSP3	NO.3 CARGO HOLD EXH. FAN(P)	1										
3GSP4	NO.4 CARGO HOLD EXH. FAN(P)	1										
3GSP5	NO.5 CARGO HOLD EXH. FAN(P)	1										
3GSP6	NO.6 CARGO HOLD EXH. FAN(P)	1	1									
	NO.2 HOLD FANS GROUP STARTER PANLE											
4GSP1	NO.1 CARGO HOLD EXH. FAN(S)	1	1									
4GSP2	NO.2 CARGO HOLD EXH. FAN(S)	1										
4GSP3	NO.3 CARGO HOLD EXH. FAN(S)	1										
4GSP4	NO.4 CARGO HOLD EXH. FAN(S)	1										
4GSP5	NO.5 CARGO HOLD EXH. FAN(S)	1										
4GSP6	NO.6 CARGO HOLD EXH. FAN(S)	1	1									
	INDIVIDUAL STARTER											
ST1	NO.4 E/R VENT.FAN (SUPPLY & EXHAUST)											
ST2	EMERG. FIRE PUMP	1	1									







A B C D E F G H I

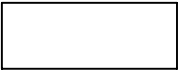
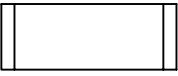
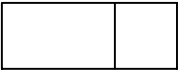
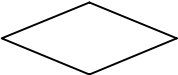
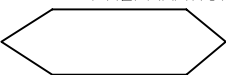

GROUP STARTER PANEL COMPONENTS LIST

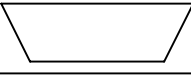
FLOWCHART SYMBOL

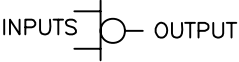
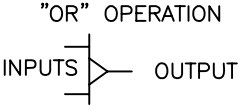
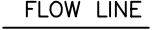
NOTE: THESE SYMBOLS ARE SHOWN IN ACCORDANCE WITH JIS C-6270

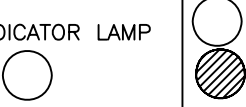
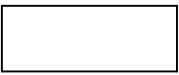
SYMBOL	DESCRIPTION
<p style="text-align: center;">PROCESS</p> 	USED TO INDICATE ANY FORM OF INTERNAL PROCESSING MANIPULATION OTHER THAN DECISIONS. AN IDENTIFYING LEGEND APPEARS IN THE BOX.
<p style="text-align: center;">PREDEFINED PROCESS</p> 	USED TO INDICATE THE PREDEFINED COMMAND GROUP SUCH LIKE SUBROUTINE IN ANOTHER PROGRAM OR ORDERED PROCESS STEPS CONSIST OF SOME OPERATIONS.
<p style="text-align: center;">CAUSE</p> 	USED TO INDICATE CONDITIONS. AN IDENTIFYING LEGEND AND A SET VALUE OF VALUES APPEAR IN THE LEFTHAND AND RIGHTHAND COLUMNS OF THE BOX, RESPECTIVELY.
<p style="text-align: center;">DECISION</p> 	USED TO INDICATE DECISION-TYPE OPERATIONS THAT DETERMINE WHICH OF A NUMBER OF ALTERNATE PATHS IS TO BE FOLLOWED. AN IDENTIFYING LEGEND APPEARS IN THE BOX.
<p style="text-align: center;">PREPARATION</p> 	USED TO INDICATE ANY PRESET CONDITION REQUIRED. AN IDENTIFYING LEGEND APPEARS IN THE BOX.
<p style="text-align: center;">TERMINAL</p> 	USED TO INDICATE THE STARTING, STOPPING, AND ENDING POINTS OF THE PROCESS STEPS. AN IDENTIFYING LEGEND APPEARS IN THE BOX
<p style="text-align: center;">MANUAL OPERATION</p> 	USED TO INDICATE POINTS IN A FLOWCHART WHERE HUMAN INTERVENTION IS REQUIRED. AN IDENTIFYING LEGEND APPEARS IN THE BOX
<p style="text-align: center;">MANUAL INPUT</p> 	USED TO INPUT A SIGNAL PRODUCED BY MANUAL OPERATION. AN IDENTIFYING LEGEND APPEARS IN THE BOX.
<p style="text-align: center;">ANNOTATION</p> 	USED FOR ADDITION OF DESCRIPTIVE COMMENTS OR EXPLANATORY NOTES.
<p style="text-align: center;">"AND" OPERATION</p> 	USED TO INDICATE "AND" OPERATIONS;THE OUTPUT IS PRESENT IF ALL INPUTS ARE PRESENT, OTHERWISE THERE IS NO OUTPUT.
<p style="text-align: center;">"OR" OPERATION</p> 	USED TO INDICATE "OR" OPERATIONS;THE OUTPUT IS PRESENT IF ONE OR MORE INPUTS ARE PRESENT.
<p style="text-align: center;">FLOW LINE</p> 	USED TO CONNECT EACH BOX AND SYMBOL IN A FLOWCHART.
<p style="text-align: center;">CONNECTOR</p> 	USED TO INDICATE CONNECTION OF FLOWCHART TO OR FROM ELSEWHERE WITH SAME NUMBER. *;NUMBER 1,2,---N.
<p style="text-align: center;">ALARM</p> 	USED TO INDICATE LIGHTING OR FLASHING OF ALARM LAMP WHICH MAY OR MAY NOT BE ASSOCIATED WITH SOUNDING OF THE AUDIBLE ALARM. AN IDENTIFYING LEGEND APPEARS IN THE FLOWCHART.
<p style="text-align: center;">INDICATOR LAMP</p> 	<p>○ INDICATES THE LAMP IS ALIGHT.</p> <p>◐ INDICATES THE LAMP IS DARK.</p> <p>AN IDENTIFYING LEGEND APPEARS AT THE TOP OF THE COLUMN.</p>
<p style="text-align: center;">(*)</p> 	*: EXPLANATORY NOTE AFFIXED TO EACH SYMBOL INDICATES DEVICE AND LOCATION (IN PARENTHESIS) OF THE CONTROL ETC.

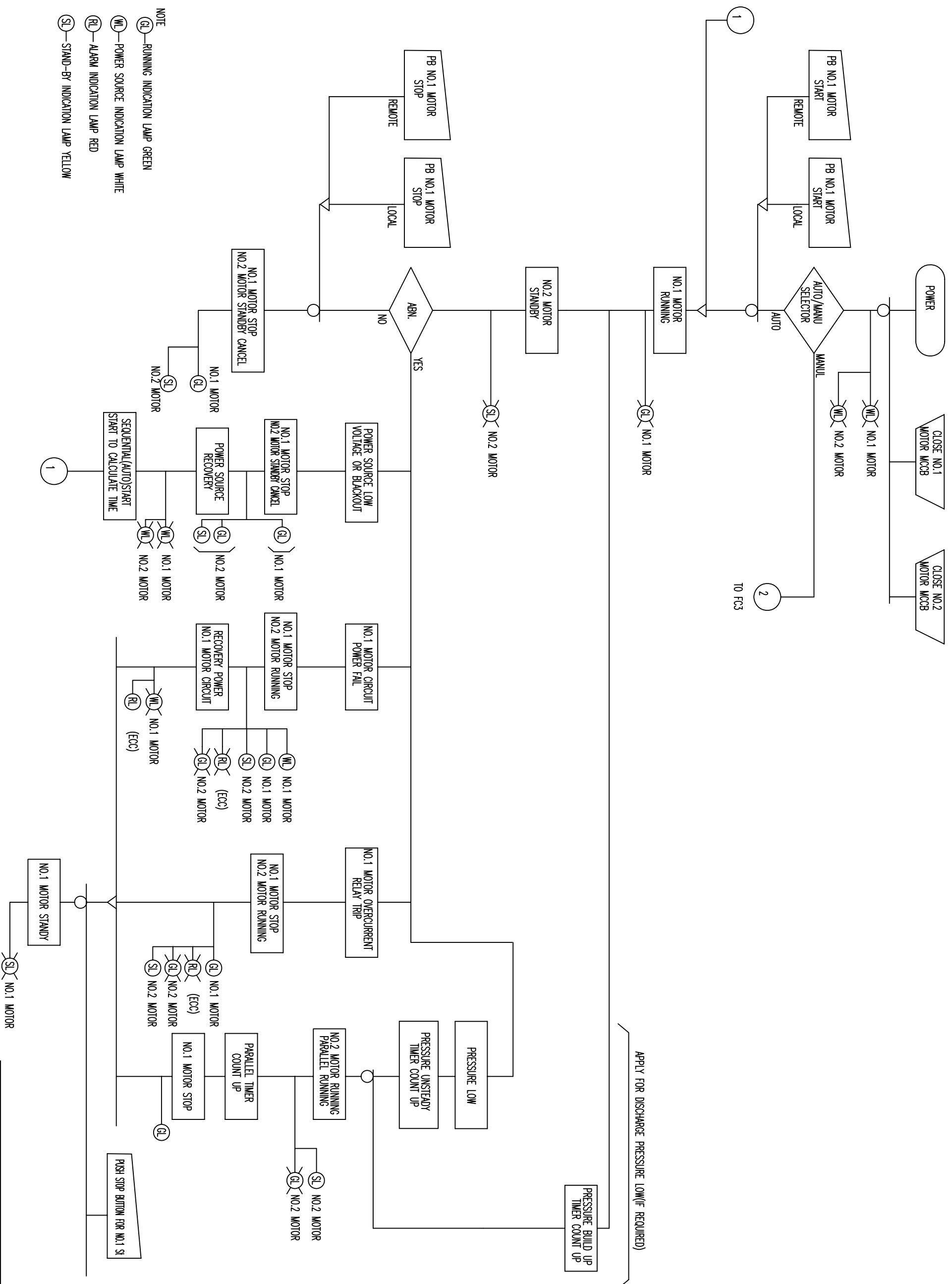

- NOTE
- (GL) — RUNNING INDICATION LAMP GREEN
 - (WL) — POWER SOURCE INDICATION LAMP WHITE
 - (RL) — ALARM INDICATION LAMP RED
 - (SL) — STAND-BY INDICATION LAMP YELLOW

A	B	C	D	E	F	G	H	I
---	---	---	---	---	---	---	---	---



AUTO CHANGEOVER FUNCTION
(IN CASE OF NO.1 MOTOR LEAD AND NO.2 MOTOR STANDBY OPERATION)

FLOWCHART

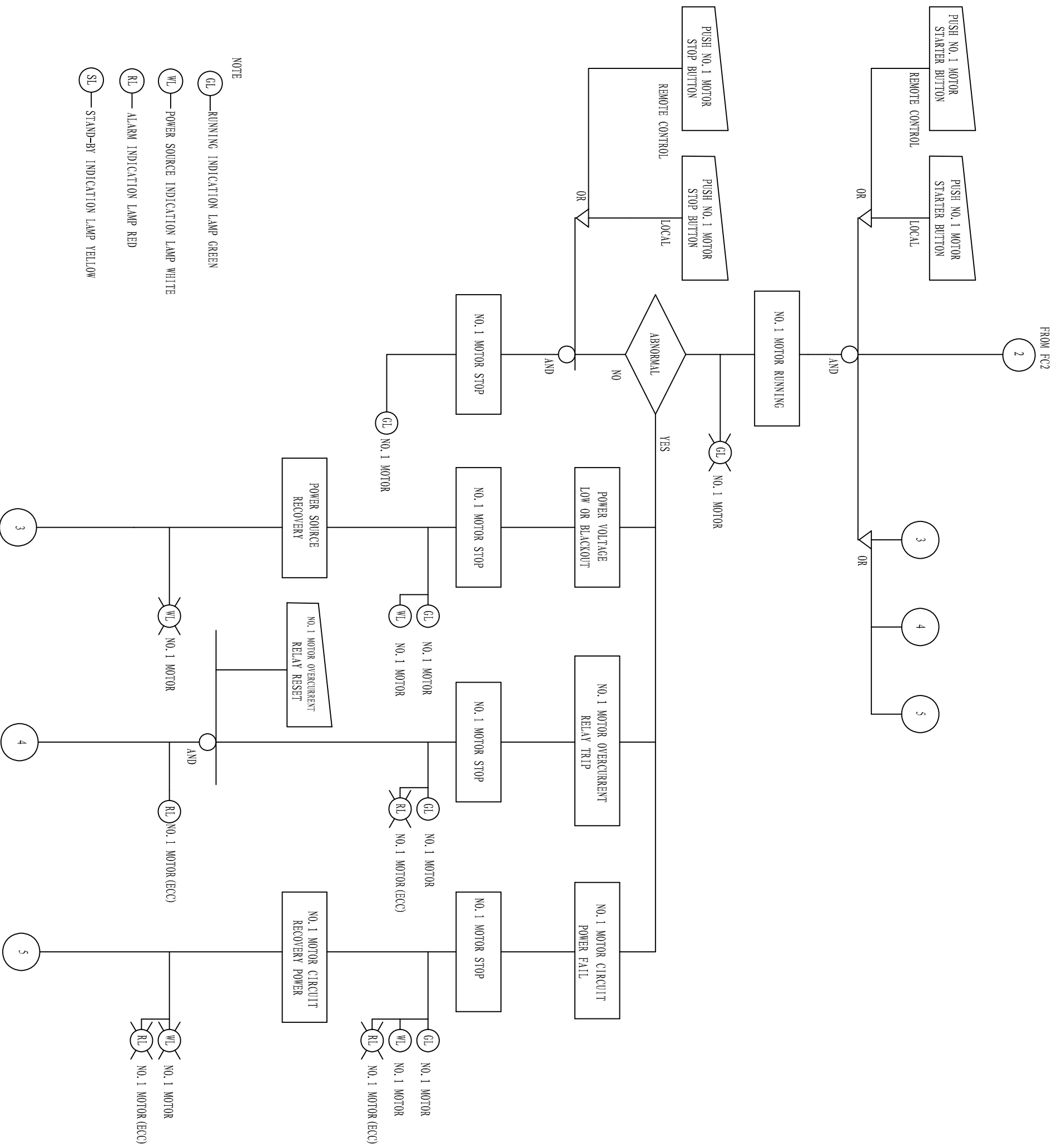

NOTE

GL—RUNNING INDICATION LAMP GREEN

WL—POWER SOURCE INDICATION LAMP WHITE

RL—ALARM INDICATION LAMP RED

SL—STAND-BY INDICATION LAMP YELLOW

A B C D E F G H I



AUTO CHANGEOVER FUNCTION
(IN CASE OF NO. 1 MOTOR LEAD AND
NO. 2 MOTOR STANDBY OPERATION)

FC2A
1-21

FLOWCHART

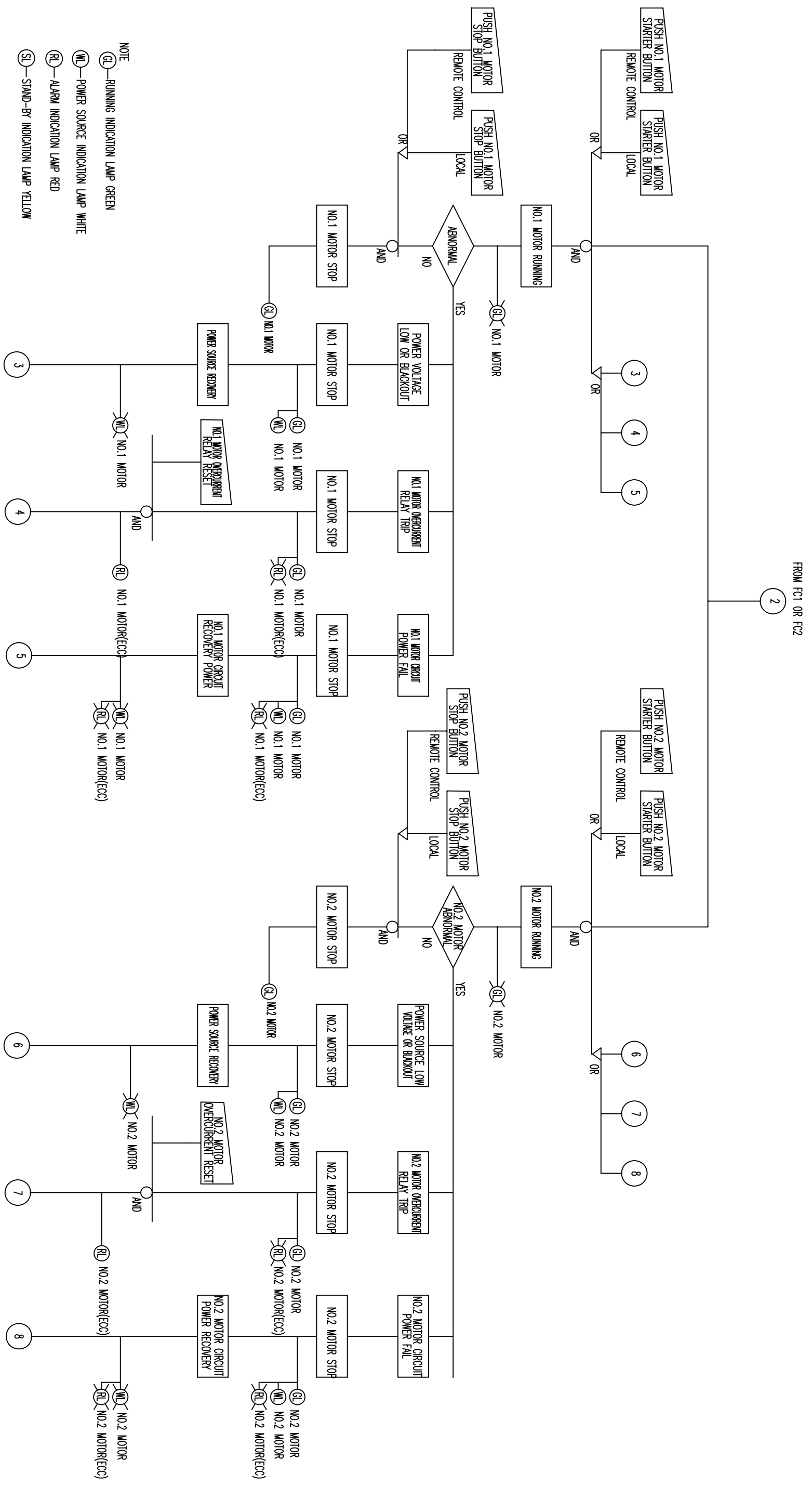

NOTE
 (GL) — RUNNING INDICATION LAMP GREEN
 (WL) — POWER SOURCE INDICATION LAMP WHITE
 (RL) — ALARM INDICATION LAMP RED
 (SL) — STAND-BY INDICATION LAMP YELLOW

A
B
C
D
E
F
G
H
I



AUTO CHANGEOVER FUNCTION
 (IN CASE OF NO.1 MOTOR & NO.2 MOTOR MANUAL OPERATION)
 FLOWCHART
 FC3
 1-22

MODE			CONDITION			FLOWCHART No. REF. TO			
No.1 STARTER	No.2 STARTER	No.3 STARTER	No.1 STARTER	No.2 STARTER	No.3 STARTER				
AUTO CHANGE	AUTO CHANGE	AUTO CHANGE	RUN	STANDBY	—	FC4A			
			—	RUN	STANDBY				
			STANDBY	—	RUN				
			AUTO CHANGE	AUTO CHANGE	AUTO CHANGE	RUN	ABNORMAL	STANDBY	FC4B
						STANDBY	RUN	ABNORMAL	
						ABNORMAL	STANDBY	RUN	
			AUTO CHANGE	AUTO CHANGE	AUTO CHANGE	RUN	RUN	STANDBY	FC4C FC4D
						STANDBY	RUN	RUN	
						RUN	STANDBY	RUN	
AUTO CHANGE	AUTO CHANGE	MANUAL	RUN	STANDBY	/	FC2			
			STANDBY	RUN	/				
MANUAL	AUTO CHANGE	AUTO CHANGE	/	RUN	STANDBY				
			/	STANDBY	RUN				
AUTO CHANGE	MANUAL	AUTO CHANGE	STANDBY	/	RUN				
			RUN	/	STANDBY				

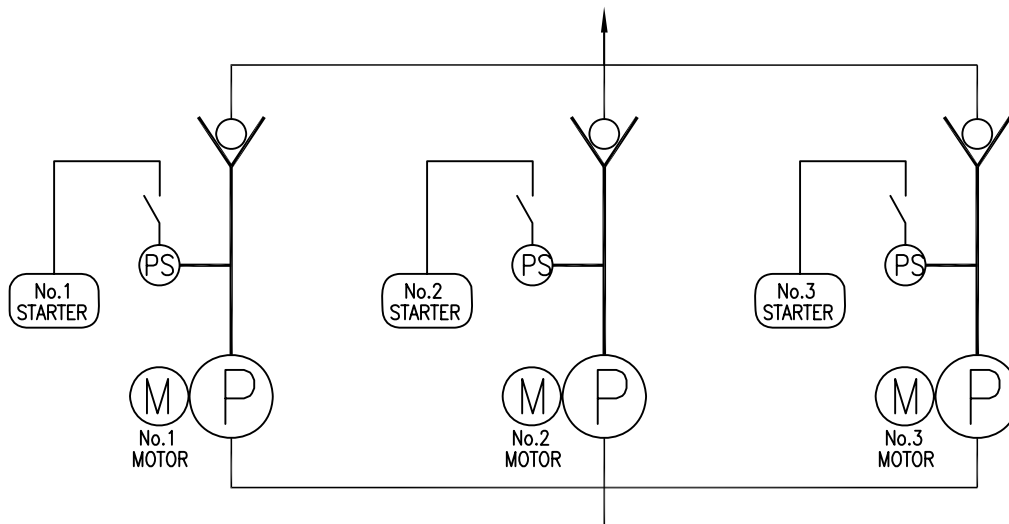

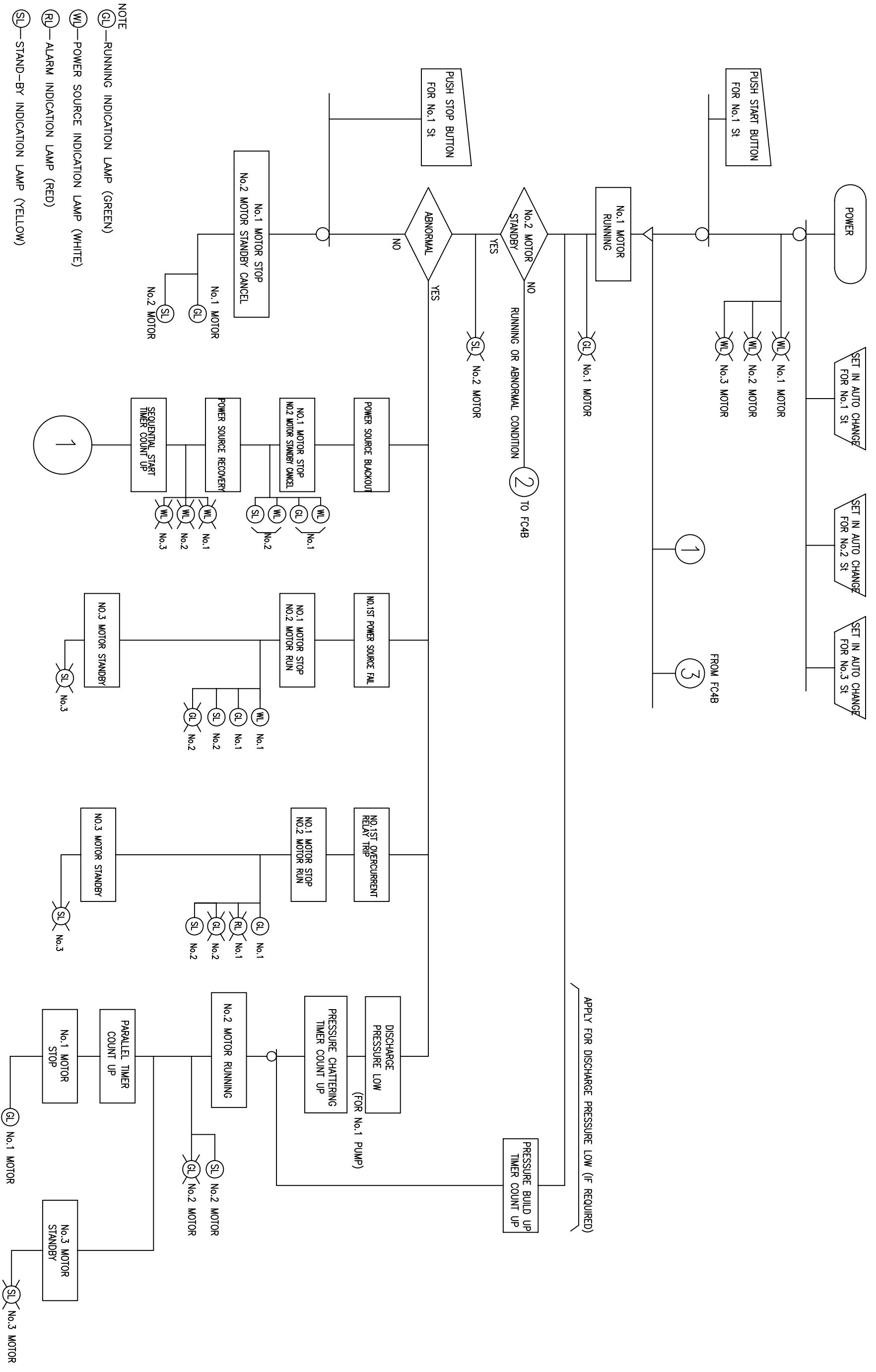

NOTE

- (GL) — RUNNING INDICATION LAMP (GREEN)
- (WL) — POWER SOURCE INDICATION LAMP (WHITE)
- (RL) — ALARM INDICATION LAMP (RED)
- (SL) — STAND-BY INDICATION LAMP (YELLOW)

A	B	C	D	E	F	G	H	I
---	---	---	---	---	---	---	---	---



IN CASE OF No. 1 MOTOR RUN AND No. 2 MOTOR
STANDBY OPERATION

FLOWCHART

- NOTE
- (GL) — RUNNING INDICATION LAMP (GREEN)
 - (WL) — POWER SOURCE INDICATION LAMP (WHITE)
 - (RL) — ALARM INDICATION LAMP (RED)
 - (SL) — STAND-BY INDICATION LAMP (YELLOW)

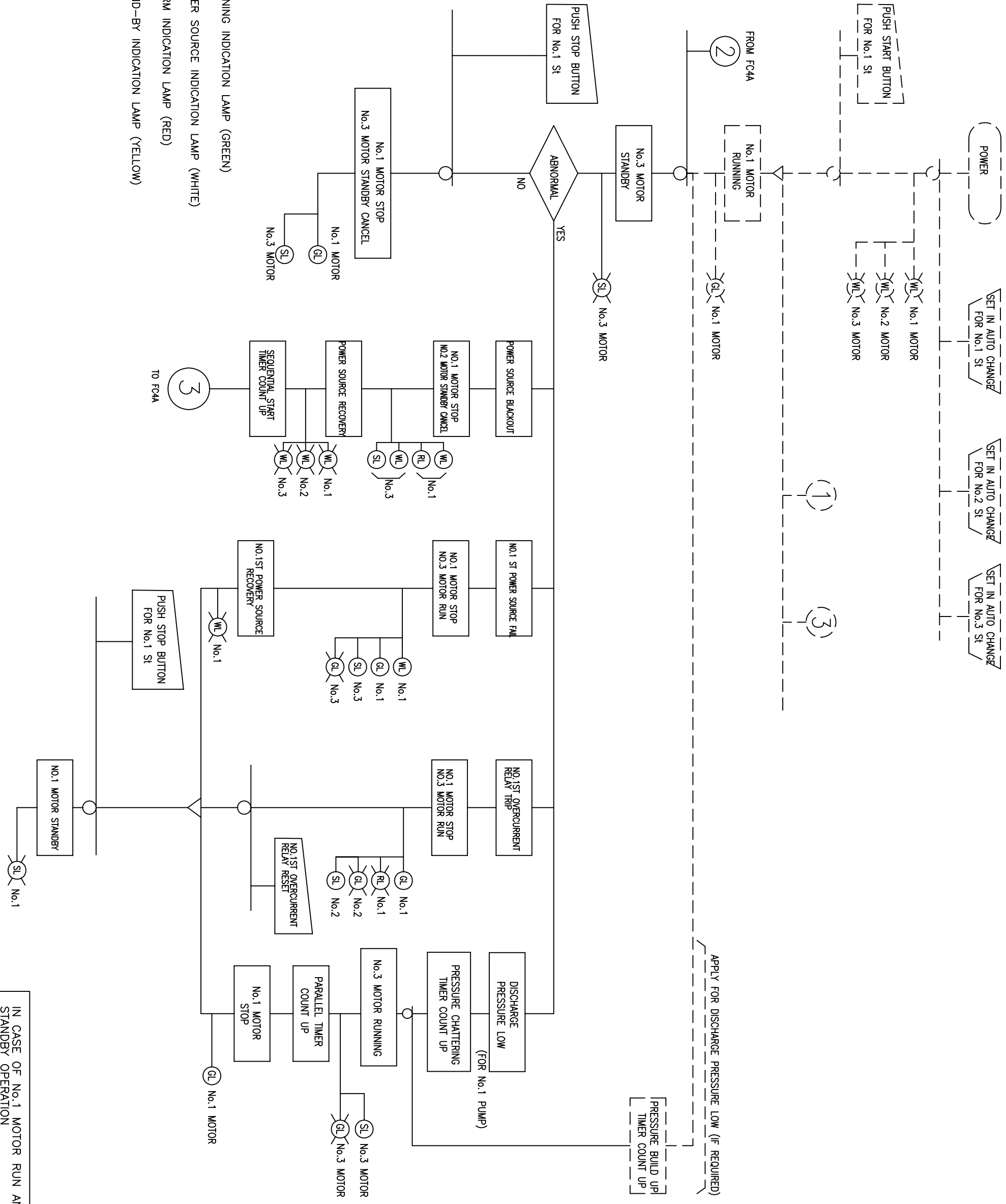

A	B	C	D	E	F	G	H	I
---	---	---	---	---	---	---	---	---



IN CASE OF NO.1 MOTOR RUN AND NO.3 MOTOR STANDBY OPERATION

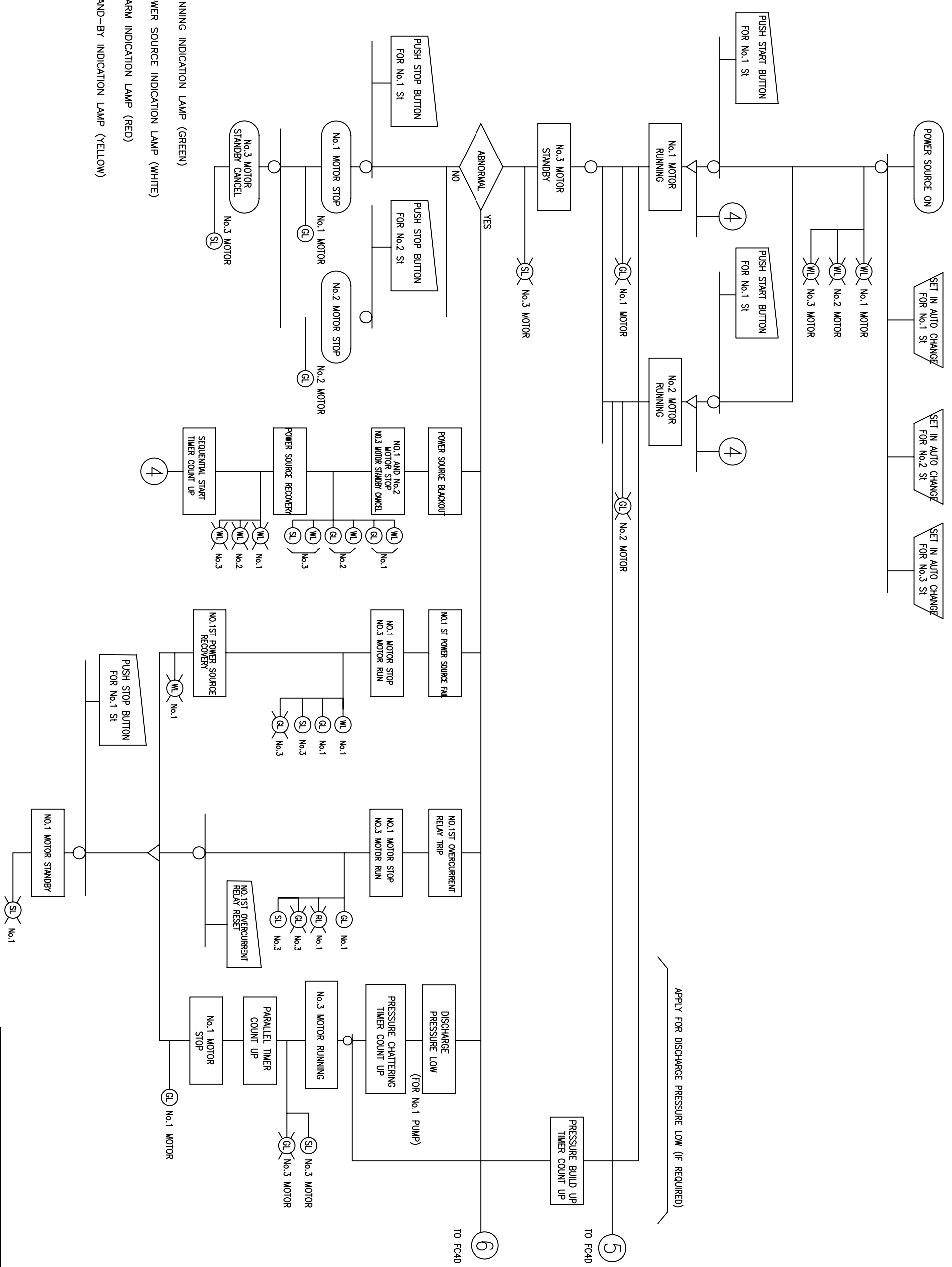

- NOTE
- GL—RUNNING INDICATION LAMP (GREEN)
 - WL—POWER SOURCE INDICATION LAMP (WHITE)
 - RL—ALARM INDICATION LAMP (RED)
 - SL—STAND-BY INDICATION LAMP (YELLOW)

A	B	C	D	E	F	G	H	I
---	---	---	---	---	---	---	---	---



IN CASE OF No.1 MOTOR RUN AND No.2 MOTOR
 RUN AND No.3 MOTOR STANDBY OPERATION

FC4C
 1-27

APPLY FOR DISCHARGE PRESSURE LOW (IF REQUIRED)

5
FROM FC4C

PRESSURE BUILD UP
TIMER COUNT UP

6
FROM FC4C

NO.2 ST POWER SOURCE FAIL

NO.2ST OVERCURRENT
RELAY TRIP

DISCHARGE
PRESSURE LOW
(FOR No.1 PUMP)

NO.2 MOTOR STOP
NO.3 MOTOR RUN

NO.2 MOTOR STOP
NO.3 MOTOR RUN

PRESSURE CHATTERING
TIMER COUNT UP

NOTE
GL—RUNNING INDICATION LAMP (GREEN)
WL—POWER SOURCE INDICATION LAMP (WHITE)

RL—ALARM INDICATION LAMP (RED)
SL—STAND-BY INDICATION LAMP (YELLOW)

NO.2ST POWER SOURCE
RECOVERY

NO.2ST OVERCURRENT
RELAY RESET

No.2 MOTOR
STOP

PUSH STOP BUTTON
FOR No.2 St

NO.2 MOTOR STANDBY

SL No.2

GL No.2 MOTOR

WL No.2
GL No.2
SL No.3
GL No.3

GL No.2
RL No.2
GL No.3
SL No.3

No.3 MOTOR RUNNING

SL No.3 MOTOR
GL No.3 MOTOR

SL—STAND-BY INDICATION LAMP (YELLOW)

A B C D E F G H I



FC4D
1-28

IN CASE OF No.1 MOTOR RUN AND No.2 MOTOR
RUN AND No.3 MOTOR STANDBY OPERATION

FLOWCHART

No.1 GSP

2475

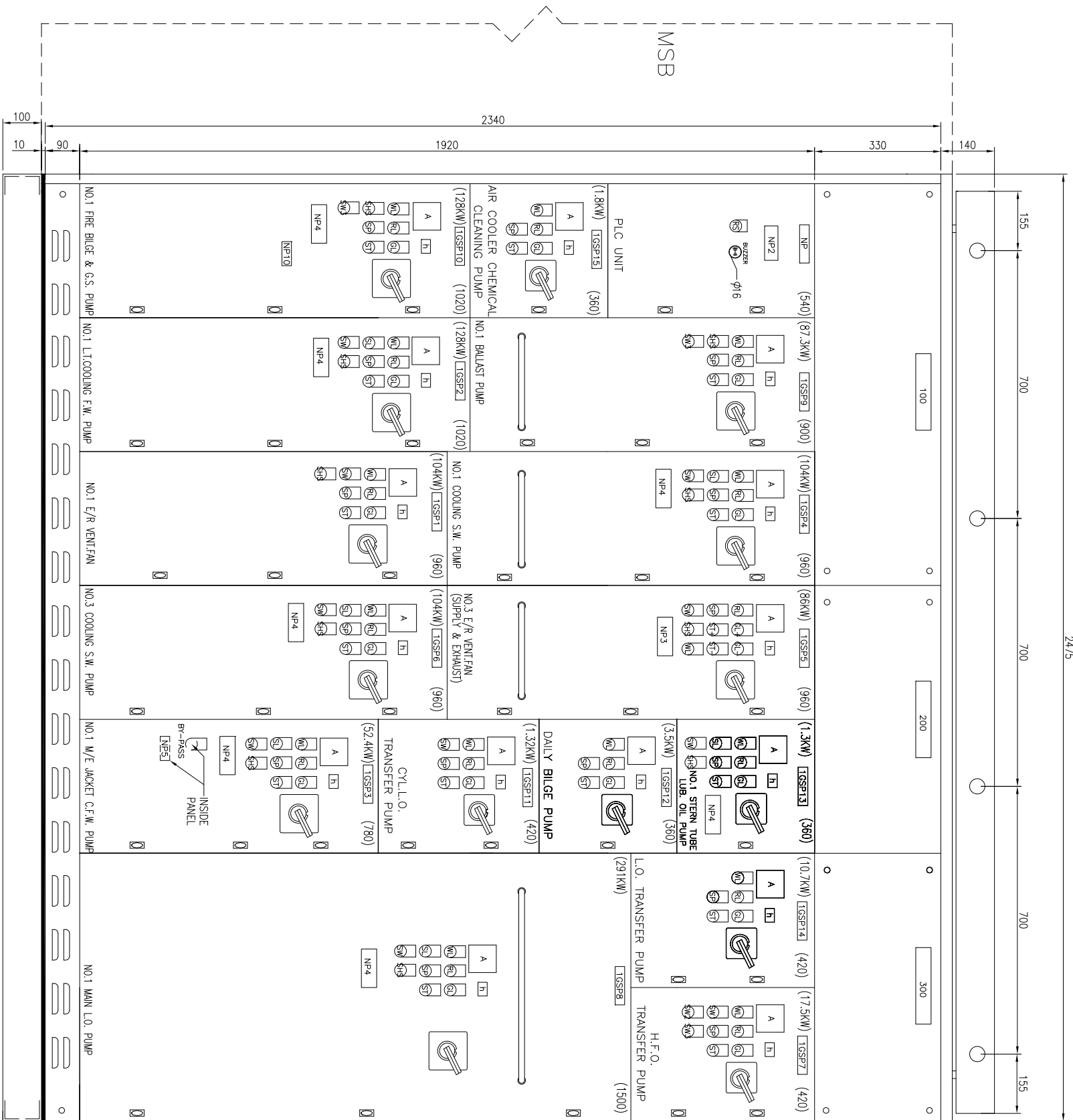

FRONT VIEW

NOTE:

- WL--(POWER) WHITE
 - GL--(RUNNING) GREEN
 - GL+--(SUPPLY RUNNING) GREEN
 - GL---(EXHAUST RUNNING) GREEN
 - RL--(TRIP) RED
 - ST+--(SUPPLY FAN START) GREEN
 - ST---(EXHAUST FAN START) GREEN
 - SP---(STOP) RED
 - SW---(SELECT MODE)
 - SHS---(SPACE HEATER SELECTION SWITCH)
 - SL---(STANDBY) YELLOW
 - SW1---(SELECT MODE)
 - SW2---(SELECT MODE)
- THE PLASTIC PLATE SHOULD BE INSTALLED TO PREVENT TOUCHING ALIVE BUS BAR WHEN REMOVE THE COVER OF NO.1 & 2 GSP.

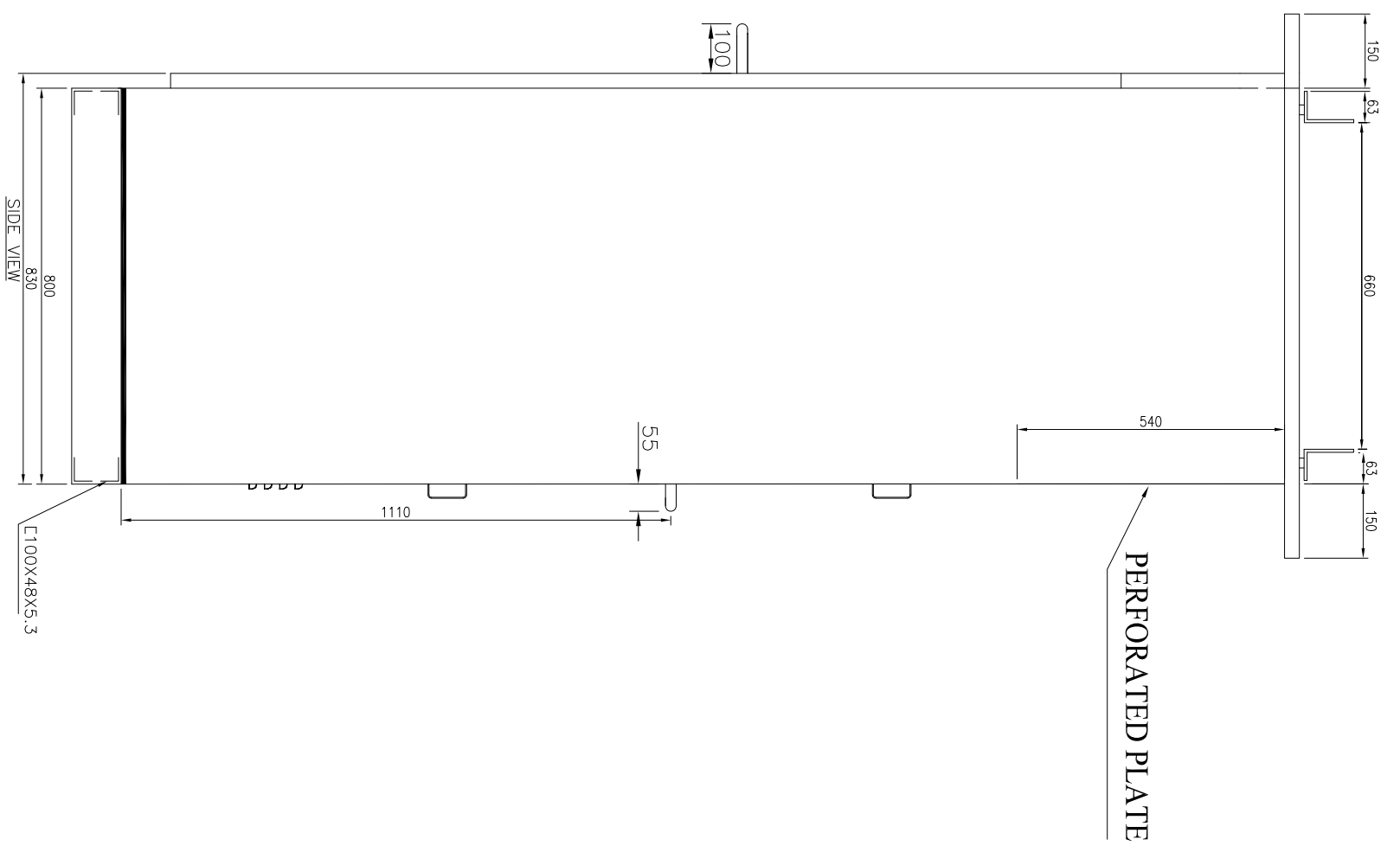

SIDE VIEW

A B C D E F G H I



NO.1 GSP
OUTLINE VIEW
OV1
1-29

No.2 GSP

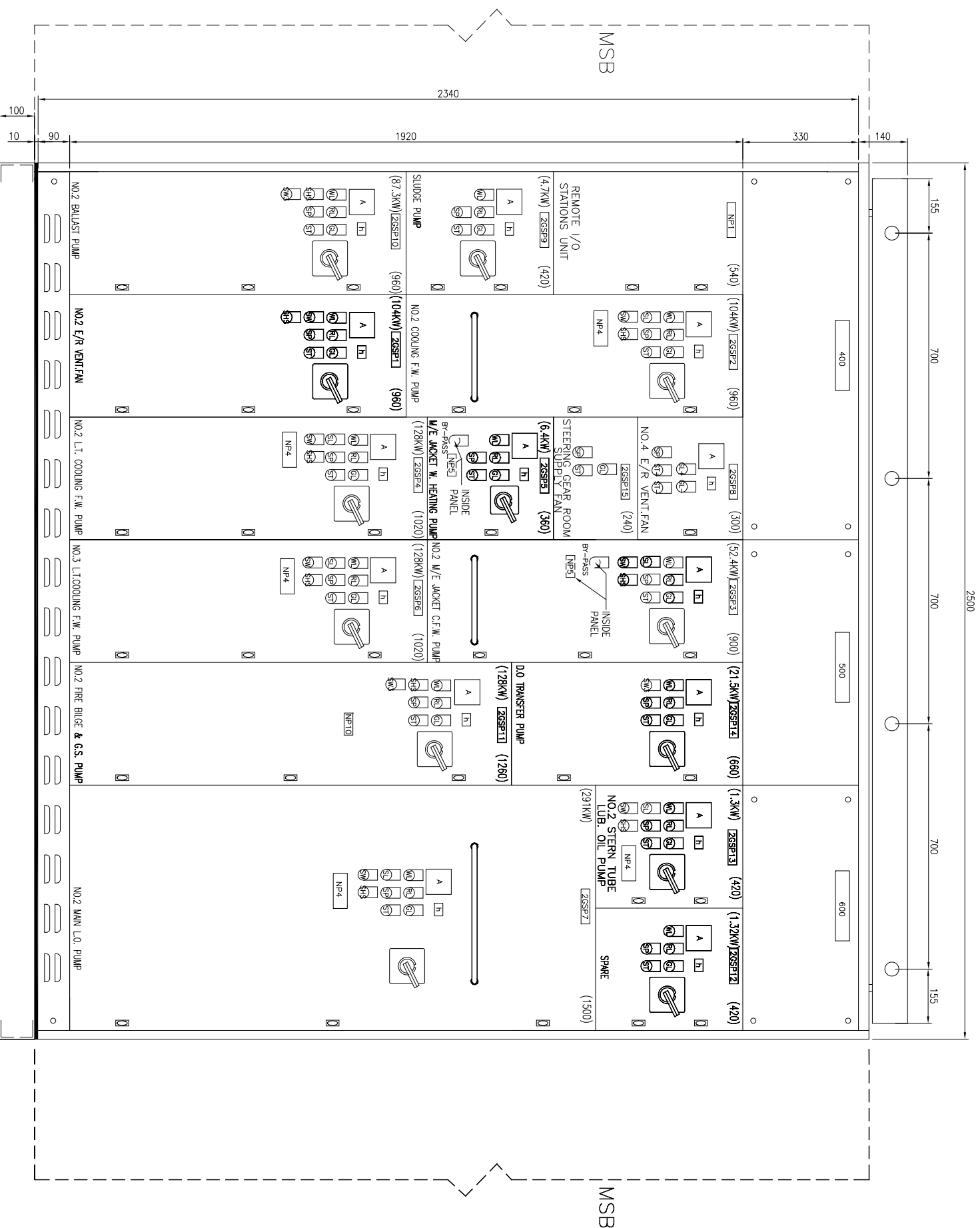

FRONT VIEW

NOTE:

- WL---(POWER) WHITE
 - GL---(RUNNING) GREEN
 - GL+---(SUPPLY RUNNING) GREEN
 - GL---(EXHAUST RUNNING) GREEN
 - RL---(TRIP) RED
 - ST+---(SUPPLY FAN START) GREEN
 - ST---(EXHAUST FAN START) GREEN
 - SP---(STOP) RED
 - SW---(SELECT MODE)
 - SHS---(SPACE HEATER SELECTION SWITCH)
 - SL---(STANDBY) YELLOW
 - SW1---(SELECT MODE)
 - SW2---(SELECT MODE)
- THE PLASTIC PLATE SHOULD BE INSTALLED TO PREVENT TOUCHING ALIVE BUS BAR WHEN REMOVE THE COVER OF NO.1 & 2 GSP.

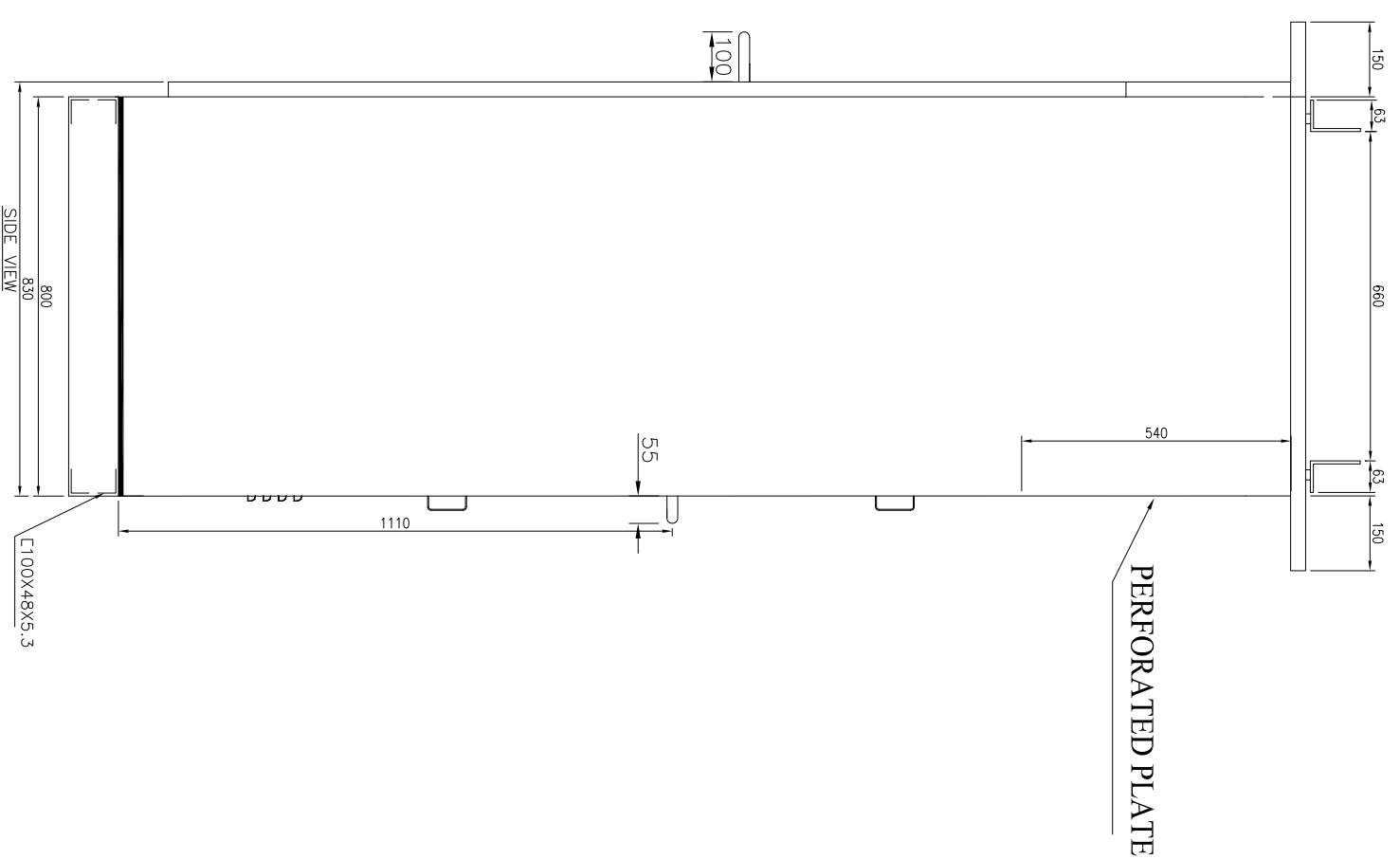

PERFORATED PLATE

SIDE VIEW

A B C D E F G H I



OUTLINE VIEW

OV2

1-30

NO.2 GSP

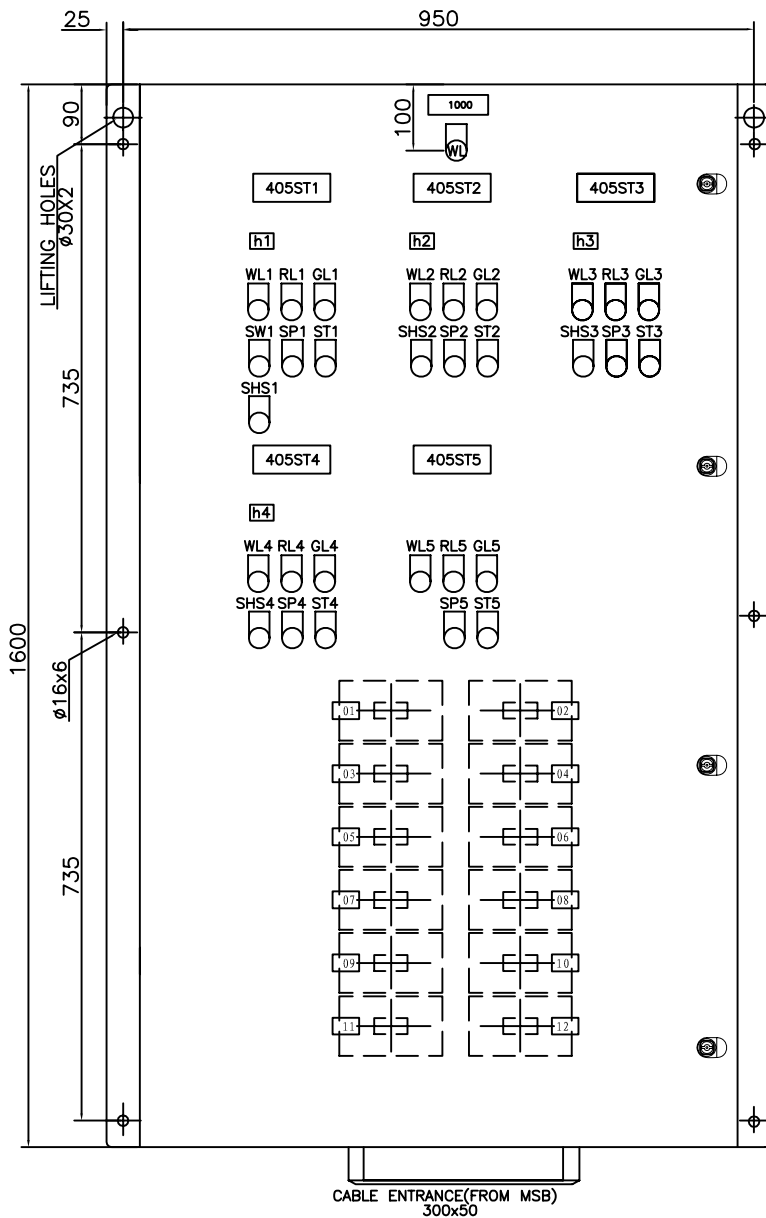

FRONT VIEW

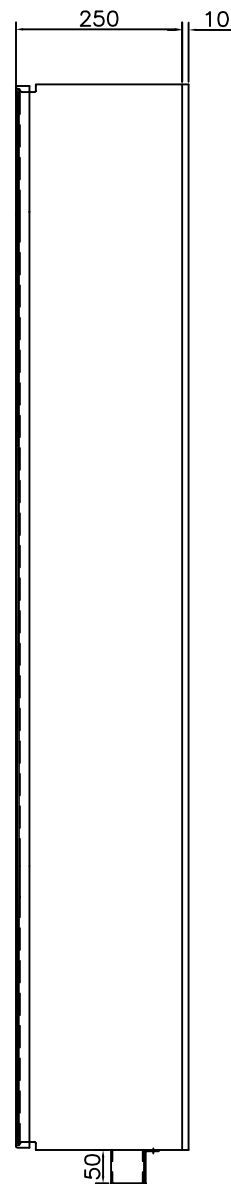

RIGHT SIDE VIEW

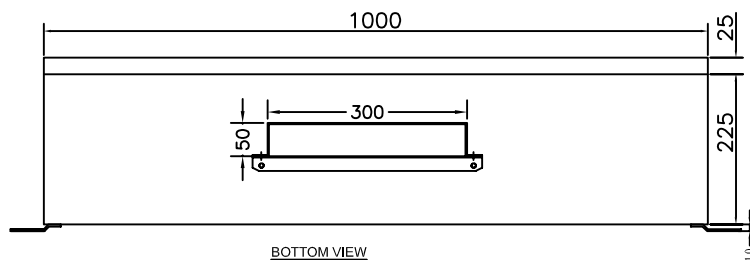

BOTTOM VIEW

NOTE:

- ST1-5: START BUTTON(GREEN)
- ST+: START BUTTON(GREEN)
- ST-: START BUTTON(GREEN)
- SP1-5: STOP BUTTON(RED)
- SW1-2: SELECT SWITCH(BLACK)
- WL1-5: POWER SOURCE INDICATOR(WHITE)
- GL1-5: RUNNING INDICATOR(GREEN)
- RL1-5: ALARM(RED)
- PROTECTION DEGREE: IP23
- THIS DIST BOX FOR:NO. 405
- MCCB:XH100NS 3P PM, 12 PIECES

NO.405 POWER DIST. BOX



OUTLINE VIEW

OV405

1-31

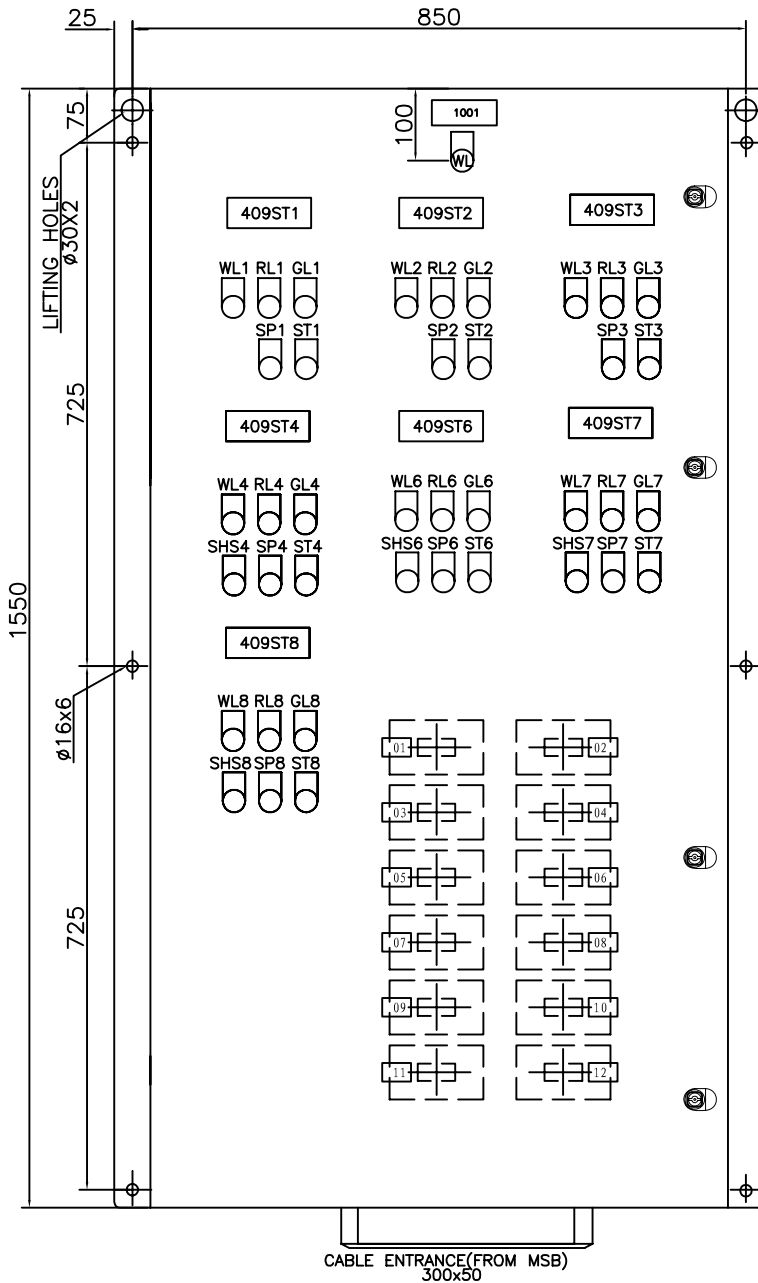

FRONT VIEW

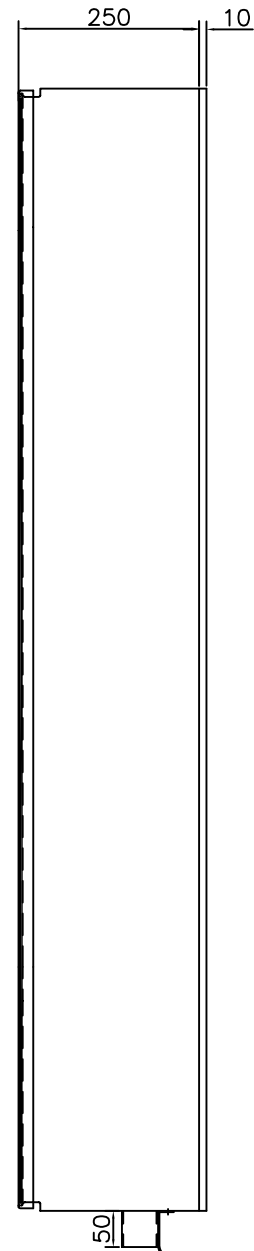

RIGHT SIDE VIEW

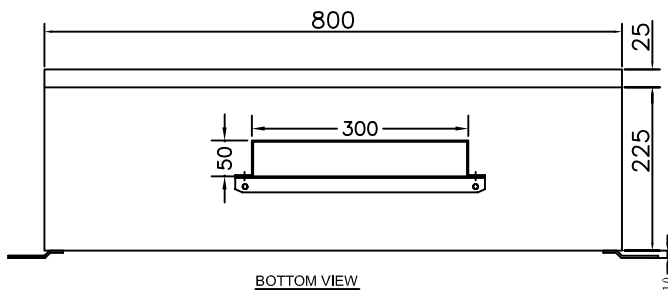

BOTTOM VIEW

NOTE:

- ST1-8: START BUTTON(GREEN)
- ST+: START BUTTON(GREEN)
- ST-: START BUTTON(GREEN)
- SP1-8: STOP BUTTON(RED)
- WL1-8: POWER SOURCE INDICATOR(WHITE)
- GL1-8: RUNNING INDICATOR(GREEN)
- RL1-8: ALARM(RED)
- PROTECTION DEGREE: IP23
- THIS DIST BOX FOR:NO. 409
- MCCB:XE100NS 3P PM, 12 PIECES

NO.409 POWER DIST. BOX

OUTLINE VIEW

OV409

1-32



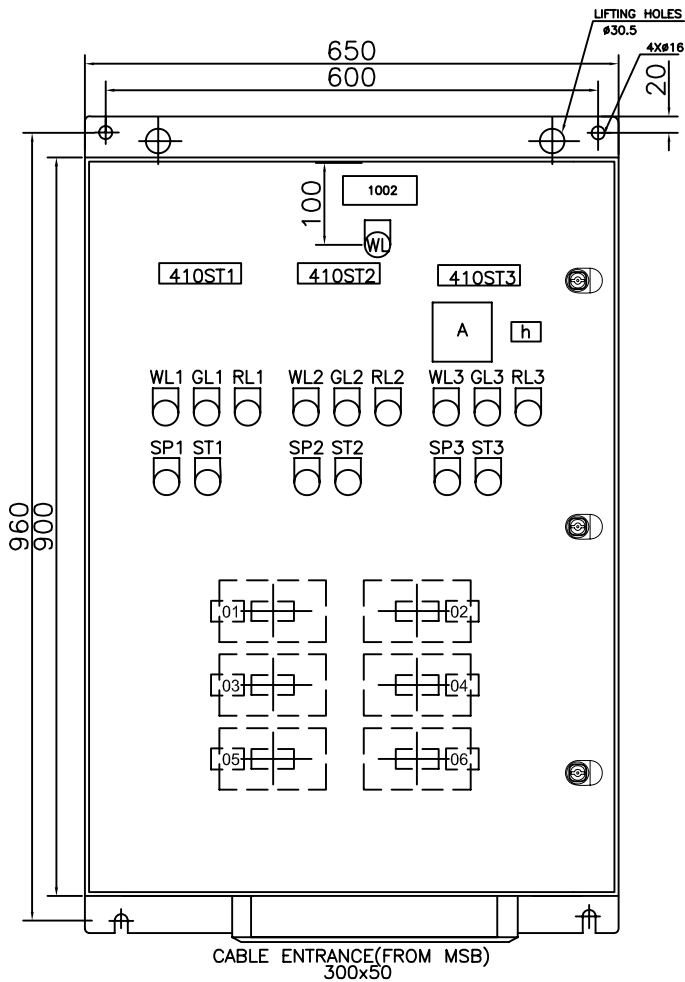

CABLE ENTRANCE(FROM MSB)
300x50

FRONT VIEW

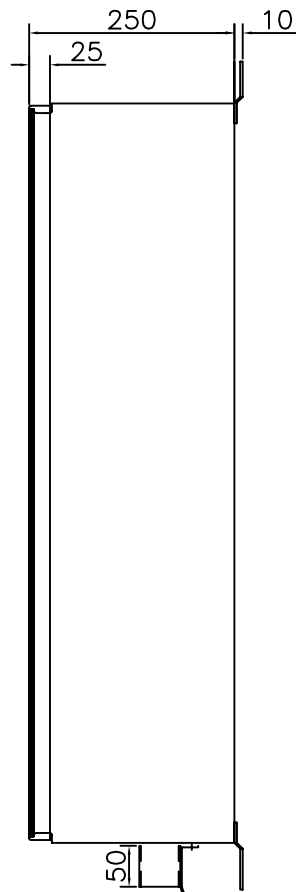

SIDE VIEW

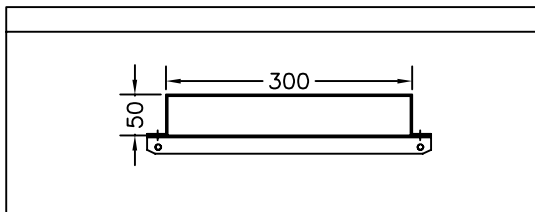

BOTTOM VIEW

NOTE:

- ST1-3: START BUTTON(GREEN)
- ST+: START BUTTON(GREEN)
- ST-: START BUTTON(GREEN)
- SP1-3: STOP BUTTON(RED)
- WL1-3: POWER SOURCE INDICATOR(WHITE)
- GL1-3: RUNNING INDICATOR(GREEN)
- RL1-3: ALARM(RED)
- PROTECTION DEGREE: IP23
- THIS DIST BOX FOR:NO. 410
- MCCB:XE100NS 3P PM, 6 PIECES

NO.410 POWER DIST. BOX

OUTLINE VIEW

OV410

1-33

A B C D E F G H I



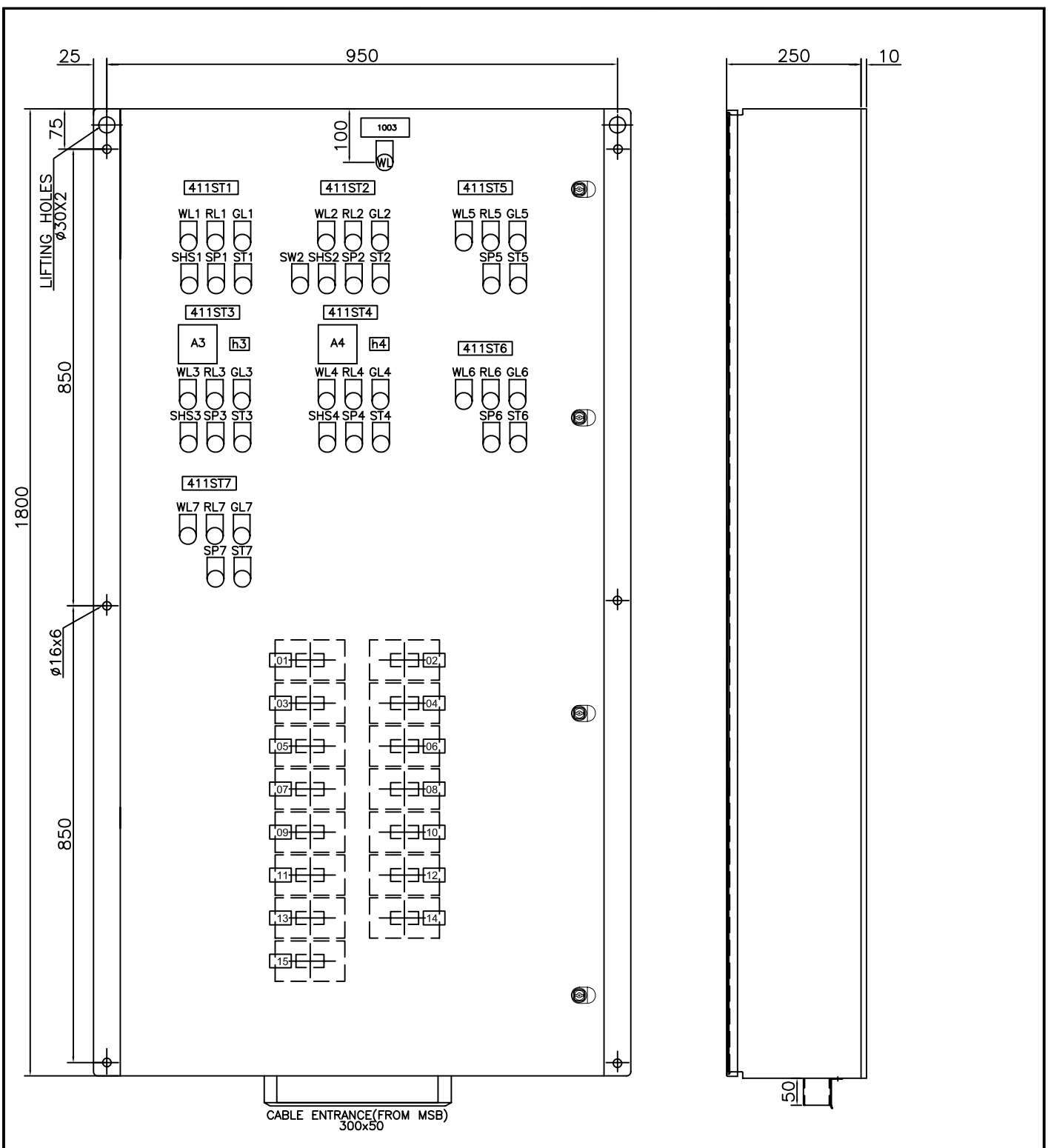

FRONT VIEW

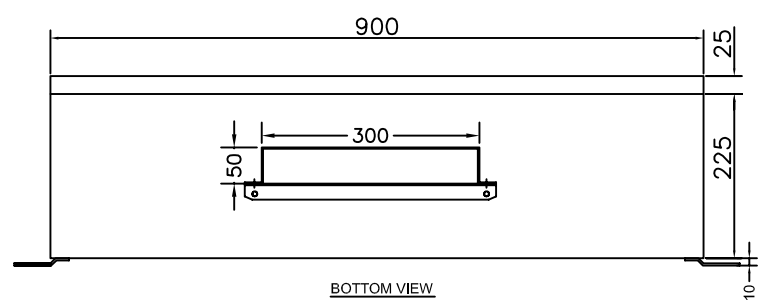

BOTTOM VIEW

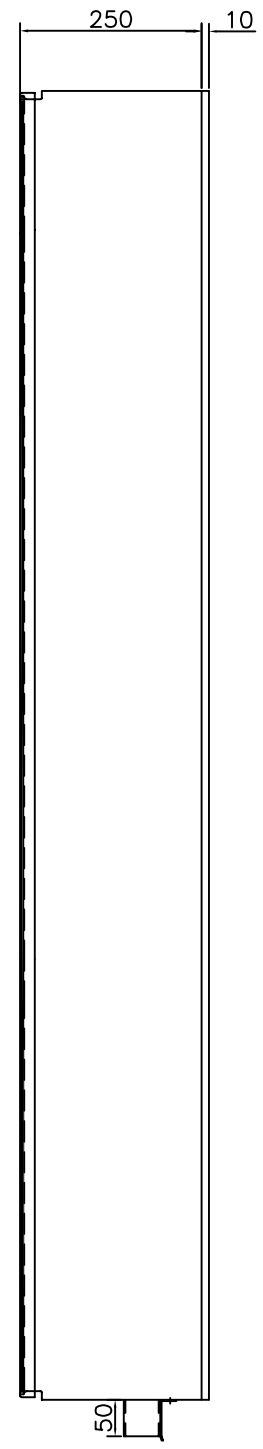

NOTE:

- ST1-6: START BUTTON(GREEN)
- ST+: START BUTTON(GREEN)
- ST-: START BUTTON(GREEN)
- SP1-6: STOP BUTTON(RED)
- WL1-6: POWER SOURCE INDICATOR(WHITE)
- GL1-6: RUNNING INDICATOR(GREEN)
- RL1-6: ALARM(RED)
- PROTECTION DEGREE: IP23
- THIS DIST BOX FOR:NO. 411
- MCCB:XE100NS 3P PM, 15 PIECES

NO.411 POWER DIST. BOX

A	B	C	D	E	F	G	H	I
---	---	---	---	---	---	---	---	---



OUTLINE VIEW

OV411
1-34

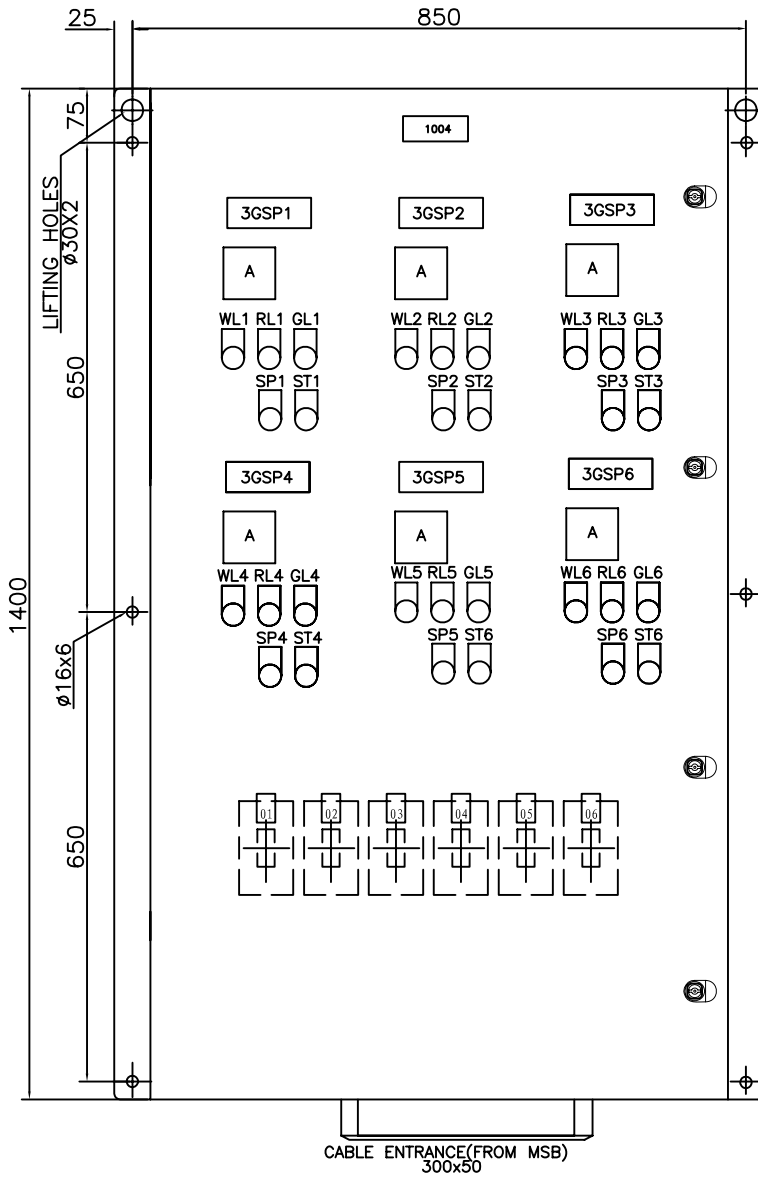

FRONT VIEW

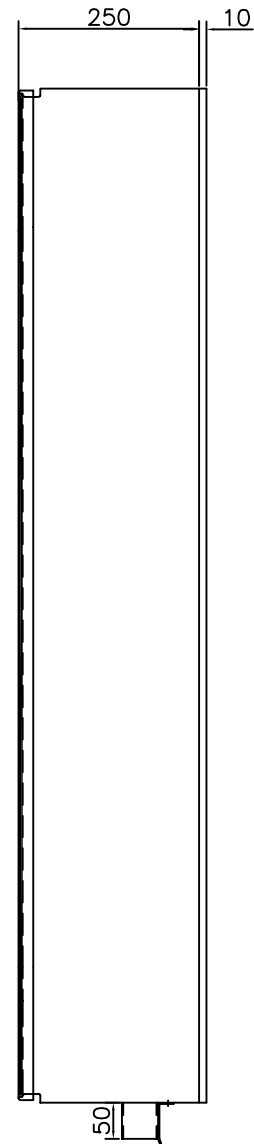

RIGHT SIDE VIEW

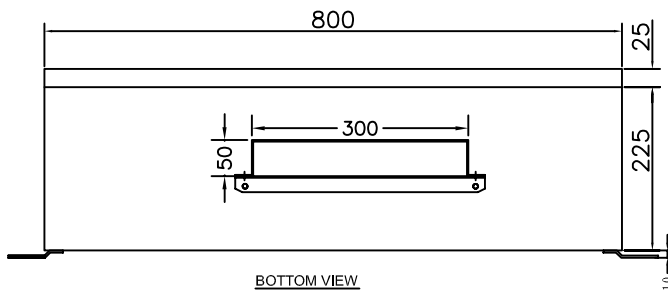

BOTTOM VIEW

- ST1-6: START BUTTON(GREEN)
 - ST-: REVERSION START(GREEN)
 - SP1-6: STOP BUTTON(RED)
 - WL1-6: POWER SOURCE INDICATOR(WHITE)
 - RL1-6: ALARM(RED)
 - GL1-6: RUNNING INDICATOR(GREEN)
- PROTECTION DEGREE:IP23.

NO.1 HOLD FANS GROUP STARTER PANEL

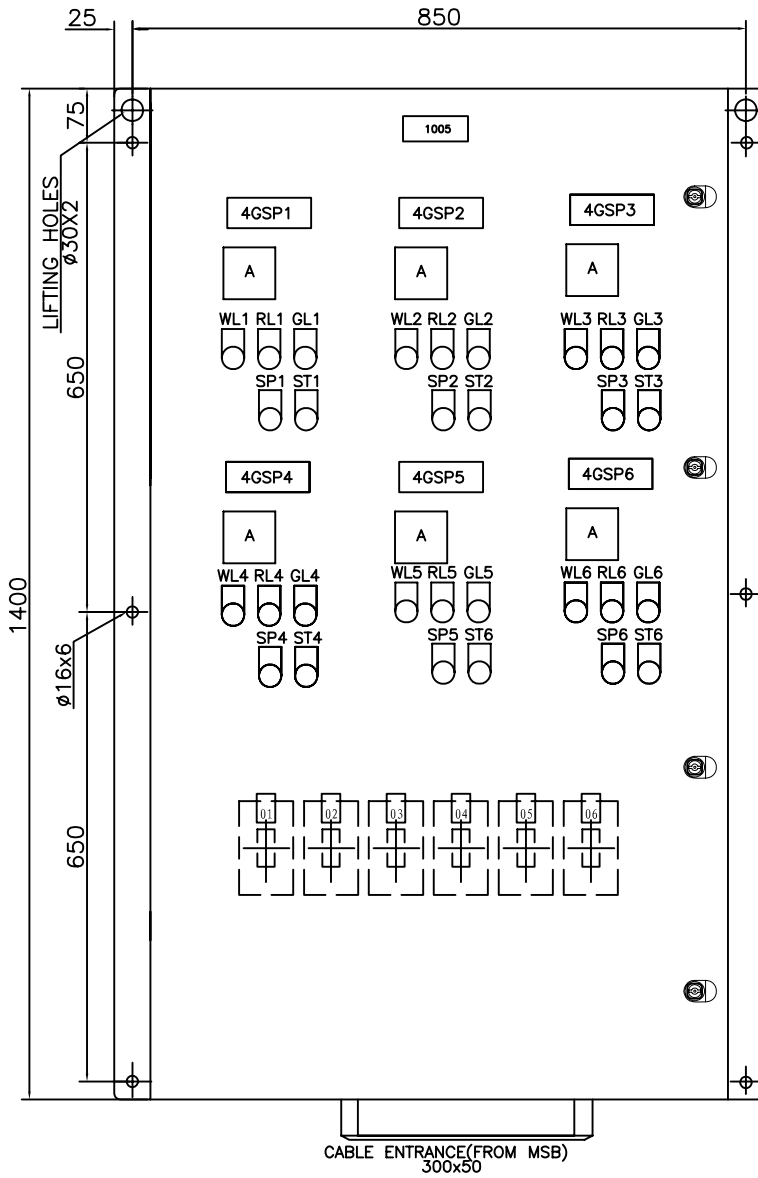

FRONT VIEW

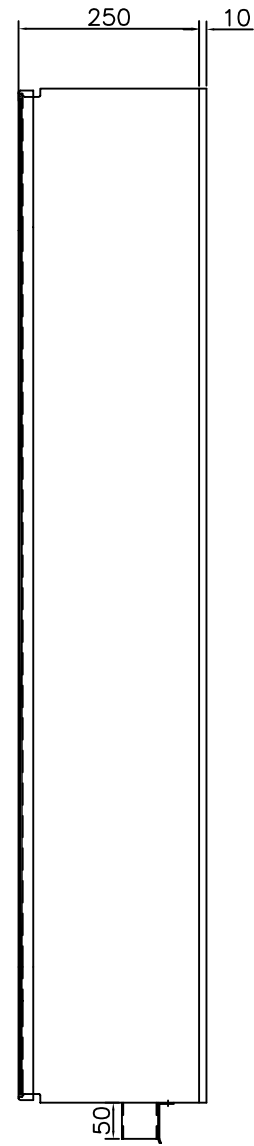

RIGHT SIDE VIEW

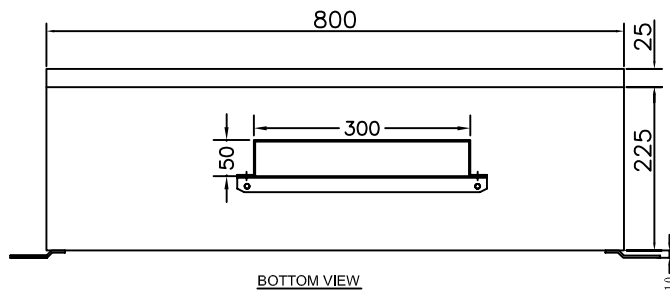

BOTTOM VIEW

- ST1-6: START BUTTON(GREEN)
 - ST-: REVERSION START(GREEN)
 - SP1-6: STOP BUTTON(RED)
 - WL1-6: POWER SOURCE INDICATOR(WHITE)
 - RL1-6: ALARM(RED)
 - GL1-6: RUNNING INDICATOR(GREEN)
- PROTECTION DEGREE:IP23.

NO.2 HOLD FANS GROUP STARTER PANEL



OUTLINE VIEW

OVCH2

1-36

Ⓐ B C D E F G H I

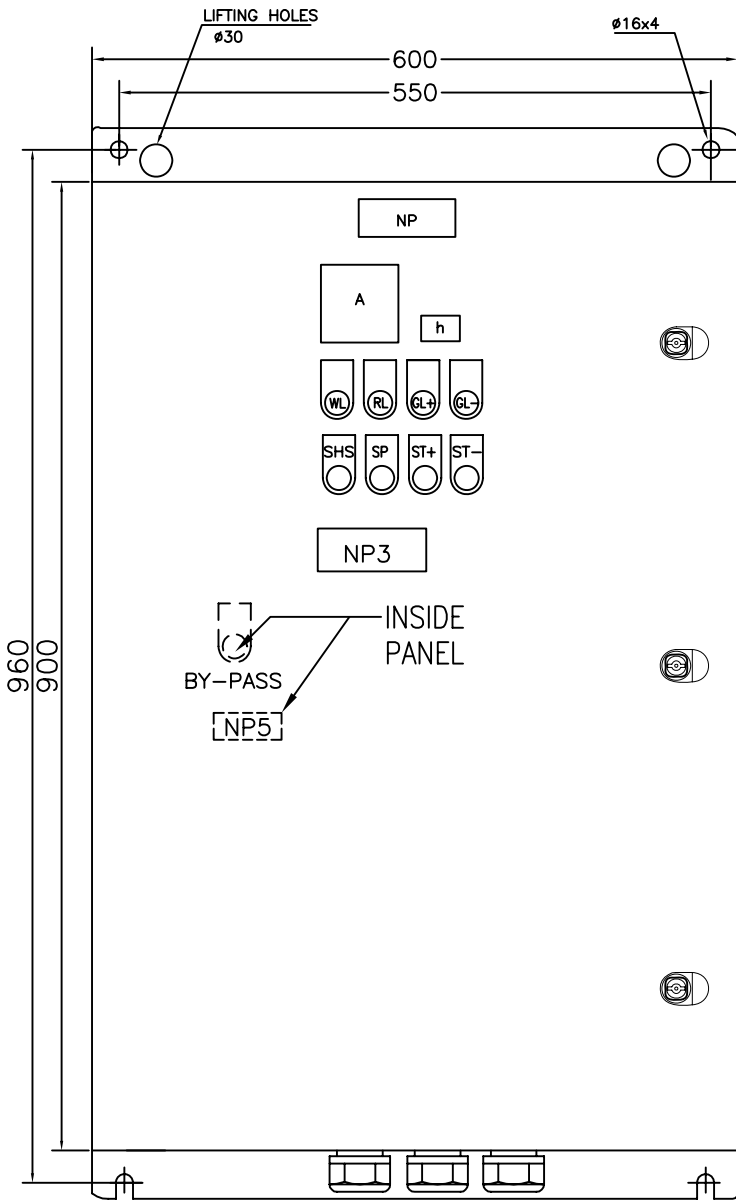

FRONT VIEW

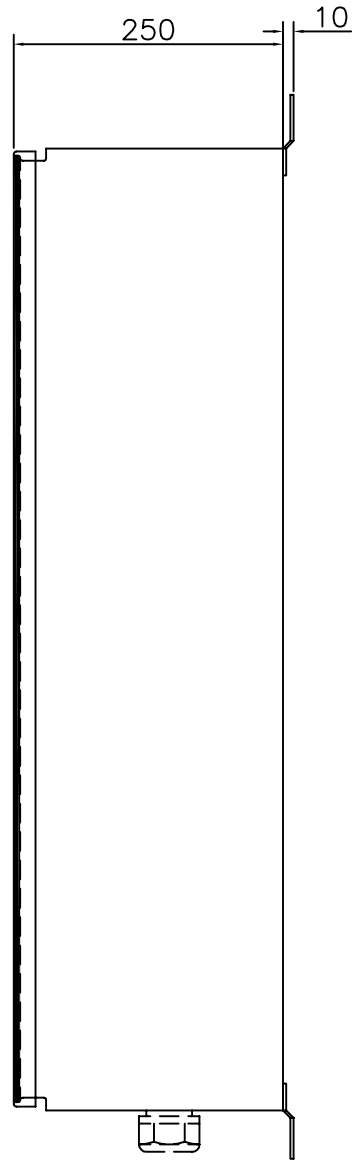

RIGHT SIDE VIEW

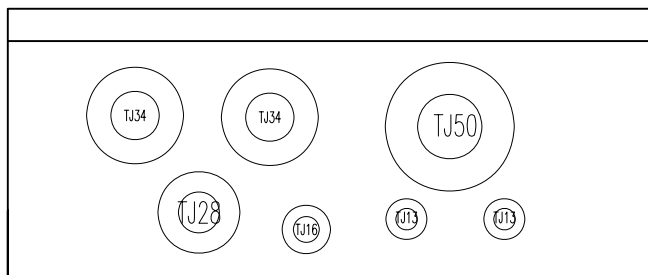

BOTTOM VIEW

NOTE:

- ST: START BUTTON(GREEN)
- ST+: START BUTTON(GREEN)
- ST-: START BUTTON(GREEN)
- SP: STOP BUTTON(RED)
- WL: POWER SOURCE INDICATOR(WHITE)
- GL: RUNNING INDICATOR(GREEN)
- RL: ALARM(RED)
- PROTECTION DEGREE: IP44

NO.4 E/R VENT. FAN(SUPPLY & EXHAUST)

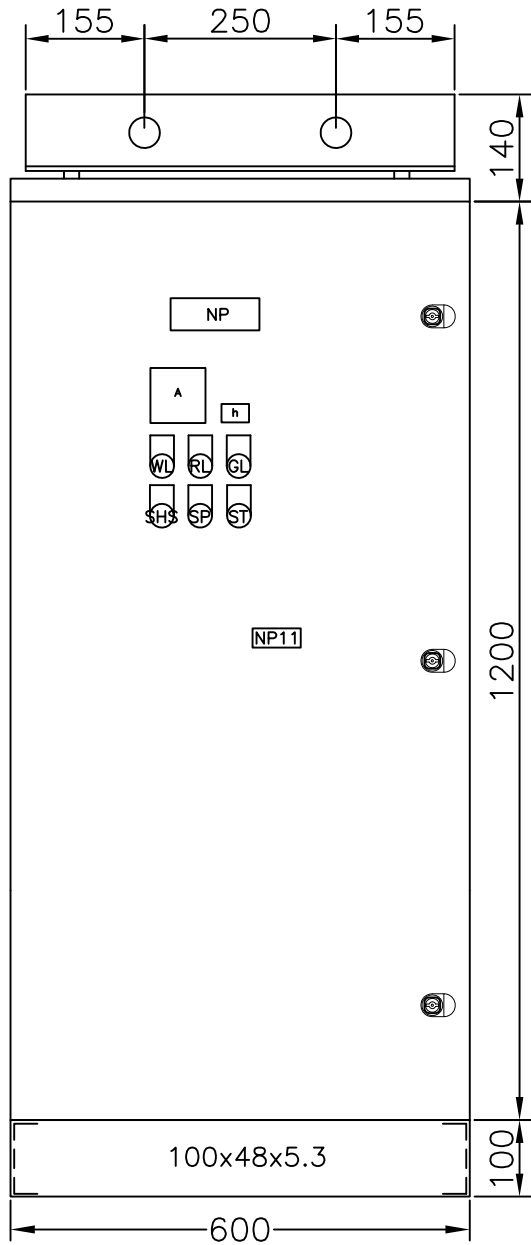

FRONT VIEW

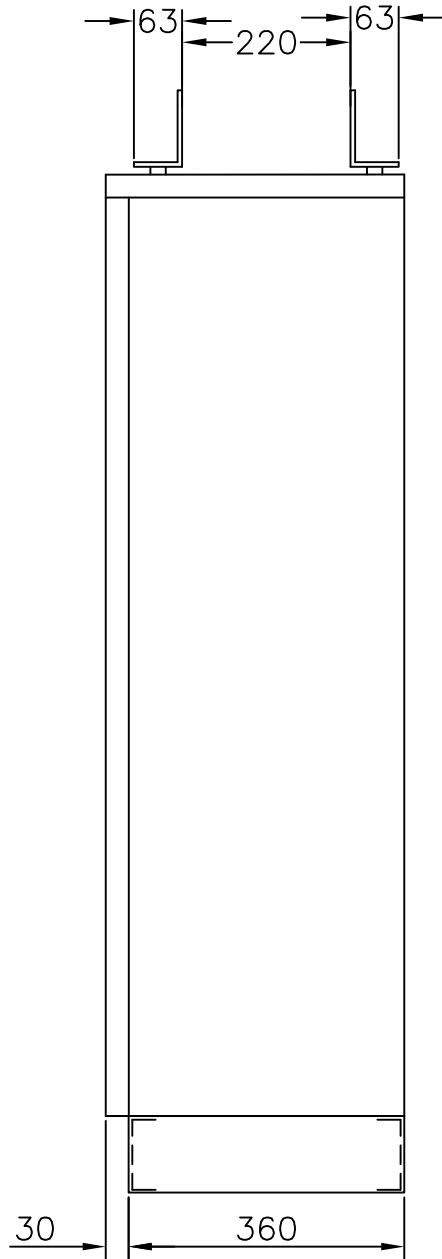

SIDE VIEW

ST: START BUTTON(GREEN)
 SP: STOP BUTTON(RED)
 WL: POWER SOURCE INDICATOR(WHITE)
 GL: RUNNING INDICATOR(GREEN)
 RL: ALARM(RED)
 PROTECTION DEGREE:IP44.
 CABLE ENTRANCE: BOTTOM OPEN

EMERG. FIRE PUMP



OUTLINE VIEW

OVST2

1-38

A B C D E F G H I

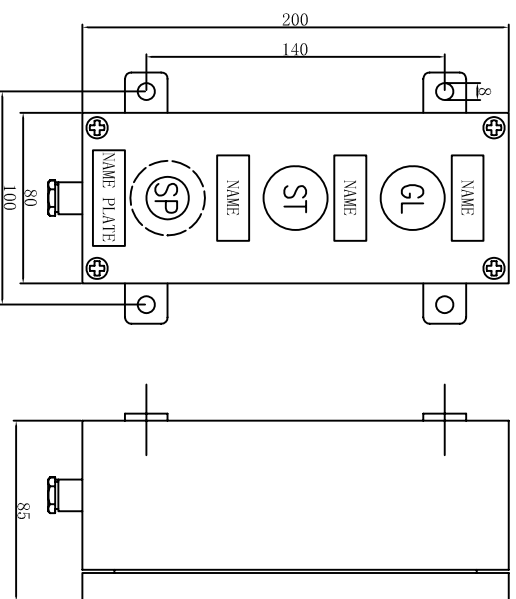

PROTECTION CLASS: IP44
 MATERIAL: GENERAL STEEL
 COLOUR: 7.5RG7/2
 CABLE GLAND: 216
 QT: 33

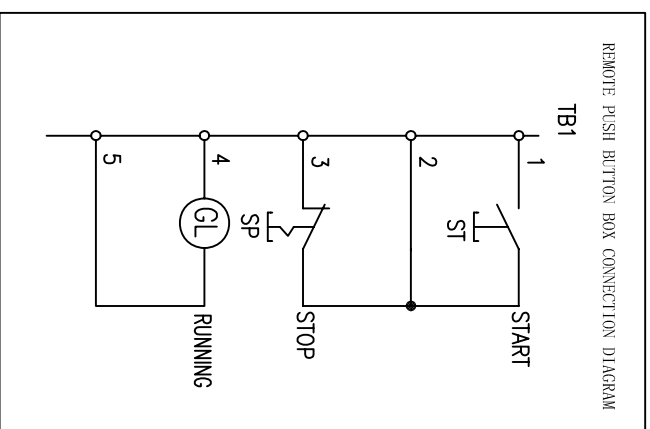

SYMBOL	NAME
GL	RUNNING
ST	START
SP	STOP

NP TYPE	BOX No.	CIR No.	NAME PLATE
U7	PB001	1GSP2	NO.1 L.T. COOLING F.W. PUMP
U7	PB002	1GSP3	NO.1 M/E JACKET C.F.W. PUMP
U7	PB003	1GSP4	NO.1 COOLING S.W.PUMP
U7	PB004	1GSP6	NO.3 COOLING S.W.PUMP
U7	PB005	1GSP7	H.F.O. TRANSFER PUMP
U7	PB006	1GSP8	NO.1 MAIN L.O. PUMP
U7	PB007	1GSP9	NO.1 BALLAST PUMP
U7	PB008	1GSP11	CYL. L.O. TRANSFER PUMP
U7	PB009	1GSP12	DAILY BILGE PUMP
U7	PB010	1GSP13	NO.1 STERN TUBE LUB. OIL PUMP
U7	PB011	1GSP14	L.O. TRANSFER PUMP
U7	PB012	1GSP15	AIR COOLER CHEMICAL CLEANING PUMP
U7	PB013	2GSP2	NO.2 COOLING S.W.PUMP
U7	PB014	2GSP3	NO.2 M/E JACKET C.F.W. PUMP
U7	PB015	2GSP4	NO.2 L.T. COOLING F.W. PUMP
U7	PB016	2GSP5	M/E JACKET W. HEATING PUMP

NP TYPE	BOX No.	CIR No.	NAME PLATE
U7	PB017	2GSP4	NO.3 L.T. COOLING F.W. PUMP
U7	PB018	2GSP7	NO.2 MAIN L.O. PUMP
U7	PB019	2GSP9	SLUDGE PUMP
U7	PB020	2GSP10	NO.2 BALLAST PUMP
U7	PB021	2GSP13	NO.2 STERN TUBE LUB. OIL PUMP
U7	PB022	2GSP14	D.O. TRANSFER PUMP
U7	PB023	405ST3	NO.1 A/C COOLING FW BOOSTER PUMP
U7	PB024	405ST4	NO.2 A/C COOLING FW BOOSTER PUMP
U7	PB025	409ST2	GALLEY SUPPLY FAN
U7	PB026	409ST3	GALLEY EXH. FAN
U7	PB027	409ST6	STEERING GEAR ROOM SUPPLY FAN
U7	PB028	409ST7	CO2 ROOM EXH.FAN
U7	PB029	410ST3	PURIFIER SPACE EXH.FAN
U7	PB030	411ST1	PIPE TUNNEL SUPPLY FAN
U7	PB031	411ST2	BOW THRUSTER & EMERGENCY FIRE PUMP ROOM SUPPLY FAN
U7	PB032	411ST6	AIR LOCK SUPPLY FAN
U7	PB033	411ST7	FORECASTLE CO2 RM EXH.FAN

A B C D E F G H I



LOCAL PUSHBUTTON BOX

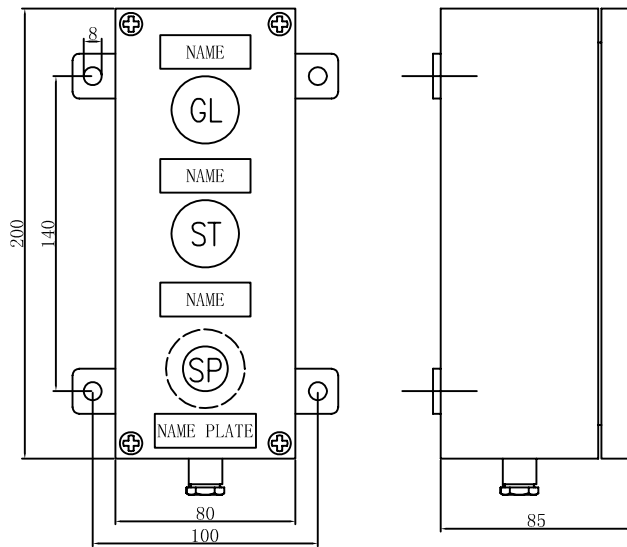

PROTECTION CLASS: IP44
 MATERIAL: GENERAL STEEL
 COLOUR: 7.5BG7/2
 CABLE GLAND: $\varnothing 19$
 QT. :3

REMOTE PUSH BUTTON BOX CONNECTION DIAGRAM

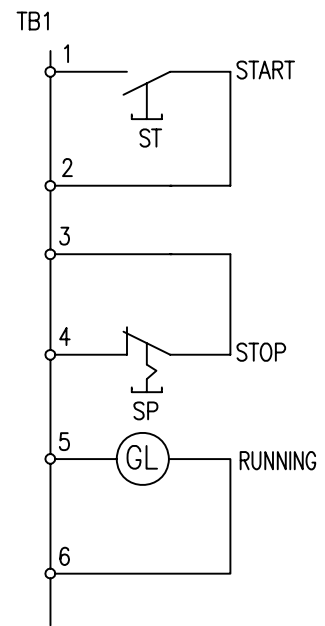

SYMBOL	NAME
GL	RUNNING
ST	START
SP	STOP

NP TYPE	BOX No.	CIR No.	NAME PLATE
U7	PB001	409ST2	GALLEY SUPPLY FAN
U7	PB002	409ST3	GALLEY EXH.FAN
U7	PB003	409ST6	STEERING GEAR ROOM SUPPLY FAN

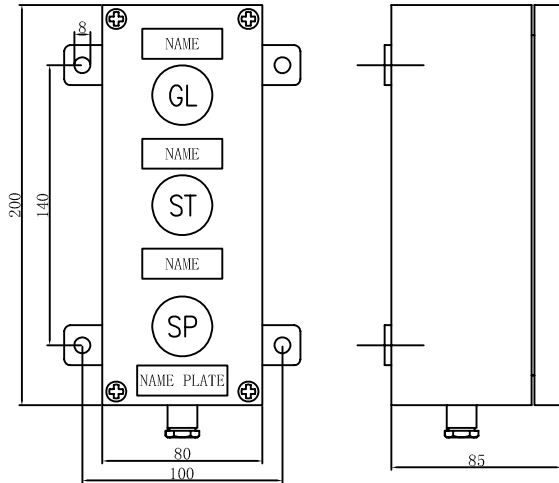

PROTECTION CLASS: IP44
 MATERIAL: GENERAL STEEL
 COLOUR: 7.5BG7/2
 CABLE GLAND: $\varnothing 16$
 QT. :3

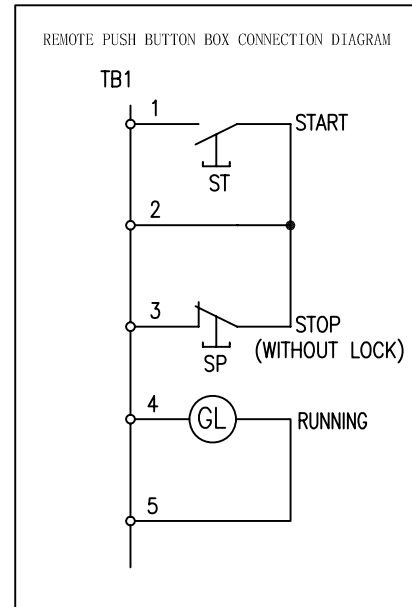

SYMBOL	NAME
GL	RUNNING
ST	START
SP	STOP

NP TYPE	BOX No.	CIR No.	NAME PLATE
U7	PB001	1GSP10	NO.1 FIRE BILGE & G.S. PUMP
U7	PB002	2GSP11	NO.2 FIRE BILGE & G.S. PUMP
U7	PB003	ST2	EMERG. FIRE PUMP

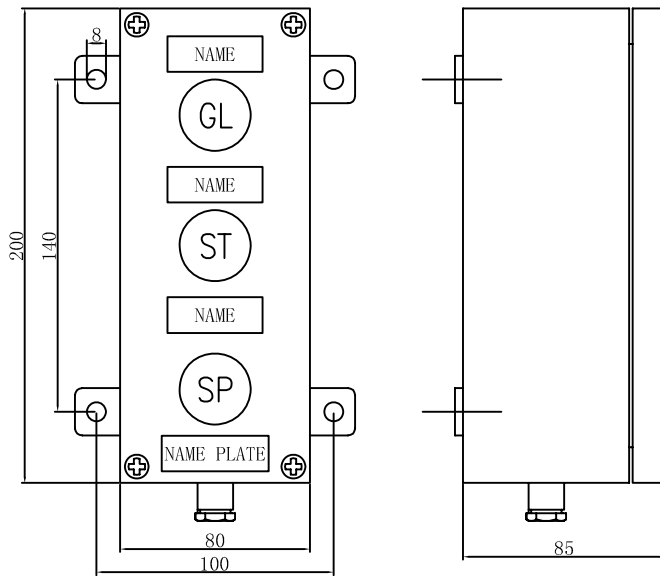

PROTECTION CLASS: IP44
 MATERIAL: GENERAL STEEL
 COLOUR: 7. 5BG7/2
 CABLE GLAND: $\varnothing 19$
 QT. :2

REMOTE PUSH BUTTON BOX CONNECTION DIAGRAM

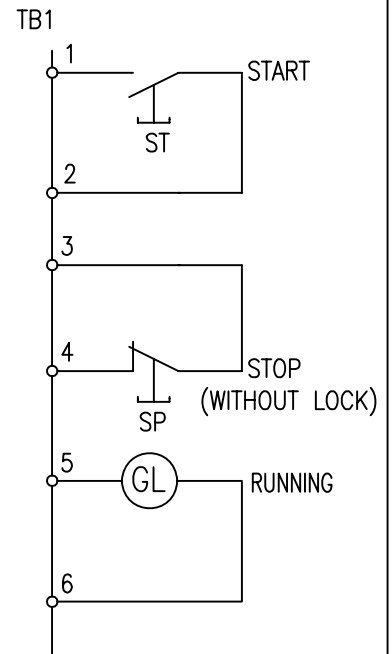

SYMBOL	NAME
GL	RUNNING
ST	START
SP	STOP

NP TYPE	BOX No.	CIR No.	NAME PLATE
U7	PB001	1GSP10	NO.1 FIRE BILGE & G.S. PUMP
U7	PB002	2GSP11	NO.2 FIRE BILGE & G.S. PUMP

OUTLINE VIEW

EMERGENCY STOP REMOTE PB

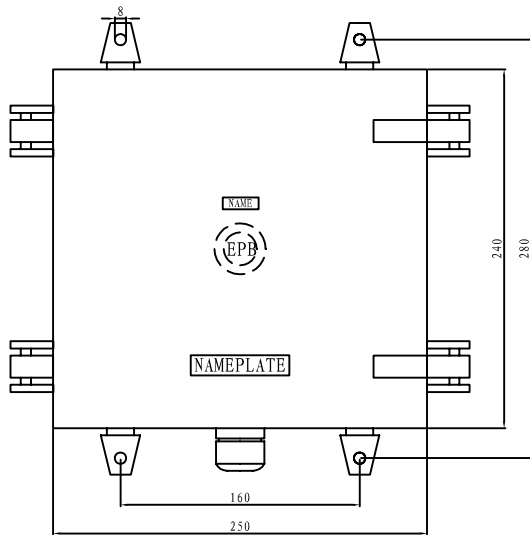

FROM VIEW

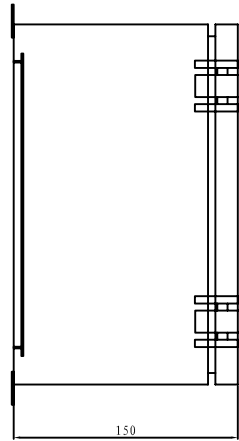

SIDE VIEW

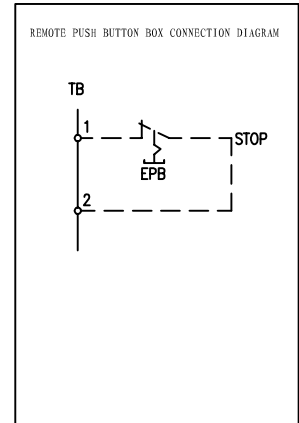

PROTECTION CLASS: IP56
 MATERIAL: STAINLESS STEEL
 COLOUR: 7. 5BG7/2
 CABLE GLANDS: ϕ 13
 QT. : 9

SYMBOL	NAME
EPB	EMERGENCY STOP

NP TYPE	BOX No.	POS1	CIR No.	NAME PLATE
U7	PB009 PB010	NP		OILY WATER SEPARATOR
U7	PB011	NP		M/E NO. 1 FEEDER PUMP
U7	PB012	NP		M/E NO. 2 FEEDER PUMP
U7	PB013	NP		M/E CONTROL PANEL
U7	PB014	NP		A/E NO. 1 FEEDER PUMP
U7	PB015	NP		A/E NO. 2 FEEDER PUMP
U7	PB016	NP		A/E CONTROL PANEL
U7	PB017	NP		MDO PUMP

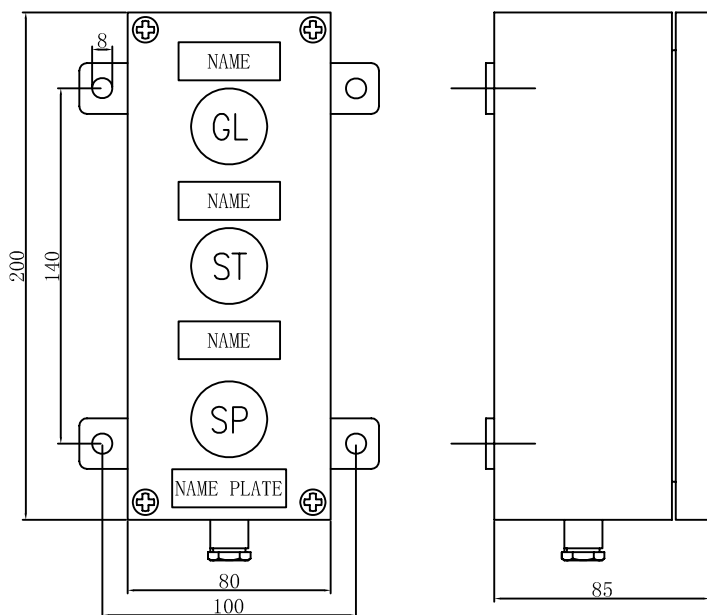

PROTECTION CLASS: IP44
 MATERIAL: GENERAL STEEL
 COLOUR: 7.5BG7/2
 CABLE GLAND: $\varnothing 15.3$
 QT. :2

SYMBOL	NAME
GL	RUNNING
ST	START
SP	STOP

REMOTE PUSH BUTTON BOX CONNECTION DIAGRAM

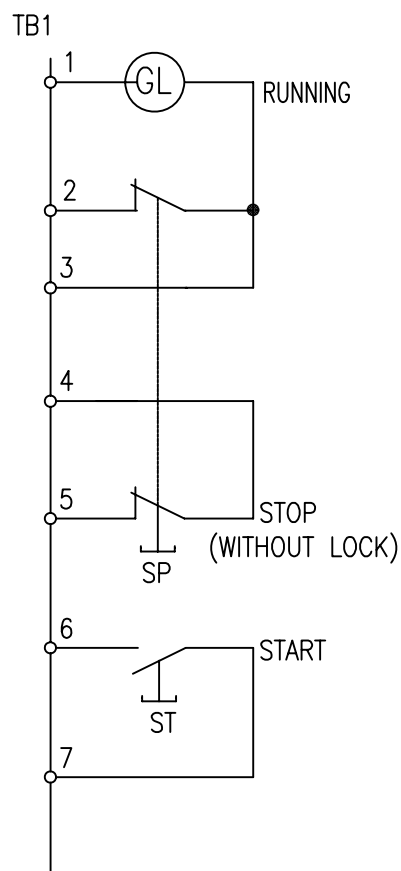

NP TYPE	BOX No.	NAME PLATE
U7	PB200	NO.1 FEED WATER PUMP PUSH BUTTON FOR BOILER
U7	PB201	NO.2 FEED WATER PUMP PUSH BUTTON FOR BOILER

OUTLINE VIEW

EMERGENCY STOP REMOTE PB

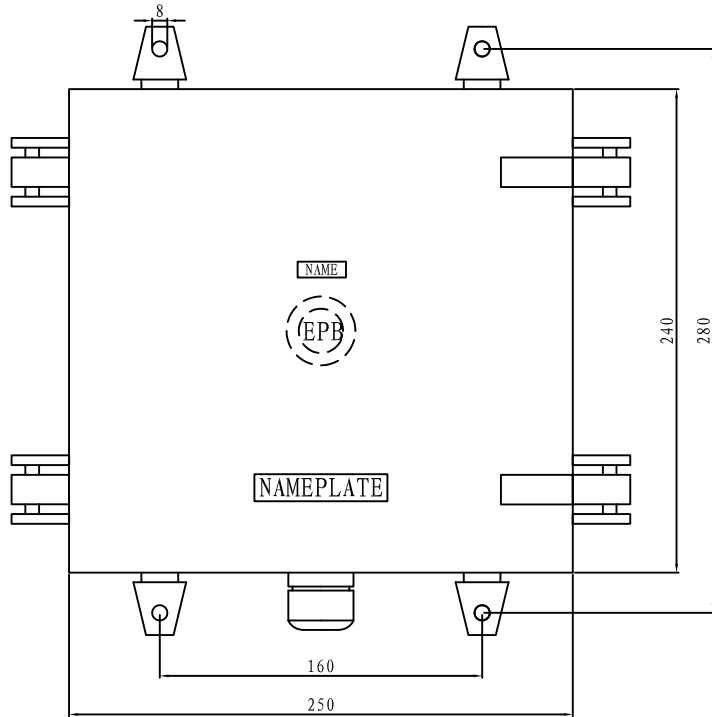

FROM VIEW

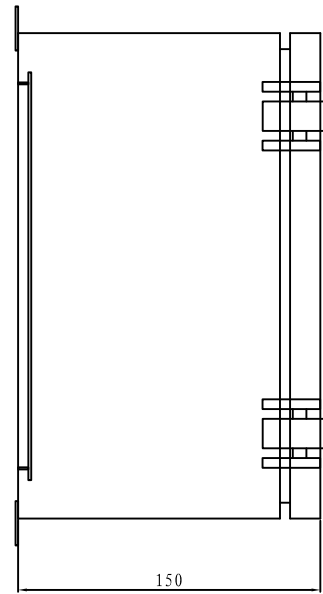

SIDE VIEW

PROTECTION CLASS: IP56

MATERIAL: STAINLESS STEEL

COLOUR: 7. 5BG7/2

CABLE GLANDS: ϕ 16

QT. : 2

REMOTE PUSH BUTTON BOX CONNECTION DIAGRAM FOR EM, CY STOP PB FOR BALLAST & G. S. PUMPS OF DIS. TO OVBD

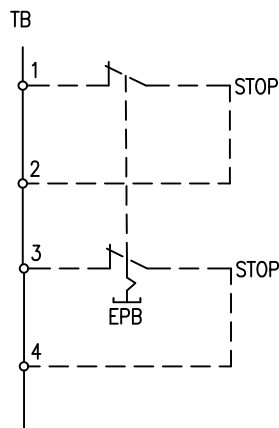

REMOTE PUSH BUTTON BOX CONNECTION DIAGRAM FOR EM, CY STOP PB FOR BALLAST & G. S. PUMPS & C. S. W. PUMP. OF DIS. TO OVBD

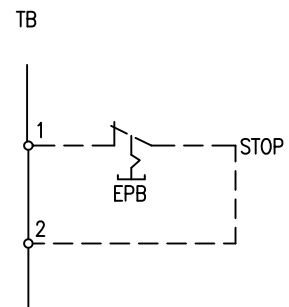











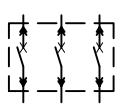
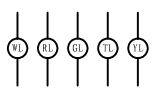
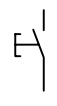
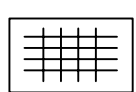

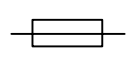
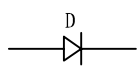

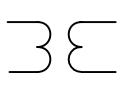

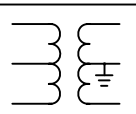

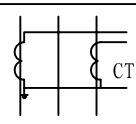
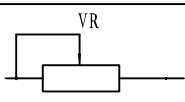

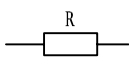

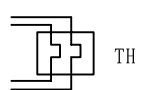









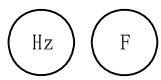

SYMBOL	NAME
EPB	EMERGENCY STOP

NP TYPE	BOX No.	POSI	CIR No.	NAME PLATE
U7	PB020	NP		EM' CY STOP PB FOR BALLAST & G. S. PUMPS OF DIS. TO OVBD
U7	PB021	NP		EM' CY STOP PB FOR BALLAST & G. S. PUMPS & C. S. W. PUMP. OF DIS. TO OVBD

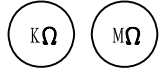
VOL.2

GRAPHICAL SYMBOL	GS
CONNECTION DIAGRAM OF PLC	PLC
CONTROL SCHEMATIC DRAWING	SA

GRAPHIC CODE

LEGEND	NAME	LEGEND	NAME	LEGEND	NAME
	ACB, MCCB		INDICATING LAMP		PUSH BUTTON OPEN CONTACT
	CHANGEOVER SWITCH		FLUORESCENT LAMP		PUSH BUTTON CLOSE CONTACT
	FUSE		DIODE		EARTH CONNECTION
	TRANSFORMER		GENERATOR		CHANGEOVER SWITCH OPEN CONTACT
	VOLTAGE TRANSFORMER		GOVERNOR MOTOR		POWER OFF TIMER RELAY OPEN CONTACT
	CURRENT TRANSFORMER		VARIABLE RESISTOR		NORMALLY OPEN CONTACT
	TIMER RELAY		RESISTOR		NORMALLY CLOSE CONTACT
	THERMAL		SHUNT		TIMER RELAY NORMALLY OPEN CONTACT
	PHASE SEQUENCE RELAY		SYNCHROSCOPE		TIMER RELAY NORMALLY CLOSE CONTACT
	POWER OFF TIMER RELAY		VOLTMETER		CHANGEOVER SWITCH CLOSE CONTACT
	REVERSE POWER RELAY		AMMETER		POWER OFF TIMER RELAY CLOSE CONTACT
	STATOR WINDING MONITOR		FREQUENCY METER		
	CONTACTOR & RELAY		POWER FACTOR METER		
	POWER TRANSDUCER		INSULATION RESISTANCE METER		
	RUNNING HOUR METER		KILOWATT METER		
	UNDER VOLTAGE TRIP		KILOWATT HOUR METER		
	SHUNT TRIP				

NO. 1 GSP → → NO. 2 GSP

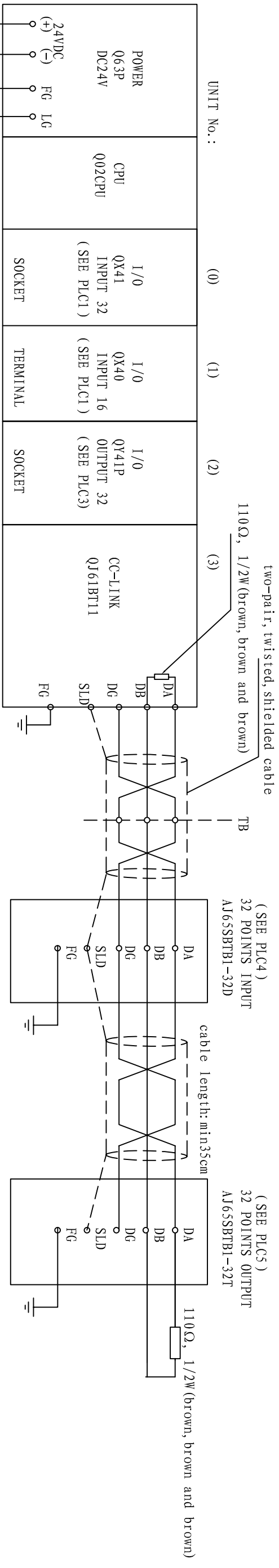

QJ61BT11 SETTING:

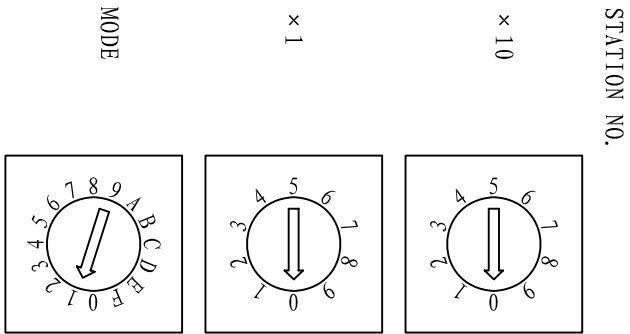

REFER TO OPERATION MANUAL

AJ65SBTB1-32D HARDWARE SETTING:

AJ65SBTB1-32T HARDWARE SETTING:

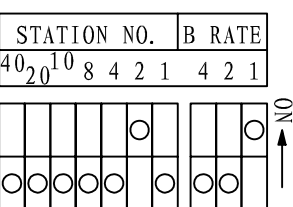
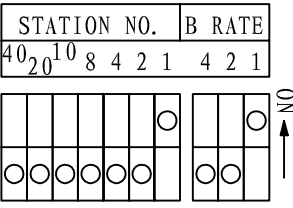

NO. 2 GSP

A	B	C	D	E	F	G	H	I
---	---	---	---	---	---	---	---	---



CONTROL SYSTEM ASSIGNMENT

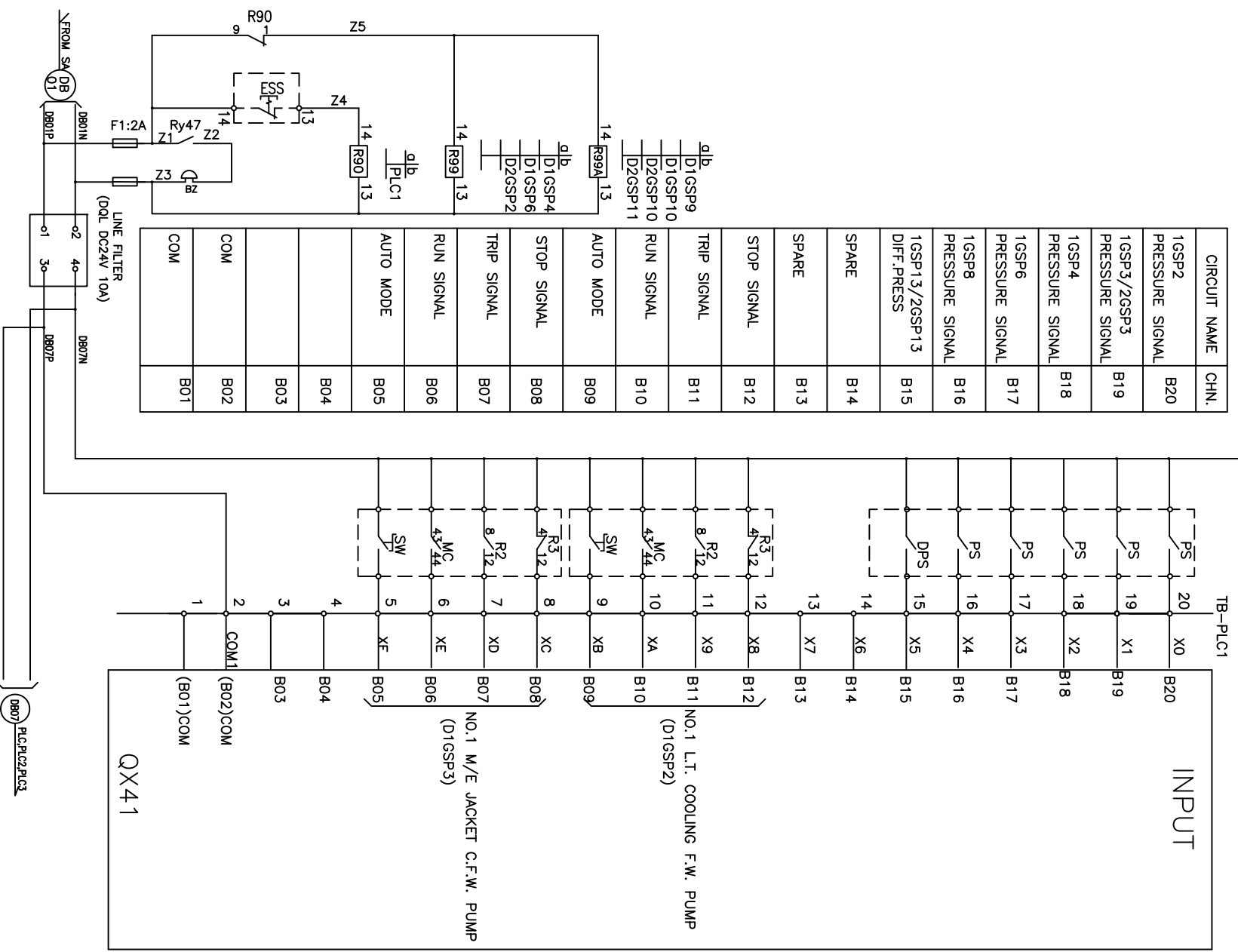

CIRCUIT NAME	CHN.
1GSP2 PRESSURE SIGNAL	B20
1GSP3/2GSP3 PRESSURE SIGNAL	B19
1GSP4 PRESSURE SIGNAL	B18
1GSP6 PRESSURE SIGNAL	B17
1GSP8 PRESSURE SIGNAL	B16
1GSP13/2GSP13 DIFF.PRESS	B15
SPARE	B14
SPARE	B13
STOP SIGNAL	B12
TRIP SIGNAL	B11
RUN SIGNAL	B10
AUTO MODE	B09
STOP SIGNAL	B08
TRIP SIGNAL	B07
RUN SIGNAL	B06
AUTO MODE	B05
COM	B02
COM	B01

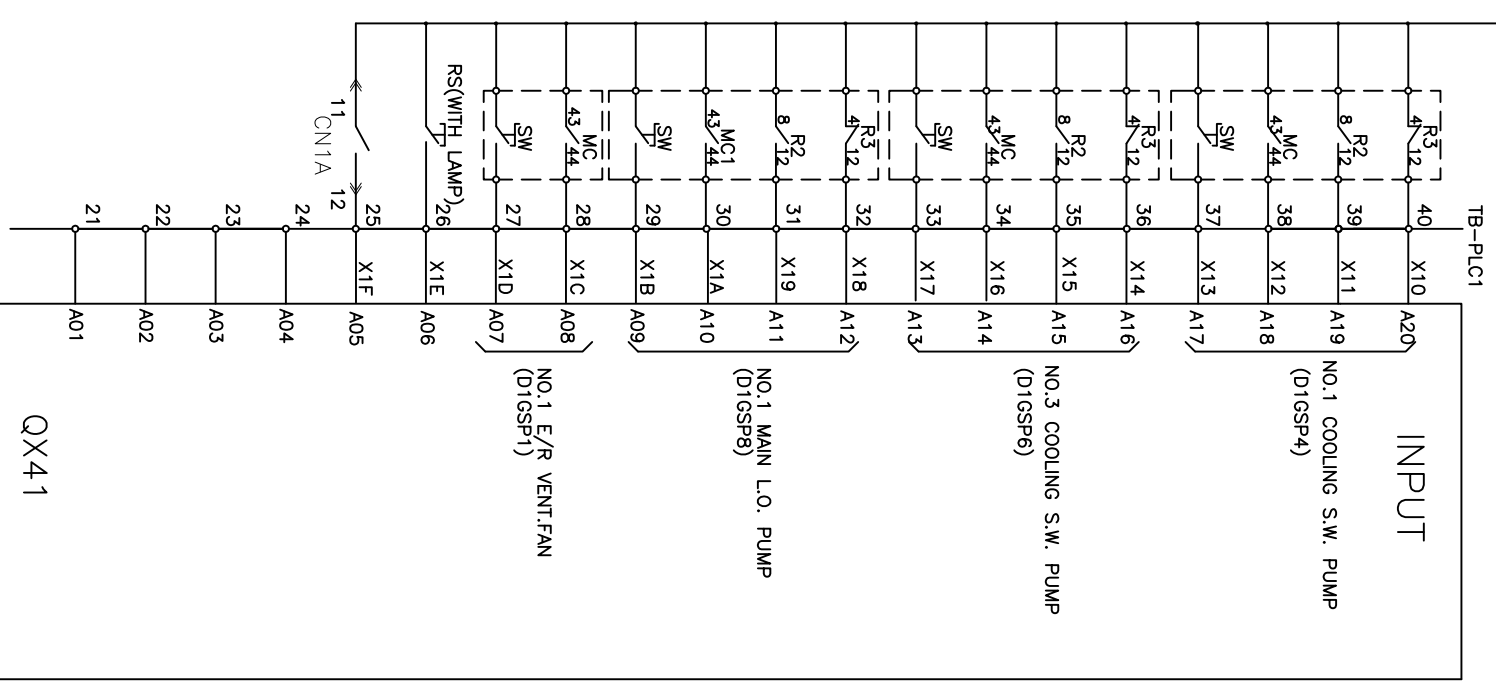

CIRCUIT NAME	CHN.
STOP SIGNAL	A20
TRIP SIGNAL	A19
RUN SIGNAL	A18
AUTO MODE	A17
STOP SIGNAL	A16
TRIP SIGNAL	A15
RUN SIGNAL	A14
AUTO MODE	A13
STOP SIGNAL	A12
TRIP SIGNAL	A11
RUN SIGNAL	A10
AUTO MODE	A09
RUN SIGNAL	A08
AUTO MODE	A07
RESET	A06
BUSBAR POWER AVAILABLE	A05
	A04
	A03
	A02
	A01

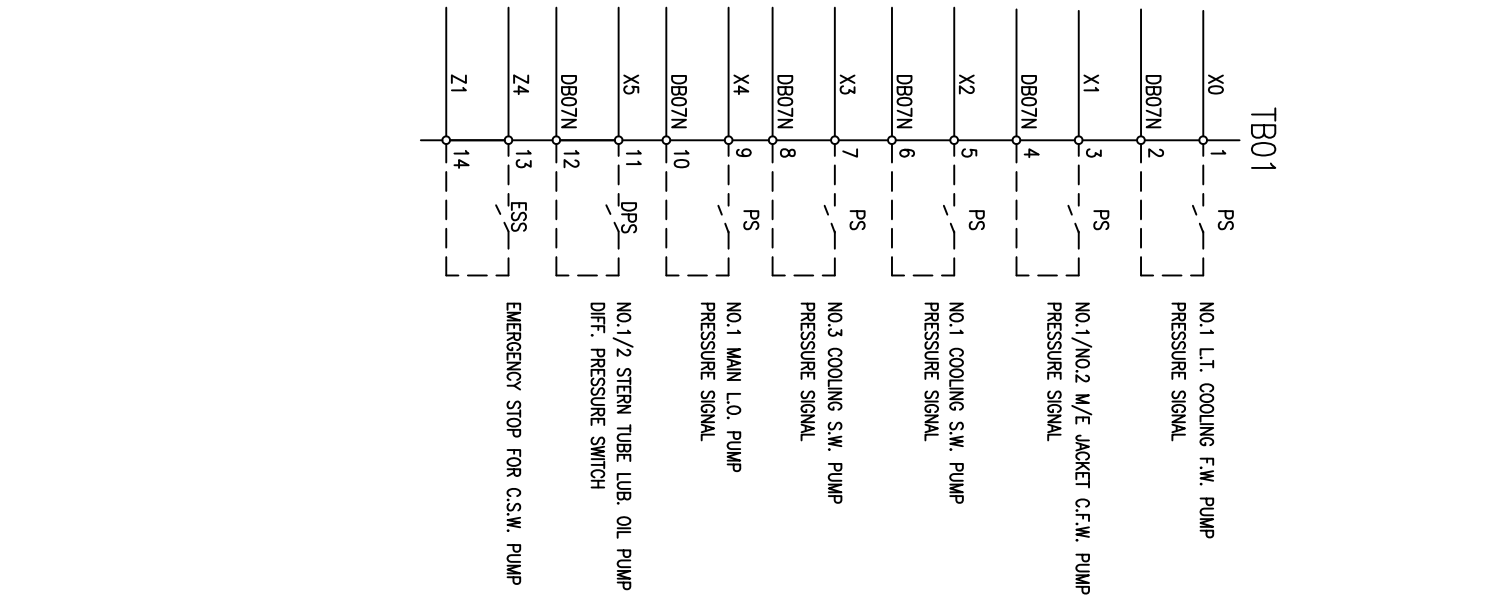

CIRCUIT NAME	CHN.
STOP SIGNAL	A12
TRIP SIGNAL	A11
RUN SIGNAL	A10
AUTO MODE	A09
RUN SIGNAL	A08
AUTO MODE	A07
RESET	A06
BUSBAR POWER AVAILABLE	A05
	A04
	A03
	A02
	A01



CIRCUIT NAME	CHN.
RUN SIGNAL (SUPPLY)	TB1
RUN SIGNAL (EXHAUST)	TB2
AUTO SIGNAL	TB3
STOP SIGNAL	TB4
TRIP SIGNAL	TB5
RUN SIGNAL	TB6
AUTO MODE	TB7
SPARE	TB8
SPARE	TB9
SPARE	TB10
SPARE	TB11
SPARE	TB12
SPARE	TB13
SPARE	TB14
SPARE	TB15
SPARE	TB16
	TB17
	TB18

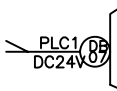
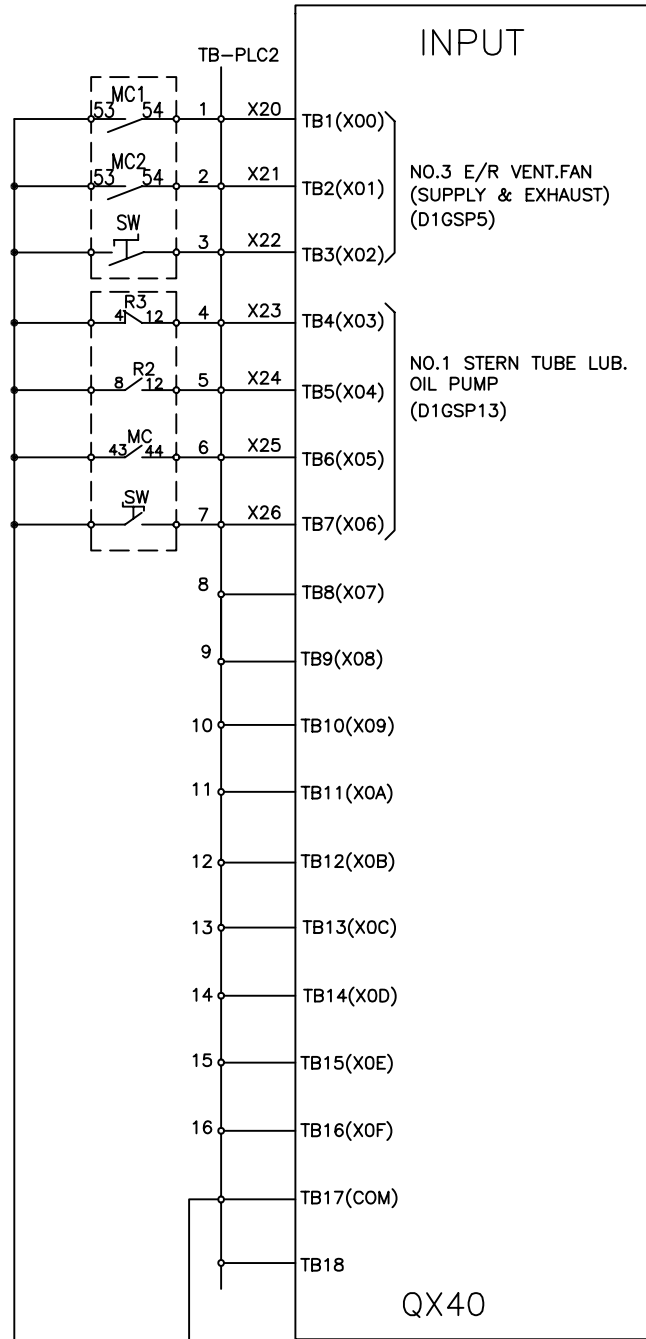

CIRCUIT NAME	CHN.
STANDBY	1B20
STANDBY	1B19
STANDBY	1B18
STANDBY	1B17
STANDBY	1B16
START	1B15
STOP	1B14
START	1B13
STOP	1B12
START	1B11
STOP	1B10
START	1B09
STOP	1B08
START	1B07
STOP	1B06
RESET LAMP	1B05
	1B04
	1B03
DC24V POWER	1B02
DC24V POWER	1B01

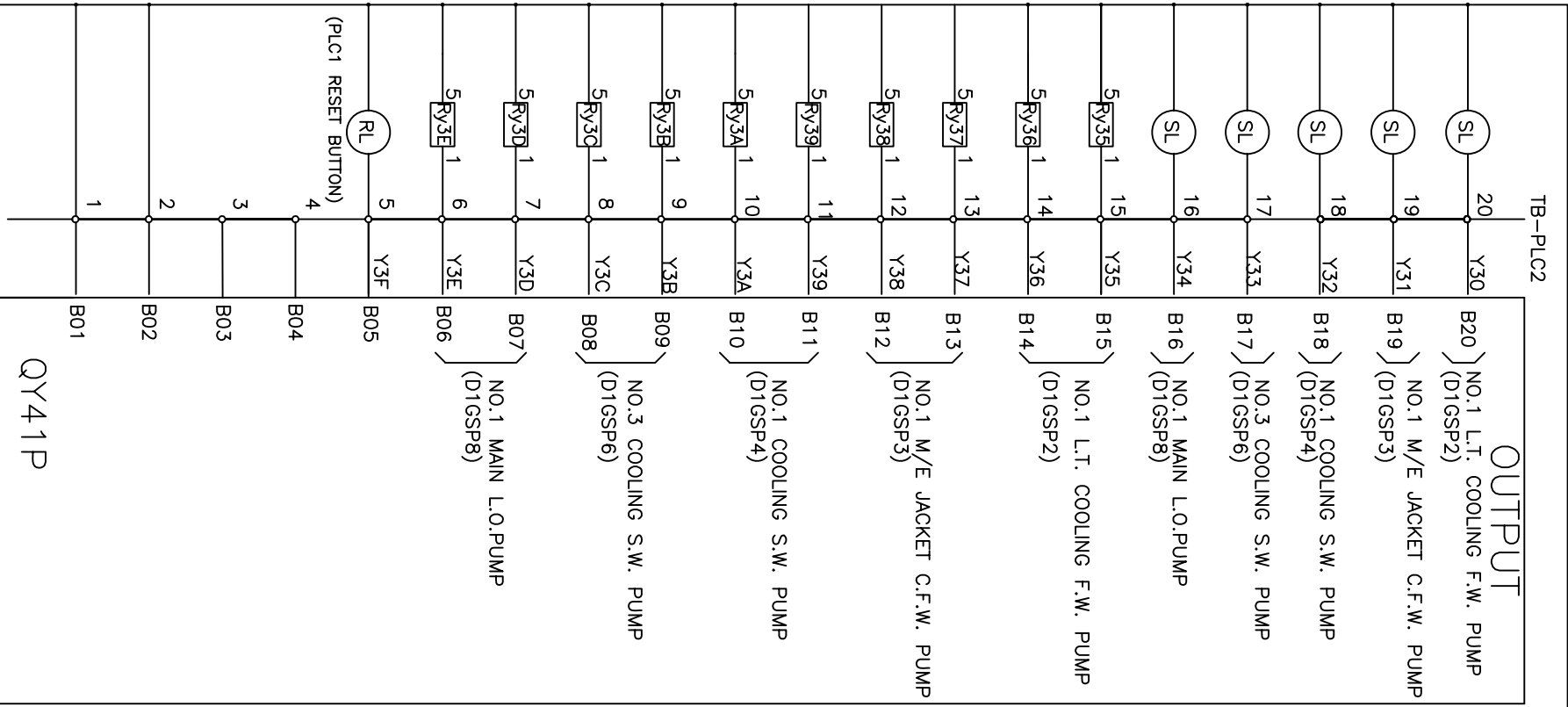

CIRCUIT NAME	CHR.
START	1A20
SUPPLY START	1A19
EXHAUST START	1A18
ACO ALARM	1A17
ACO ALARM	1A16
ACO ALARM	1A15
ACO ALARM	1A14
BUZZER	1A13
2GSP5 RUN SIGNAL TO 1GSP3	1A12
START	1A11
STOP	1A10
STANDBY	1A09
ACO ALARM	1A08
SPARE	1A07
SPARE	1A06
SPARE	1A05
COM	1A04
COM	1A03
COM	1A02
COM	1A01

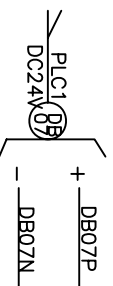
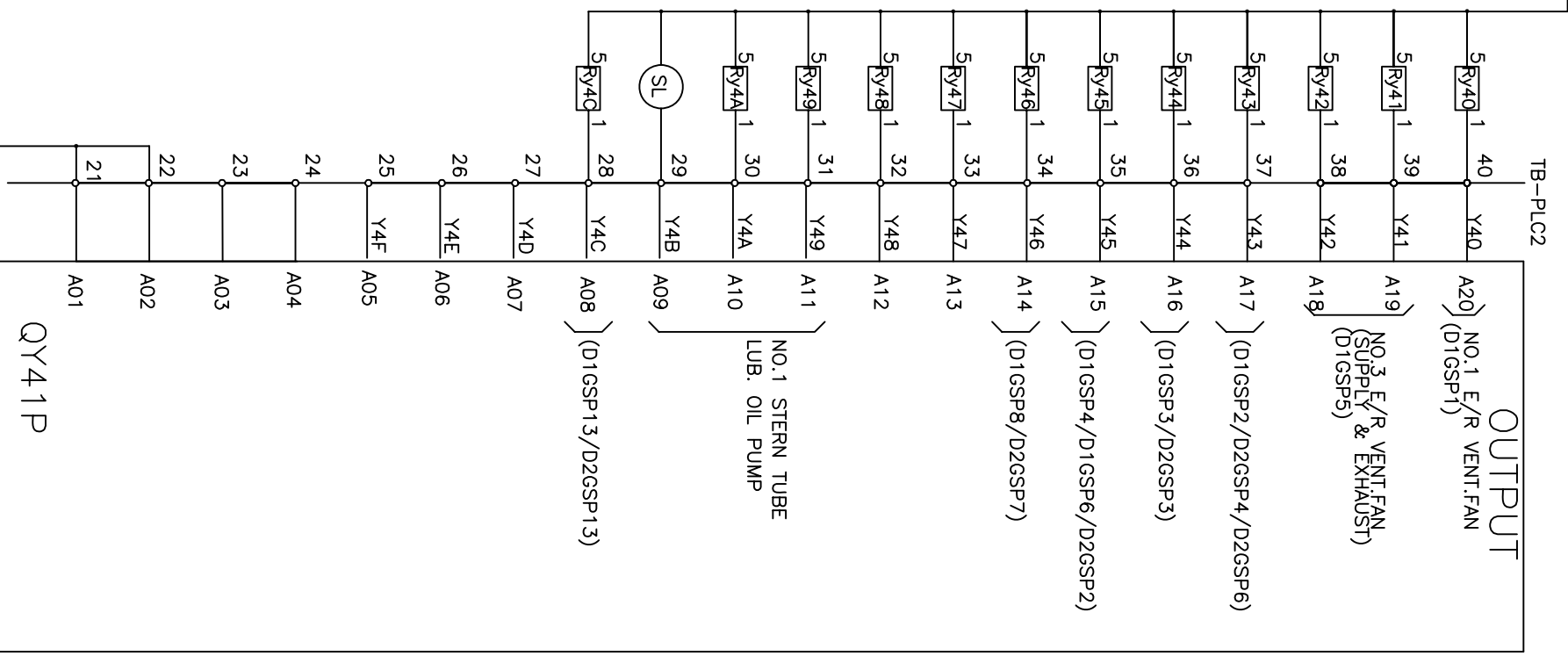

A B C D E F G H I



PLC CIRCUIT 2-5

NO.1 GSP

CIRCUIT NAME	CHN.
RUN SIGNAL	XC
STOP SIGNAL	XB
TRIP SIGNAL	XA
RUN SIGNAL	X9
AUTO SIGNAL	X8
STOP SIGNAL	X7
TRIP SIGNAL	X6
RUN SIGNAL	X5
AUTO SIGNAL	X4
STOP SIGNAL	X3
TRIP SIGNAL	X2
RUN SIGNAL	X1
AUTO SIGNAL	X0
COMMON	COM
COMMON	COM
COMMON	COM
DC24V POWER	0V
DC24V POWER	24V

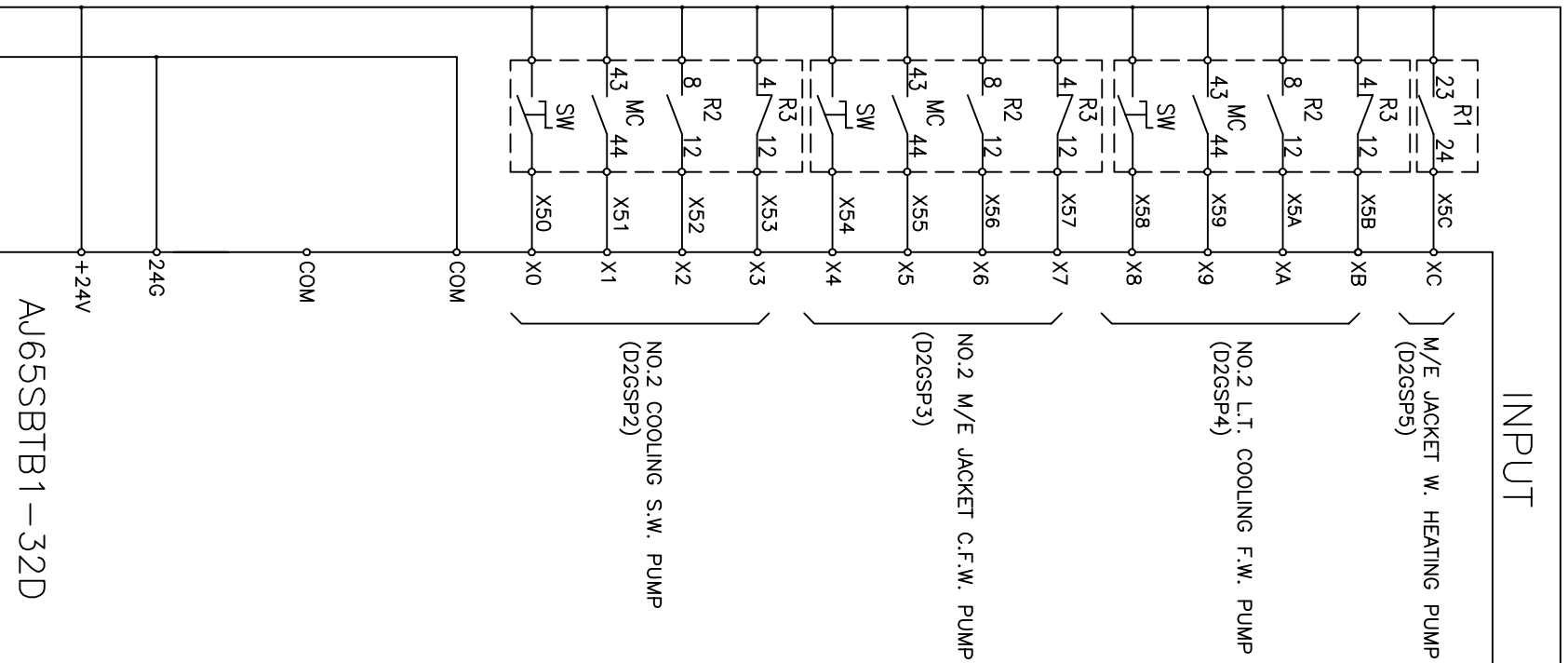
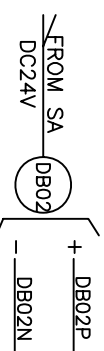

CIRCUIT NAME	CHN.
SPARE	X1E
STOP SIGNAL	X1D
TRIP SIGNAL	X1C
RUN SIGNAL	X1B
AUTO SIGNAL	X1A
2GSP6 PRESSURE SIGNAL	X19
2GSP4 PRESSURE SIGNAL	X18
2GSP2 PRESSURE SIGNAL	X17
RUN SIGNAL	X16
AUTO SIGNAL	X15
STOP SIGNAL	X14
TRIP SIGNAL	X13
RUN SIGNAL	X12
AUTO SIGNAL	X11
STOP SIGNAL	X10
TRIP SIGNAL	XF
RUN SIGNAL	XE
AUTO SIGNAL	XD

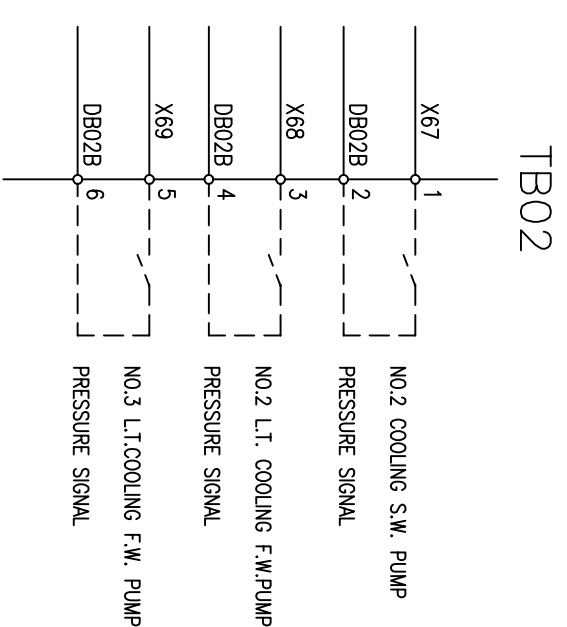
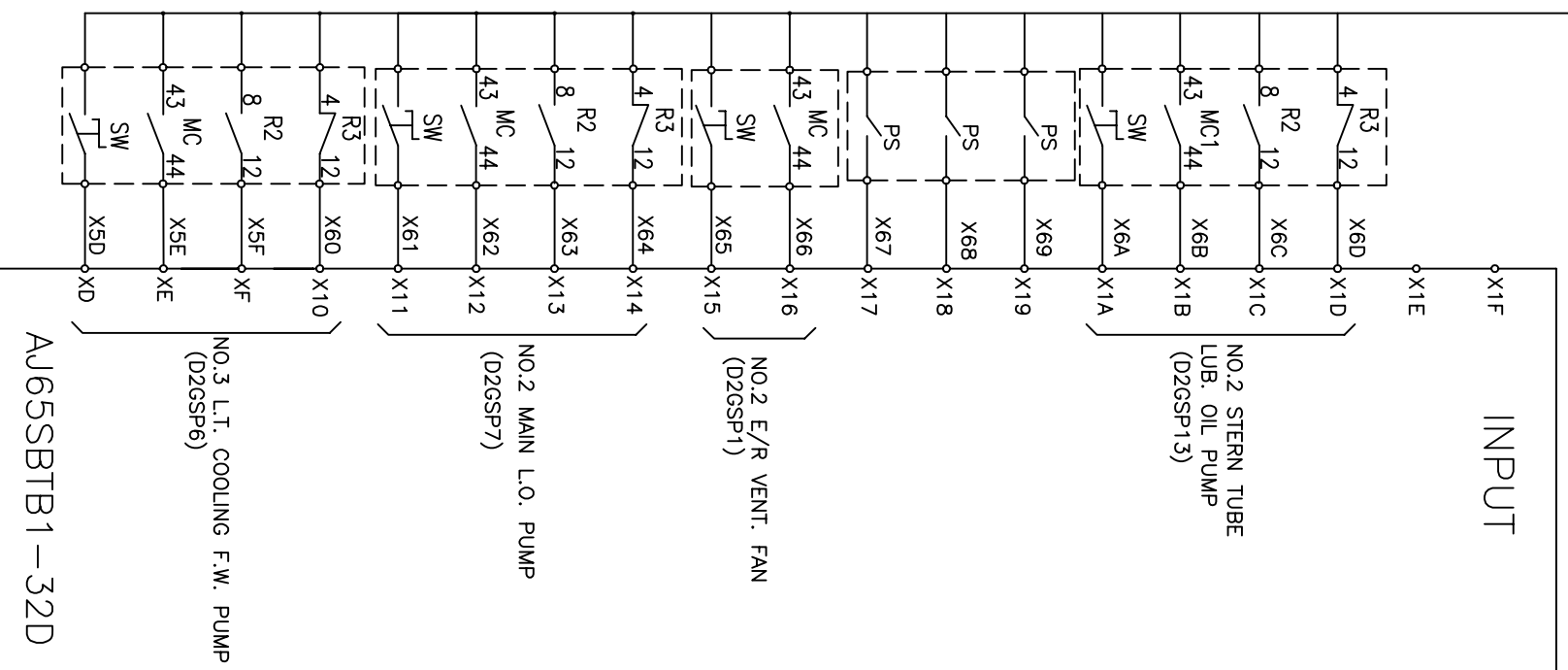

A B C D E F G H I



No.2 GSP CIRCUIT(A)

PLC4
2-6

CIRCUIT NAME	CHN.
1GSP3 RUN SIGNAL TO 2GSP5	YD
STOP	YC
START	YB
STOP	YA
START	Y9
STOP	Y8
START	Y7
STOP	Y6
START	Y5
STANDBY	Y4
STANDBY	Y3
STANDBY	Y2
STANDBY	Y1
STANDBY	Y0
DC24V POWER	24V

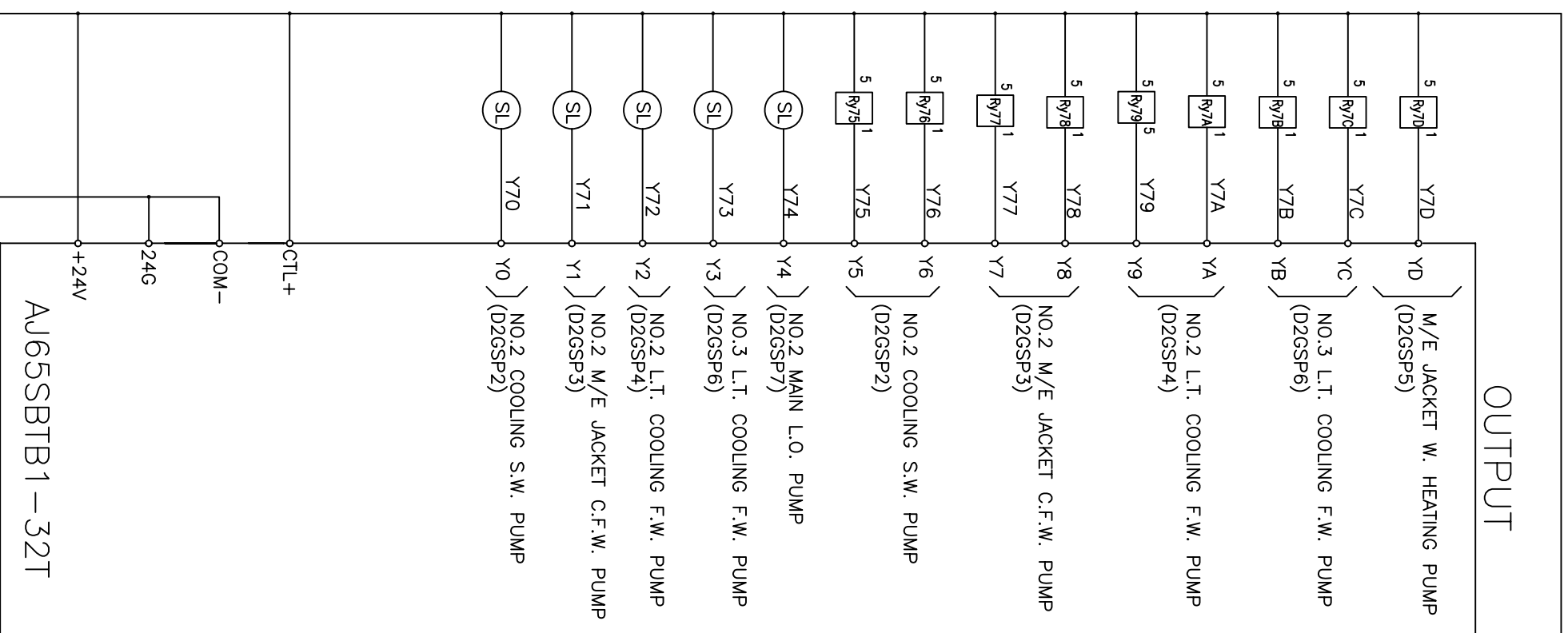

CIRCUIT NAME	CHR.
SPARE	Y1F
SPARE	Y1E
SPARE	Y1D
SPARE	Y1C
SPARE	Y1B
SPARE	Y1A
SPARE	Y19
SPARE	Y18
SPARE	Y17
SPARE	Y16
SPARE	Y15
SPARE	Y14
STANDBY	Y13
STOP	Y12
START	Y11
START	Y10
STOP	YF
START	YE

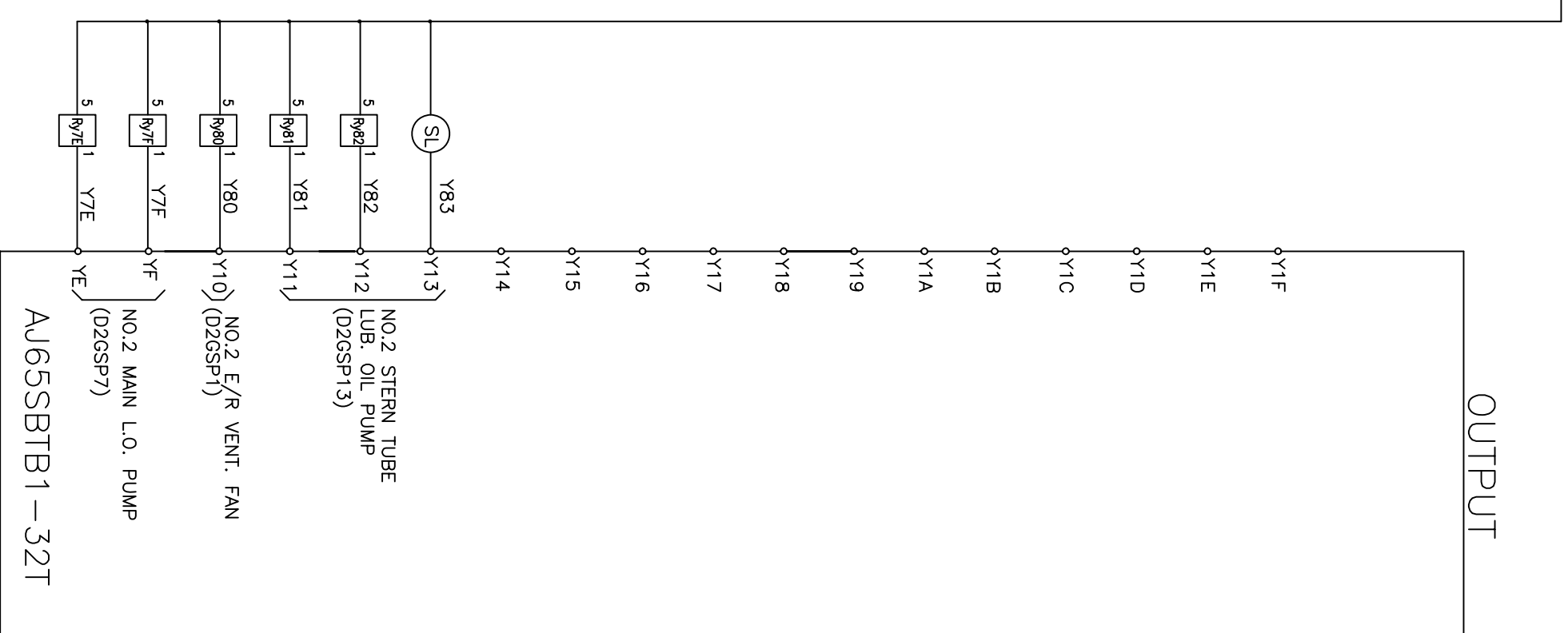

A B C D E F G H I I



No.2 GSP CIRCUIT(B)

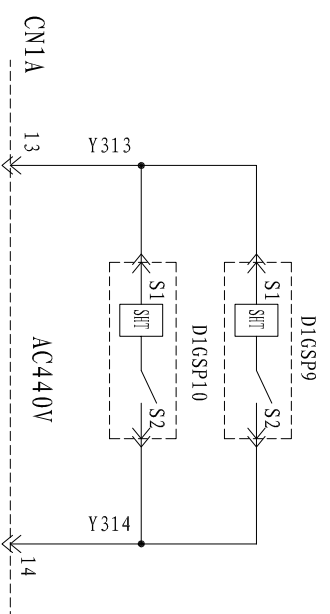

(MSB) (NO. 1 GSP) (ES)

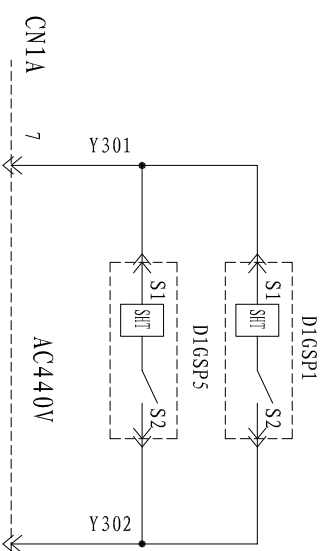

(MSB) (NO. 1 GSP) (ES1)

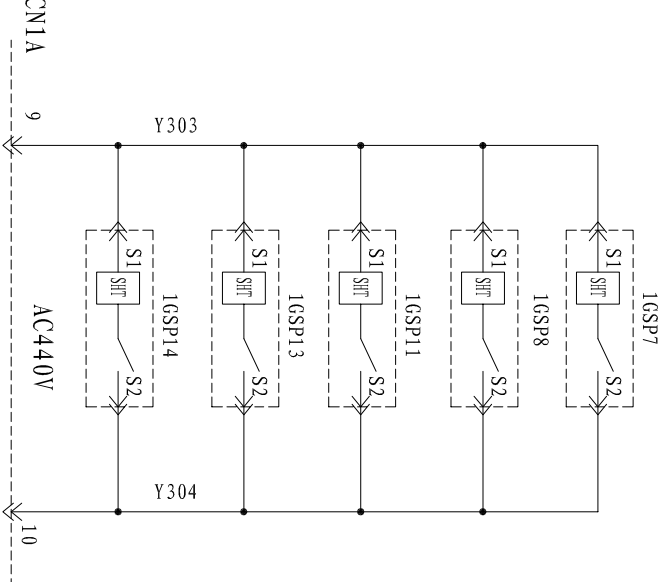

(MSB) (NO. 1 GSP) (ES2)

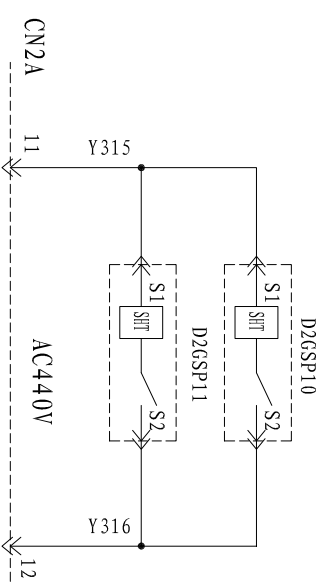

(MSB) (NO. 2 GSP) (ES)

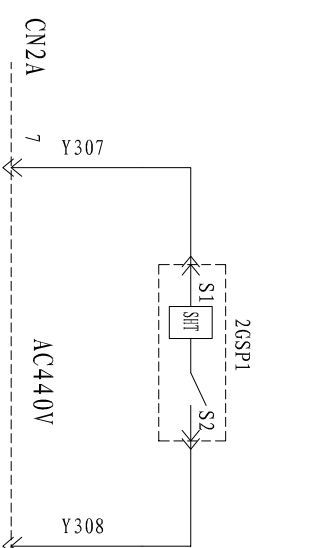

(MSB) (NO. 2 GSP) (ES1)

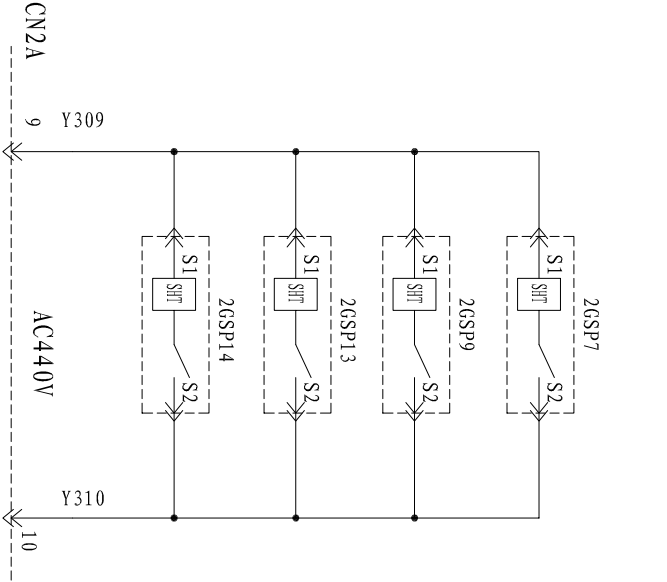

(MSB) (NO. 2 GSP) (ES2)

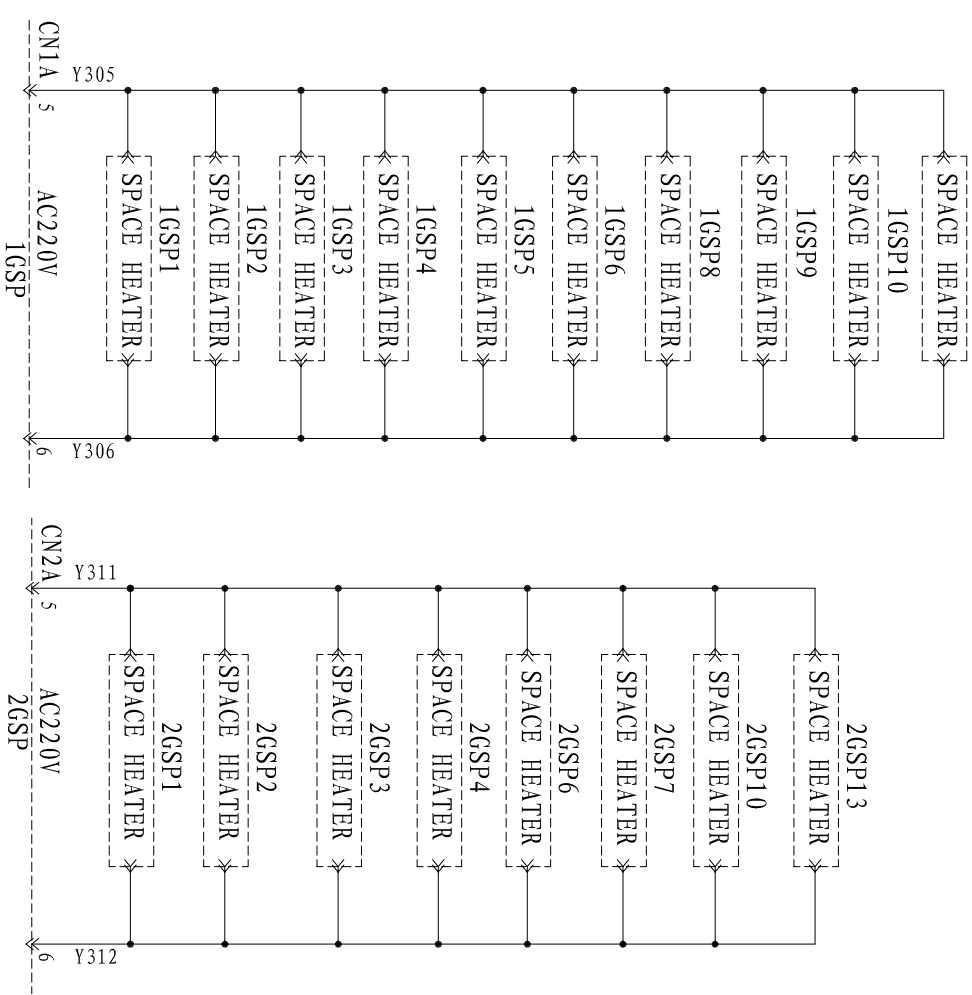
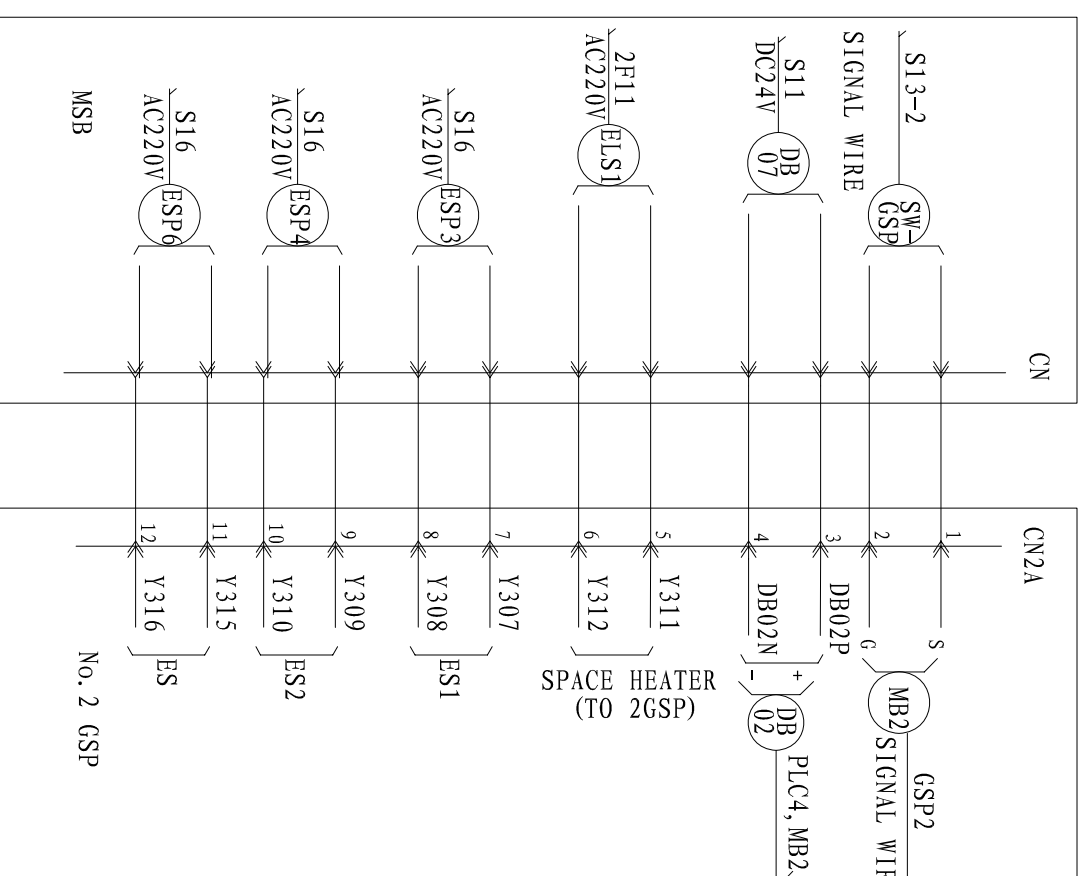
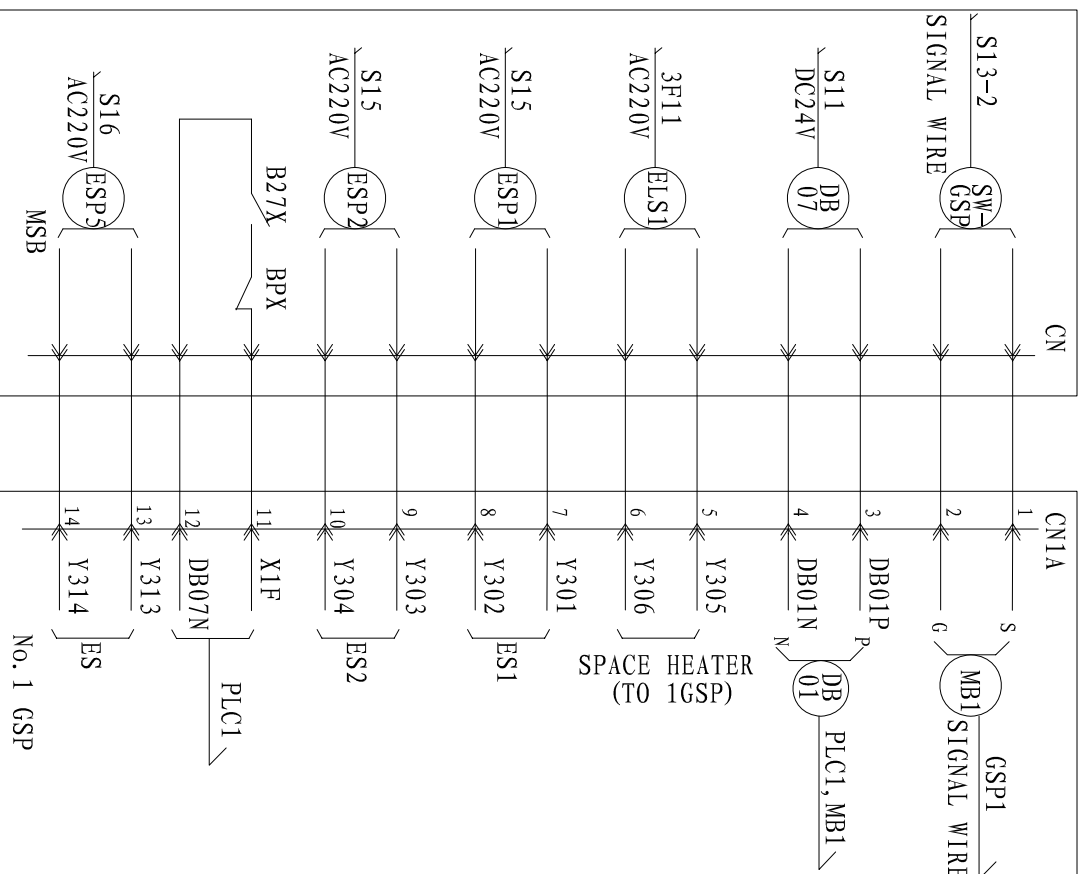

A	B	C	D	E	F	G	H	I
---	---	---	---	---	---	---	---	---



SCHEMATIC DIAGRAM

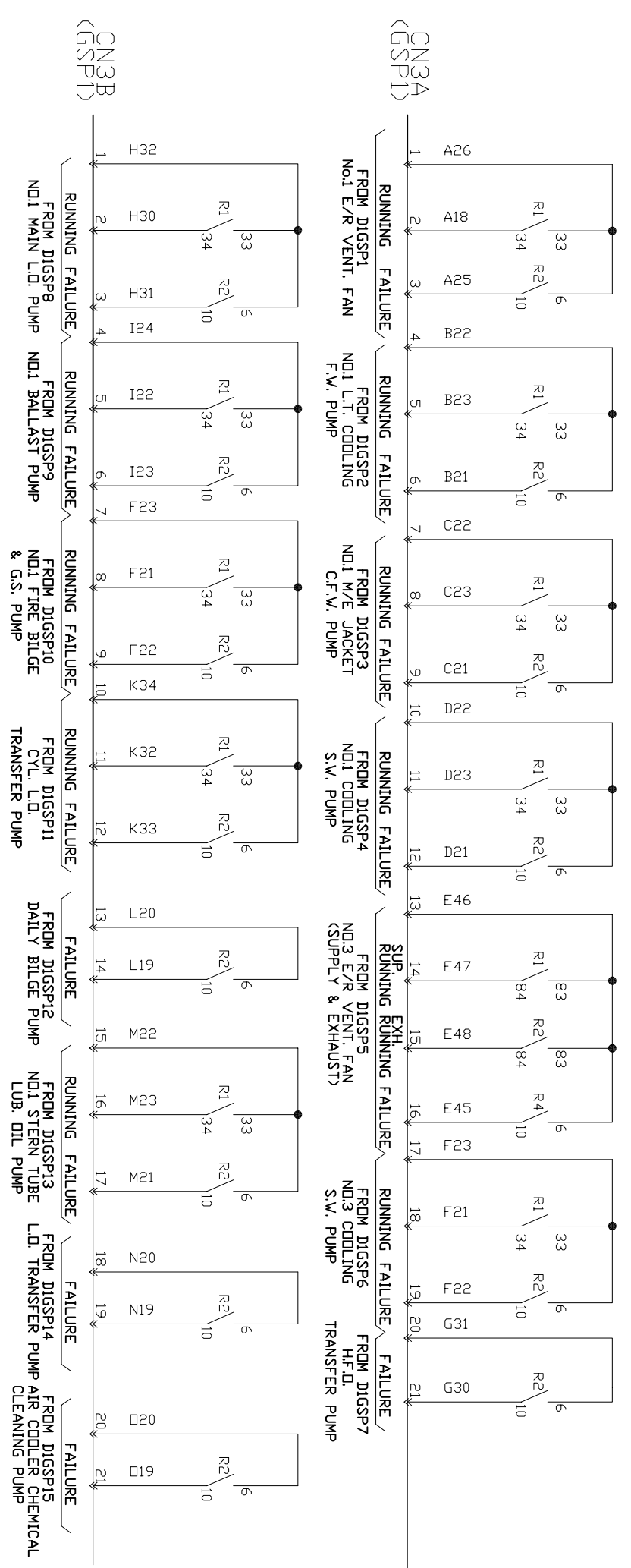
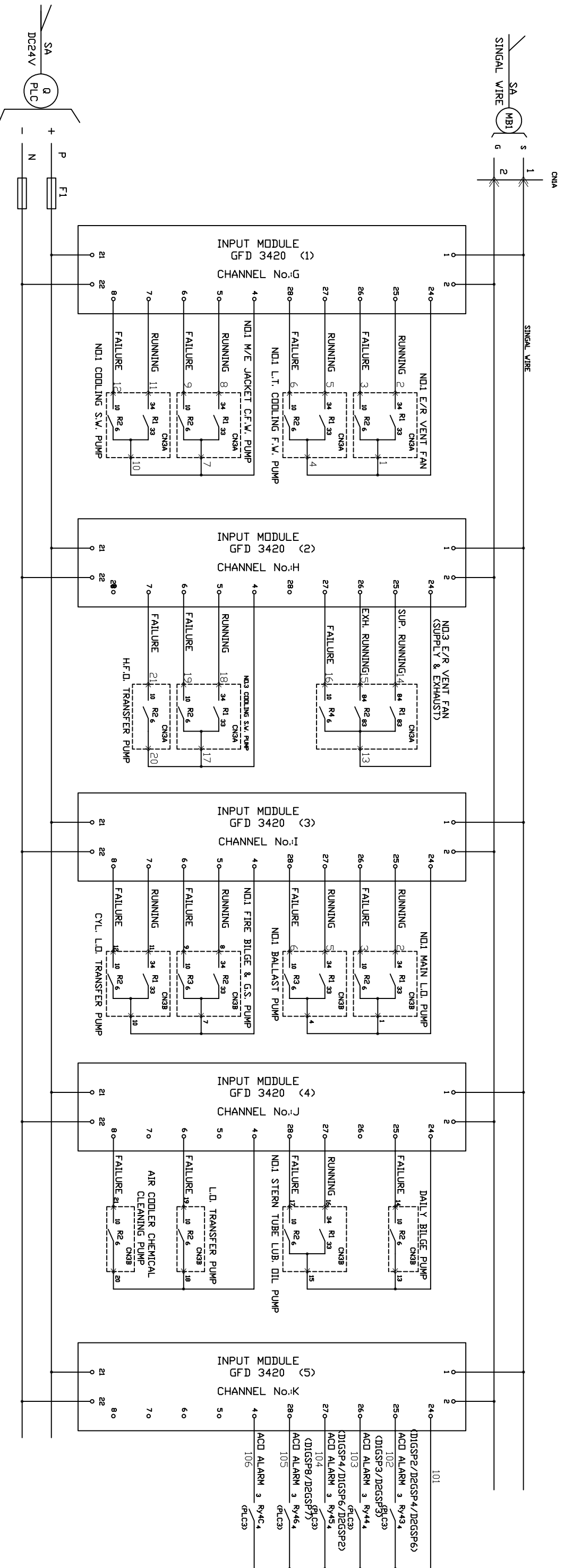

A	B	C	D	E	F	G	H	I	MB1
ND1 GROUP STARTER PANEL									2-9



ND1 GROUP STARTER PANEL
MODBUS CIRCUIT

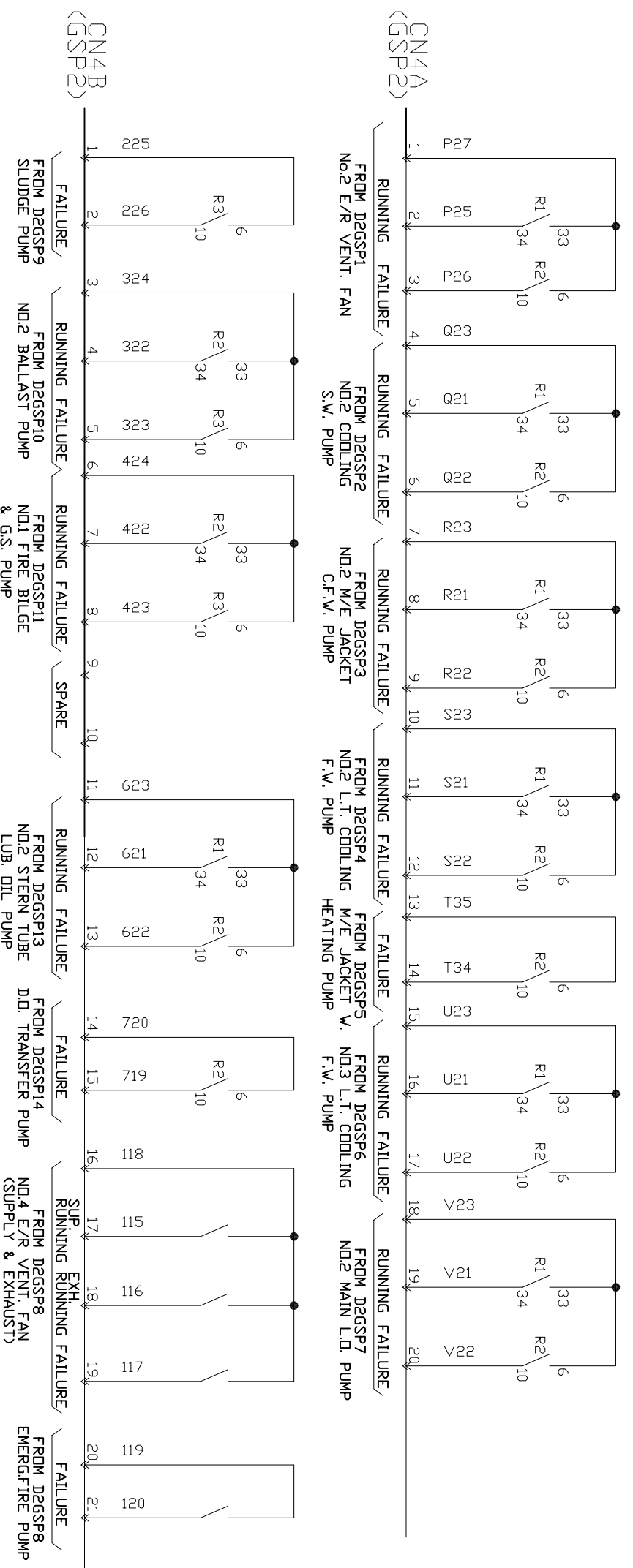
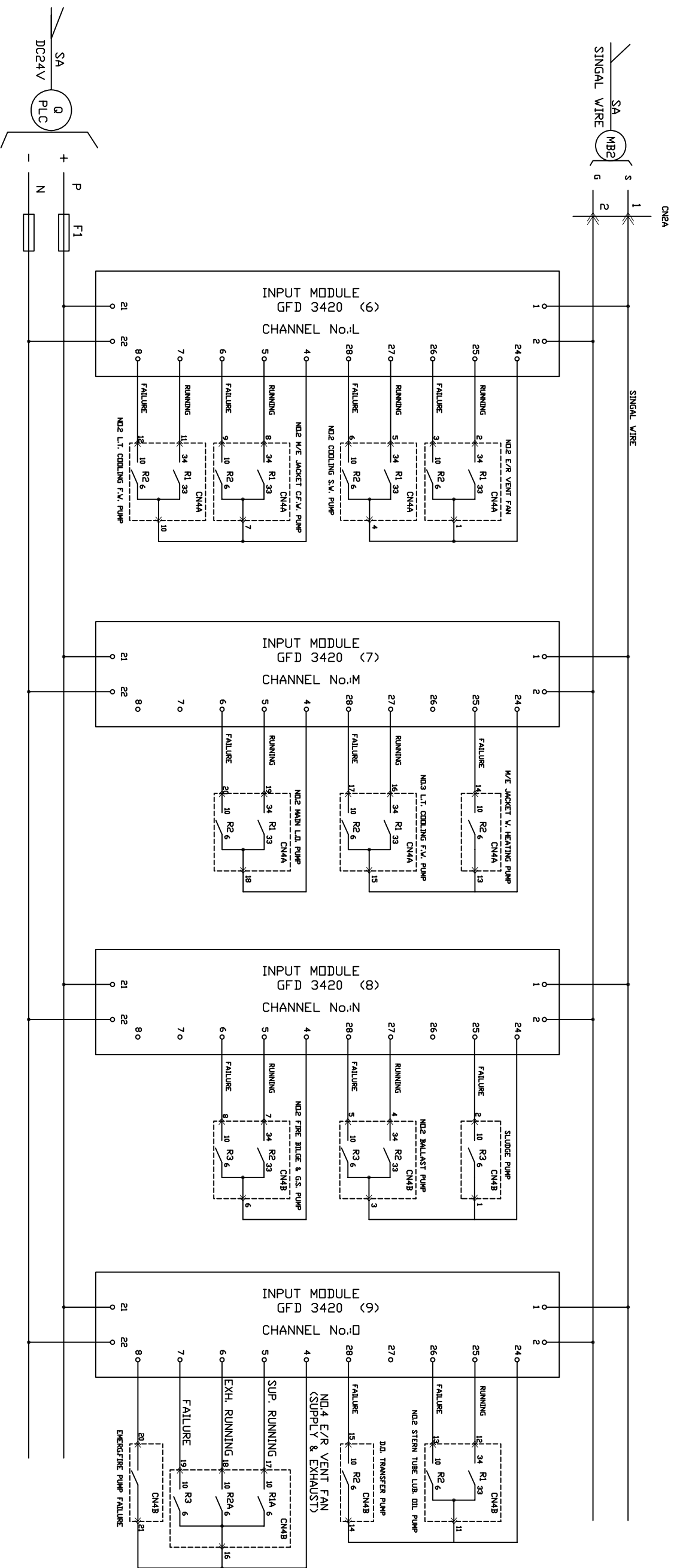

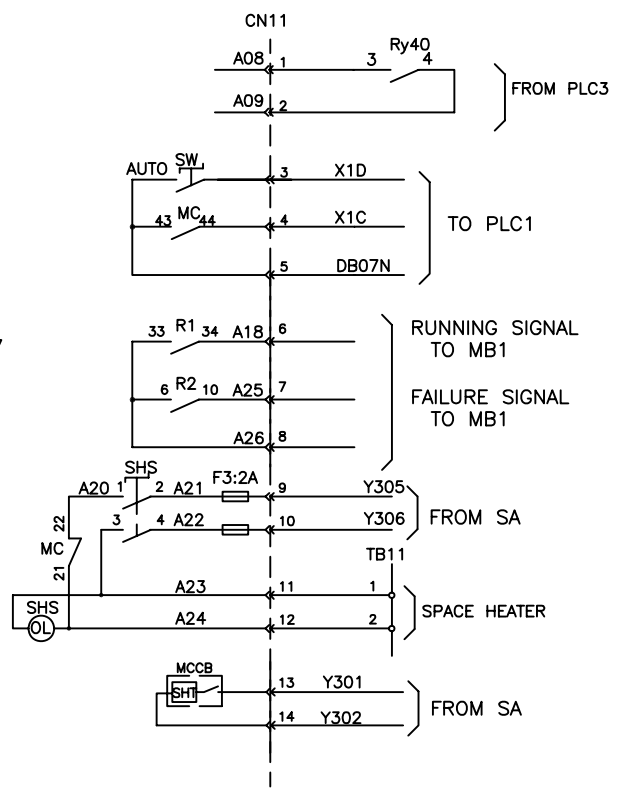
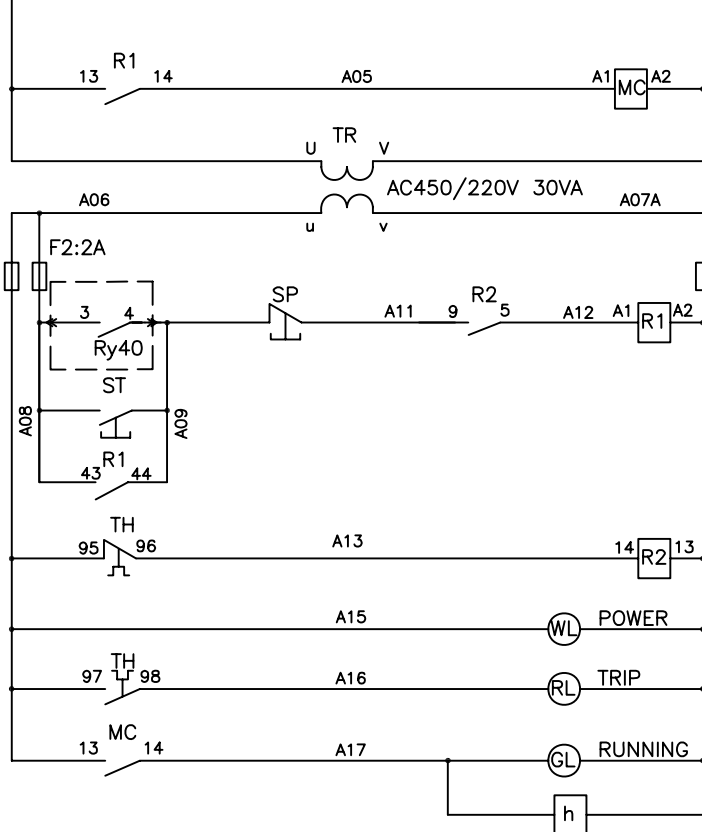
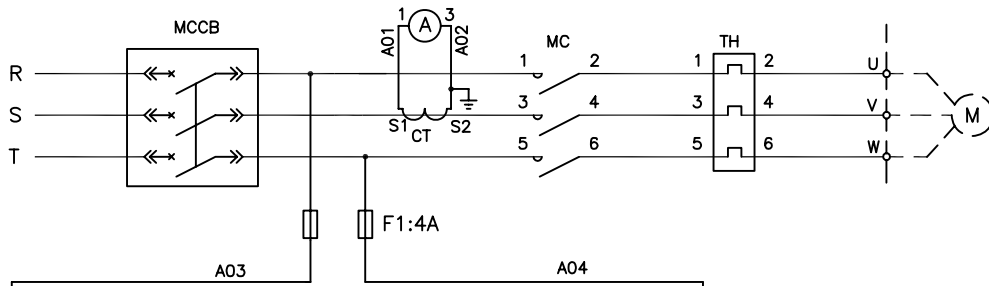

1GSP1

NO.1 E/R VENT.FAN

A B C D E F G H I



SCHEMATIC DIAGRAM

D1GSP1
2-11

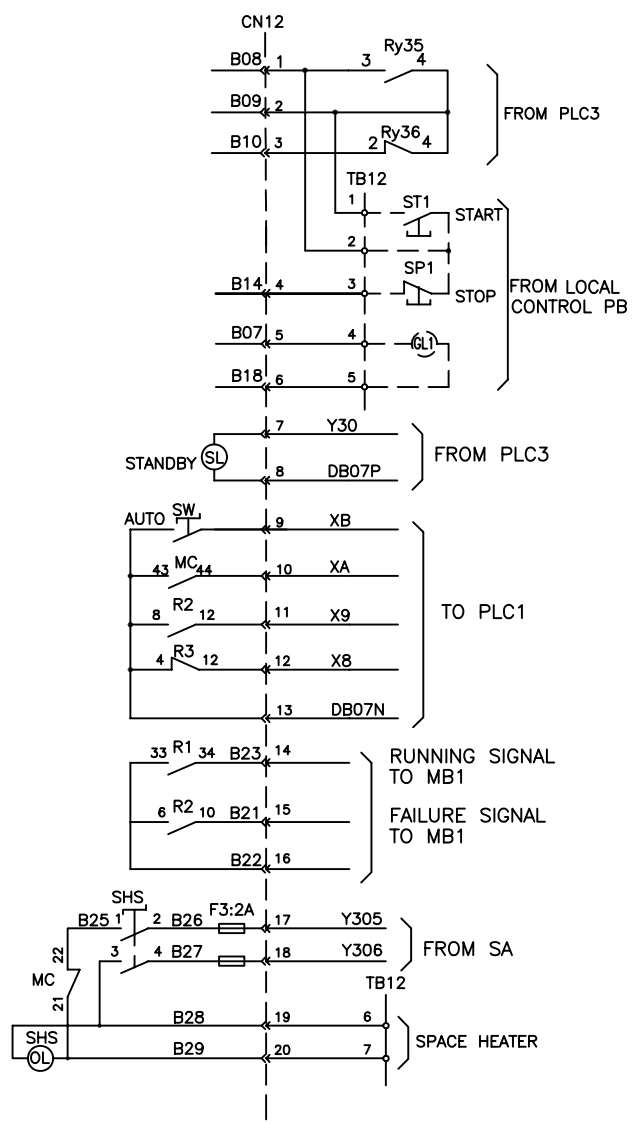
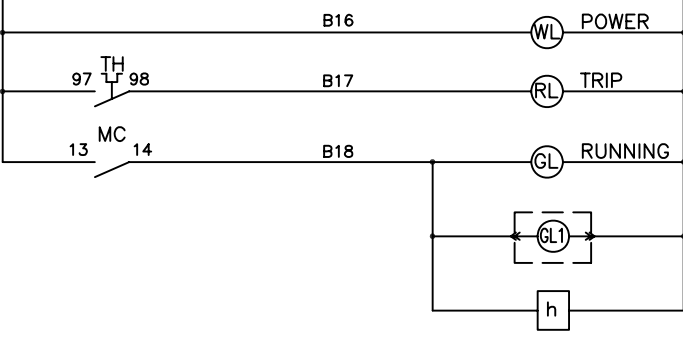
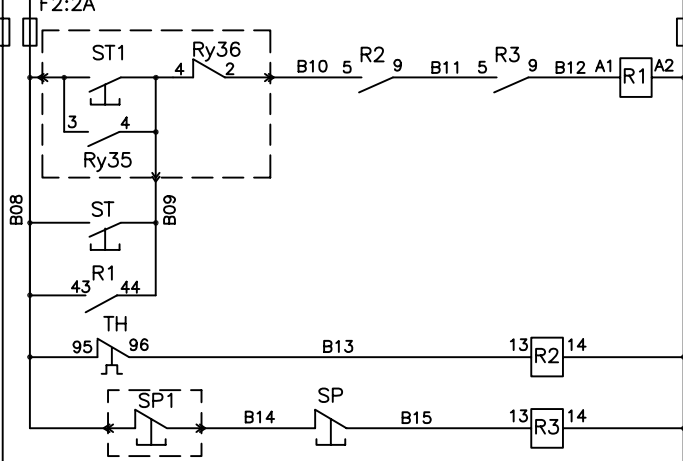
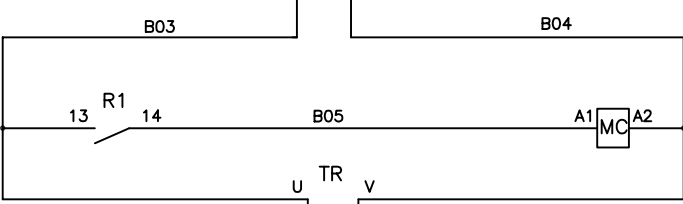
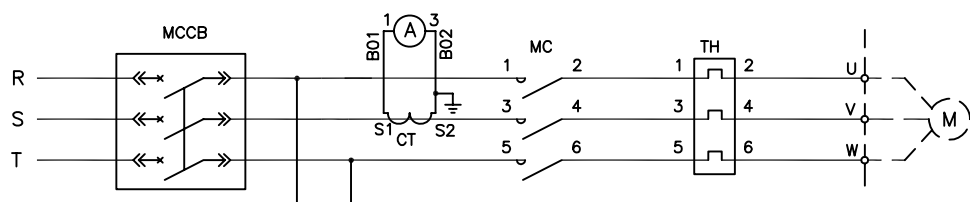

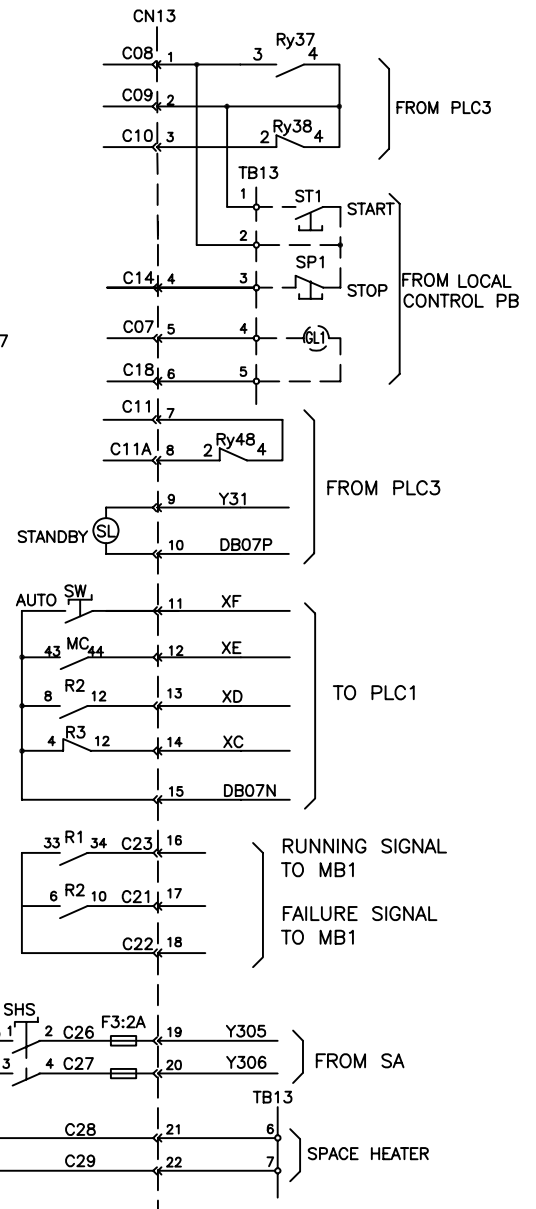
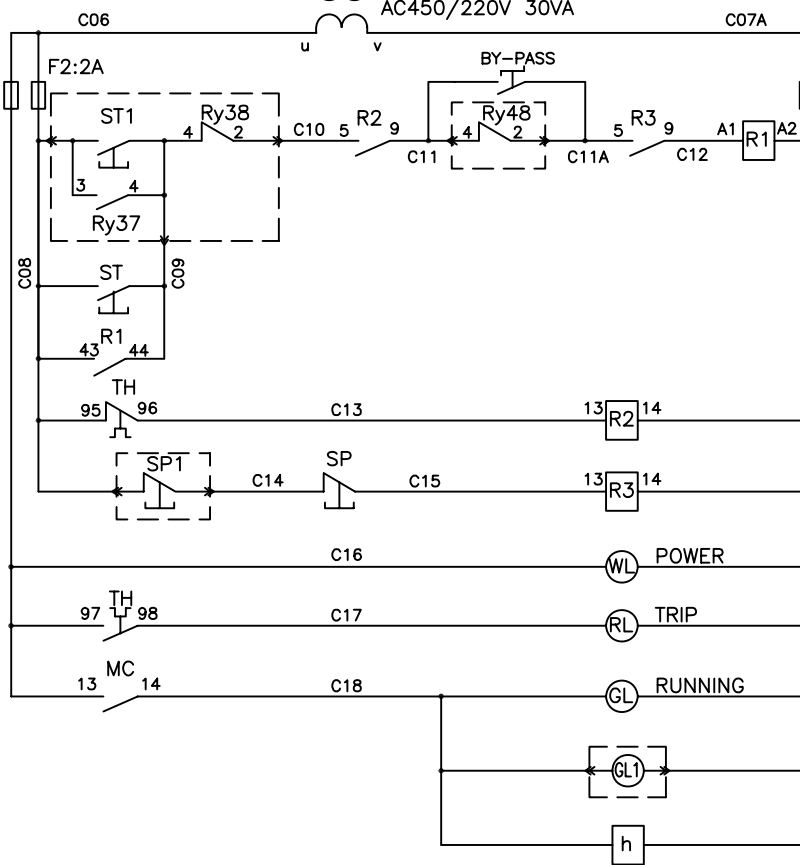
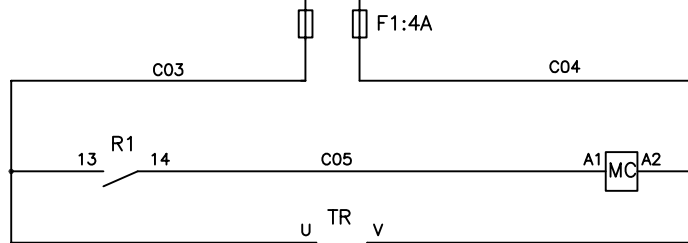
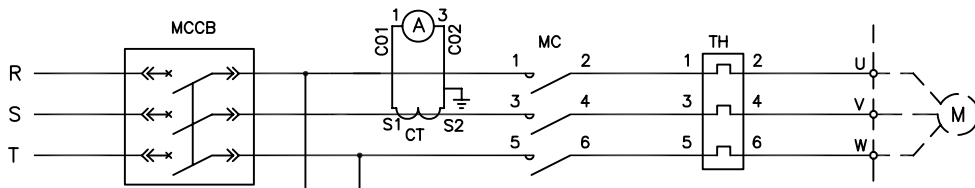

1GSP3 NO.1 M/E JACKET C.F.W. PUMP

SCHMATIC DIAGRAM

D1GSP3

2-13

A B C D E F G H I



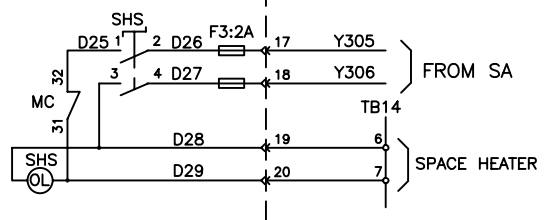
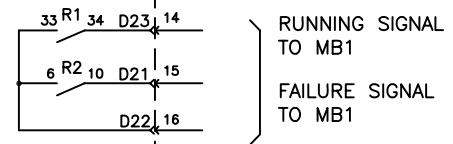
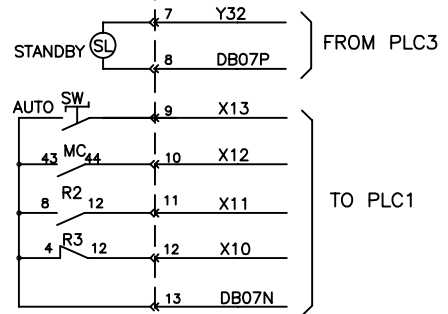
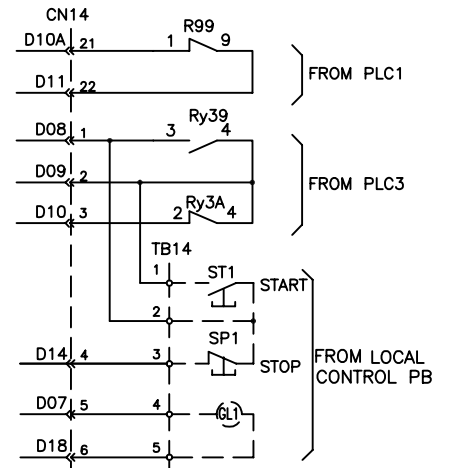
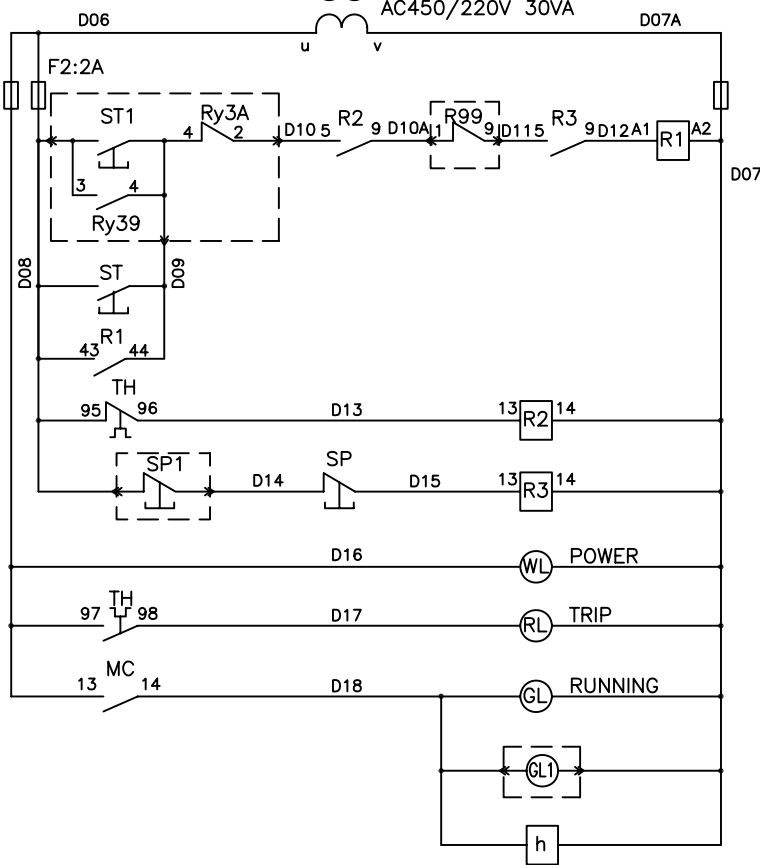
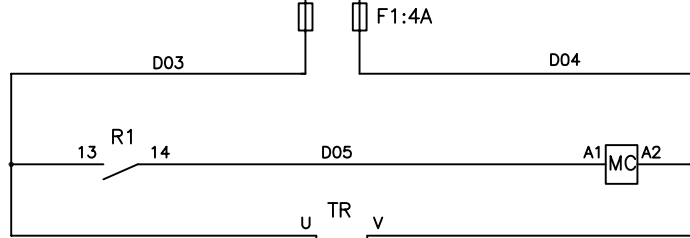
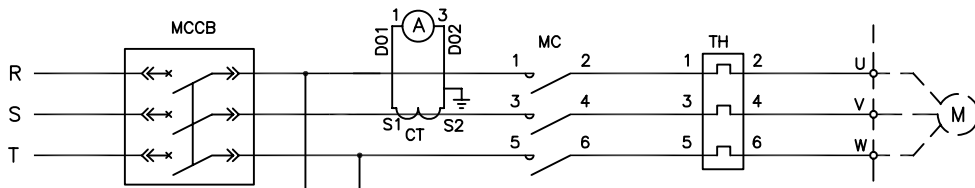

1GSP4 NO.1 COOLING S.W. PUMP

A B C D E F G H I



SCHEMATIC DIAGRAM

D1GSP4
2-14

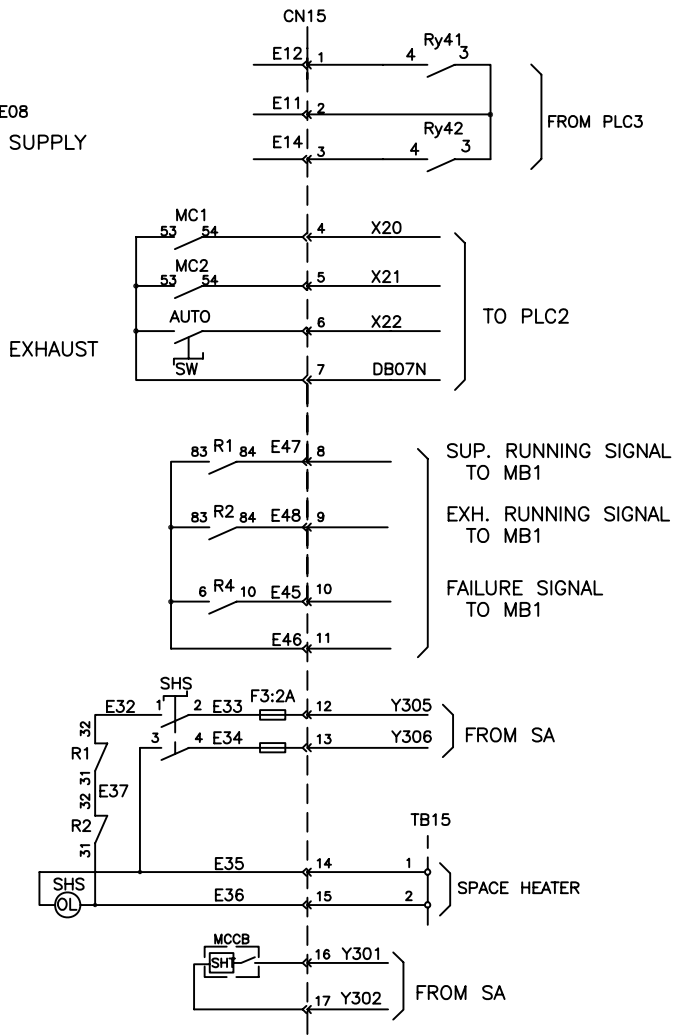
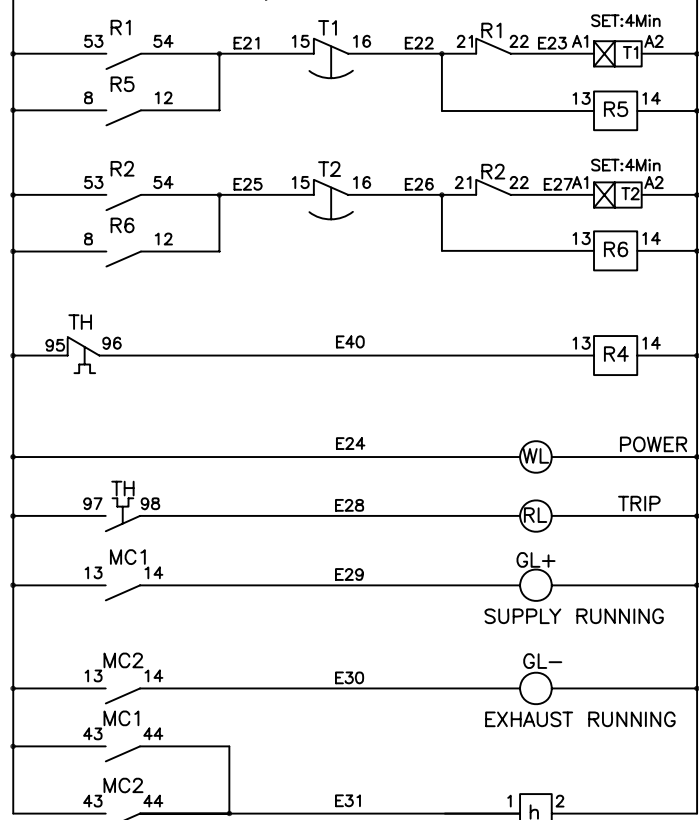
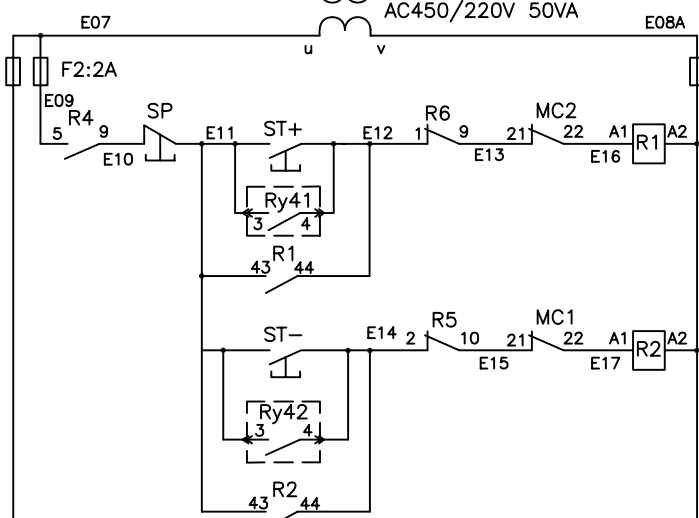
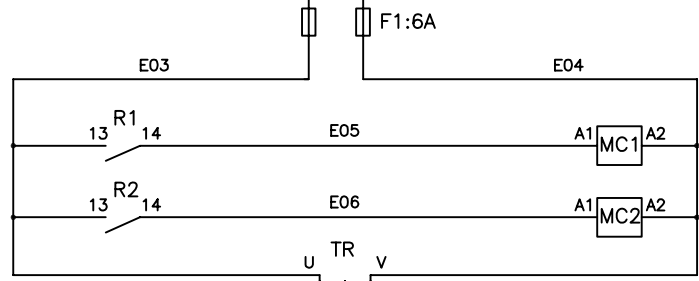
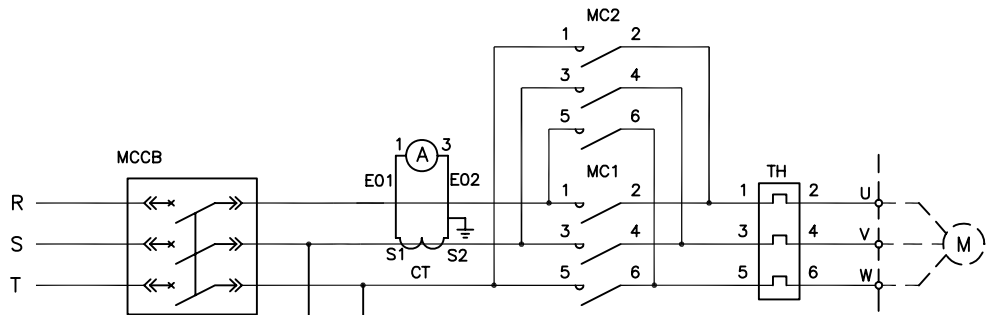

1GSP5 No.3 E/R VENT FAN (SUPPLY & EXHAUST)

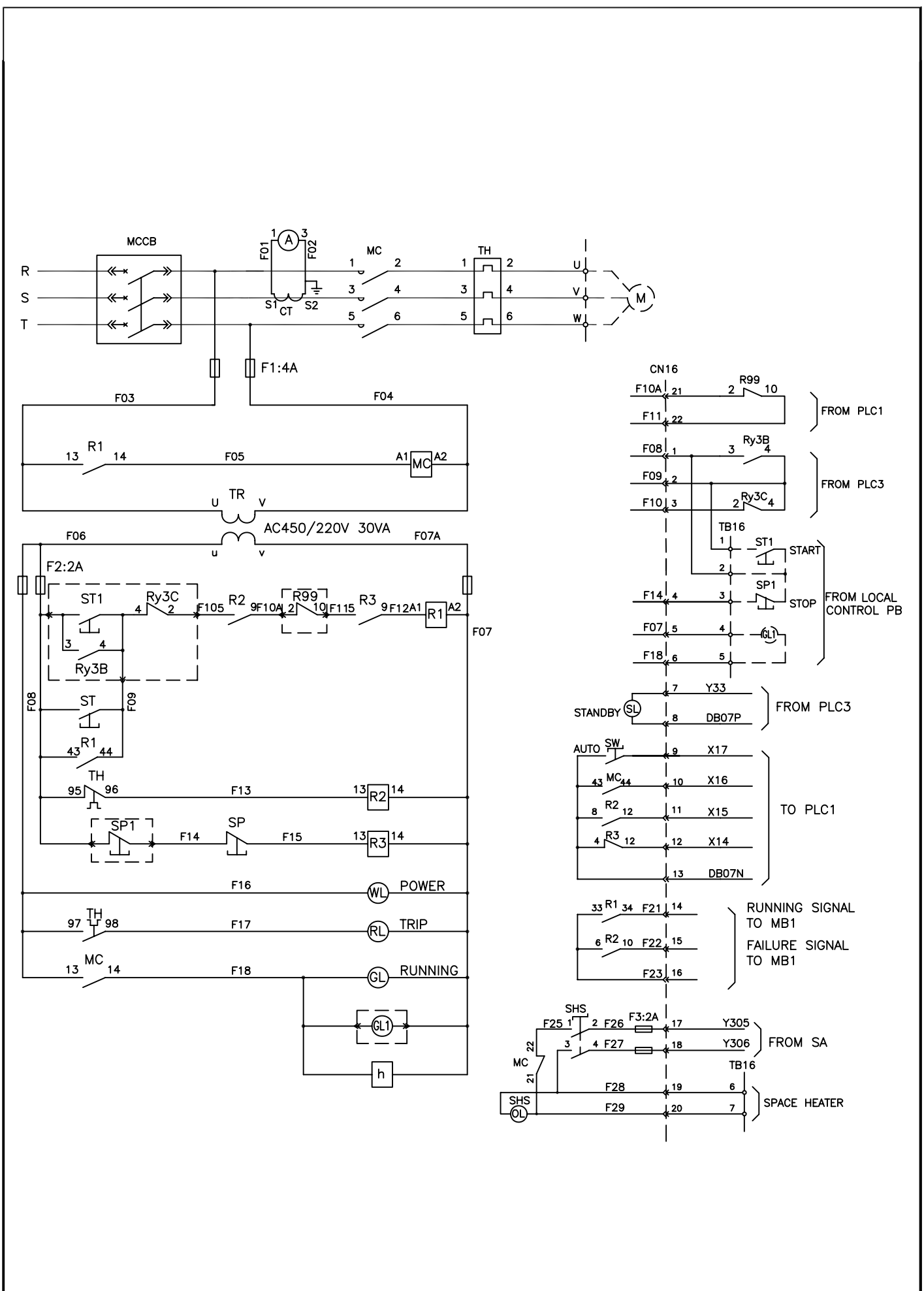

1GSP6 NO.3 COOLING S.W. PUMP

A B C D E F G H I



SCHMATIC DIAGRAM

D1GSP6
2-16

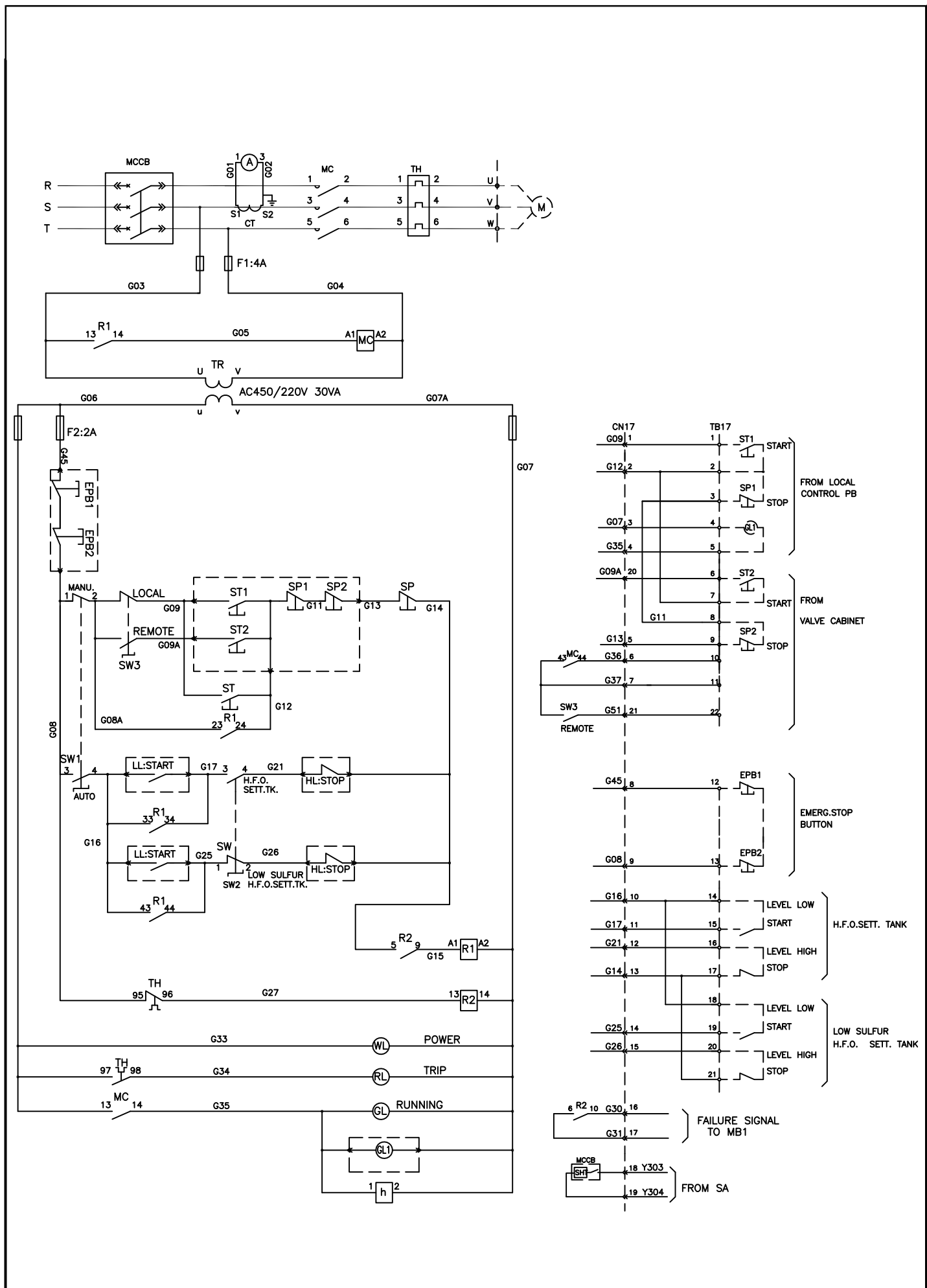

1GSP7 H.F.O.TRANSFER PUMP

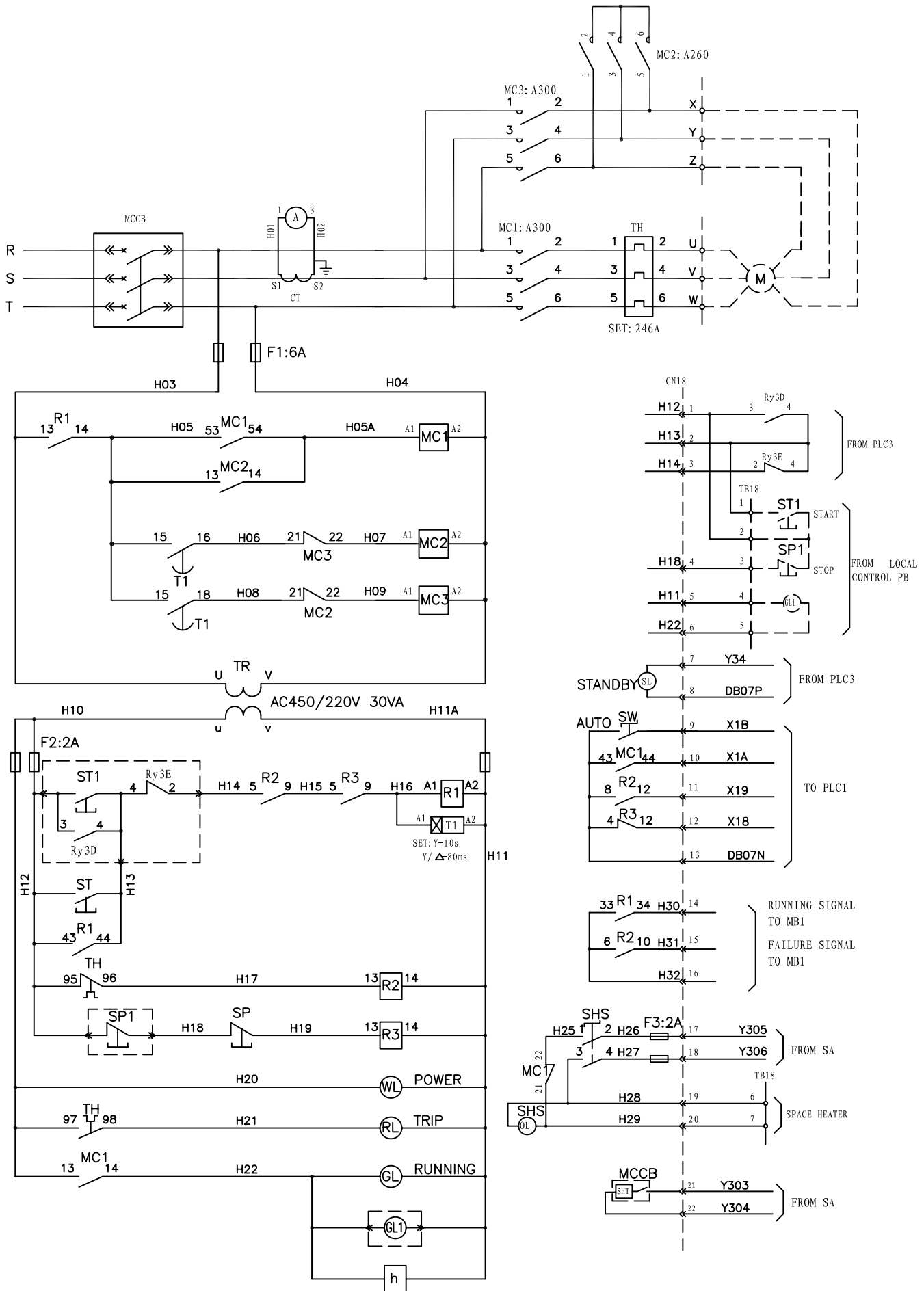

1GSP8	NO.1 MAIN L.O. PUMP
-------	---------------------

A	B	C	D	E	F	G	H	I
---	---	---	---	---	---	---	---	---



SCHEMATIC DIAGRAM

D1GSP8
2-18

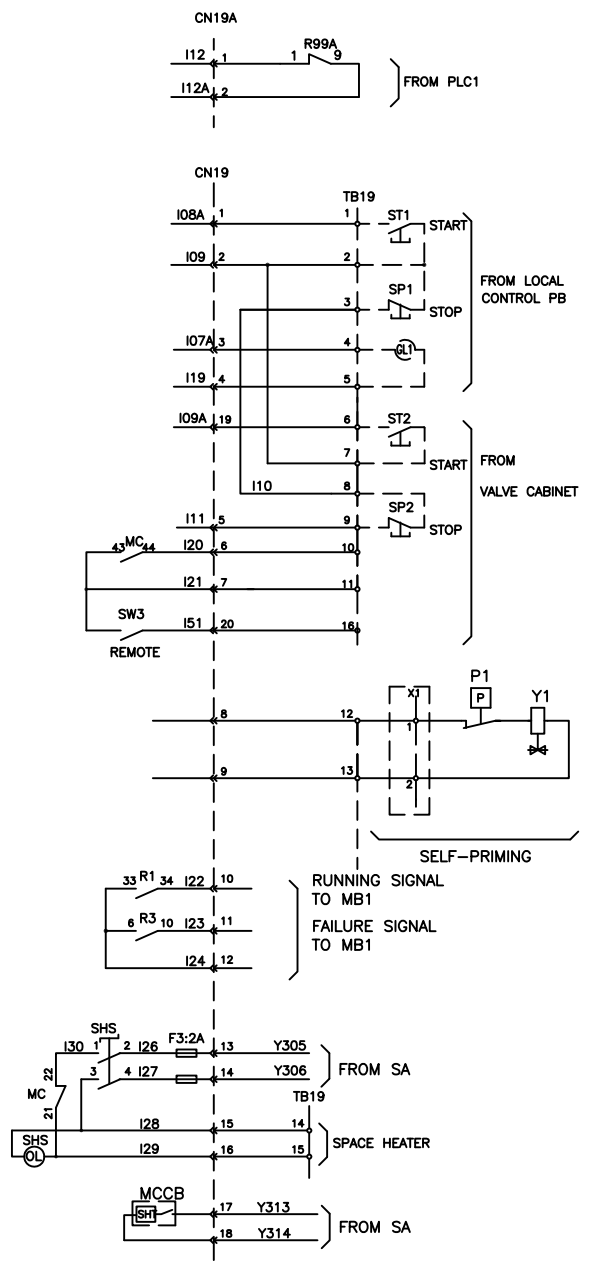
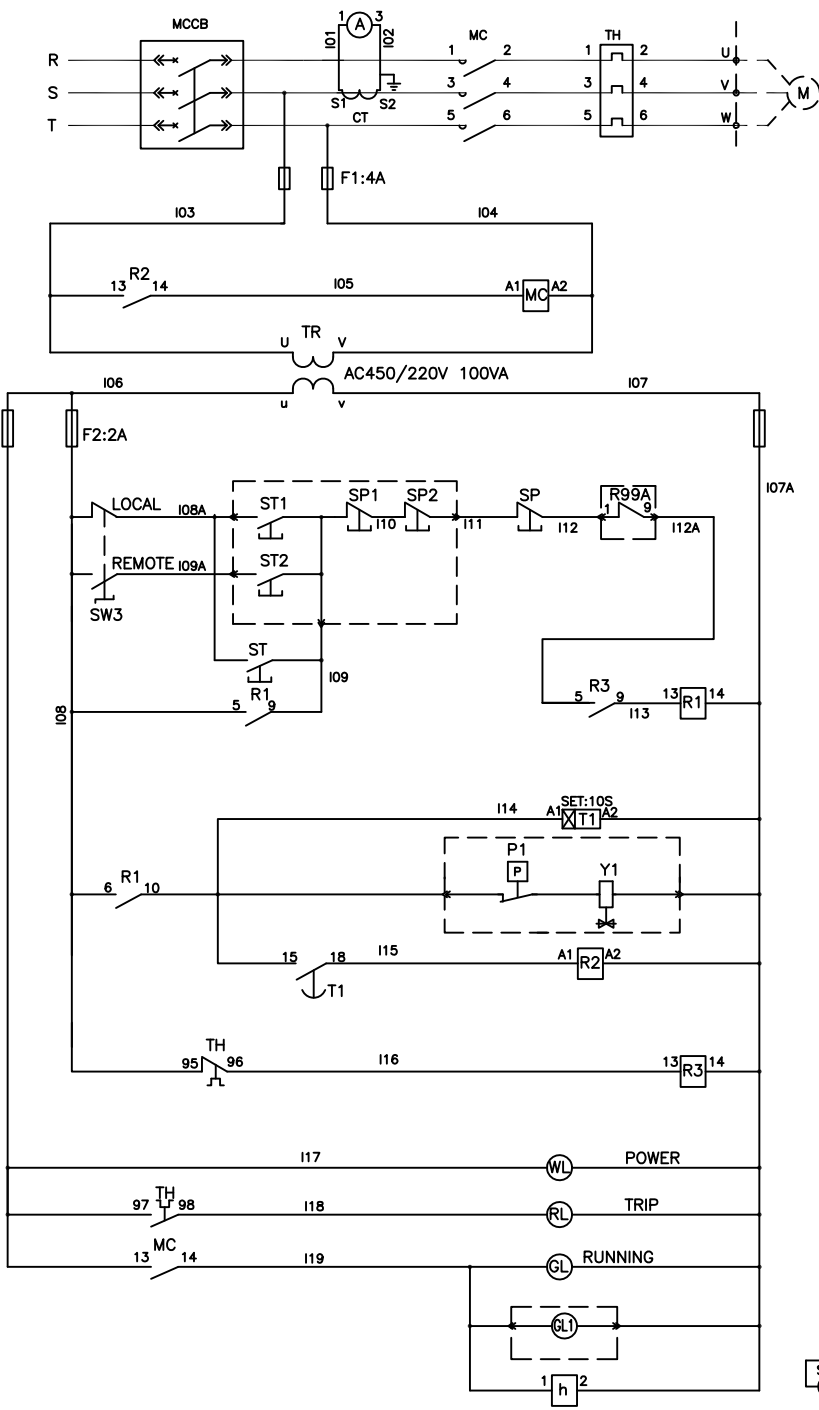

1GSP9 NO.1 BALLAST PUMP

A B C D E F G H I



SCHEMATIC DIAGRAM

D1GSP9
2-19

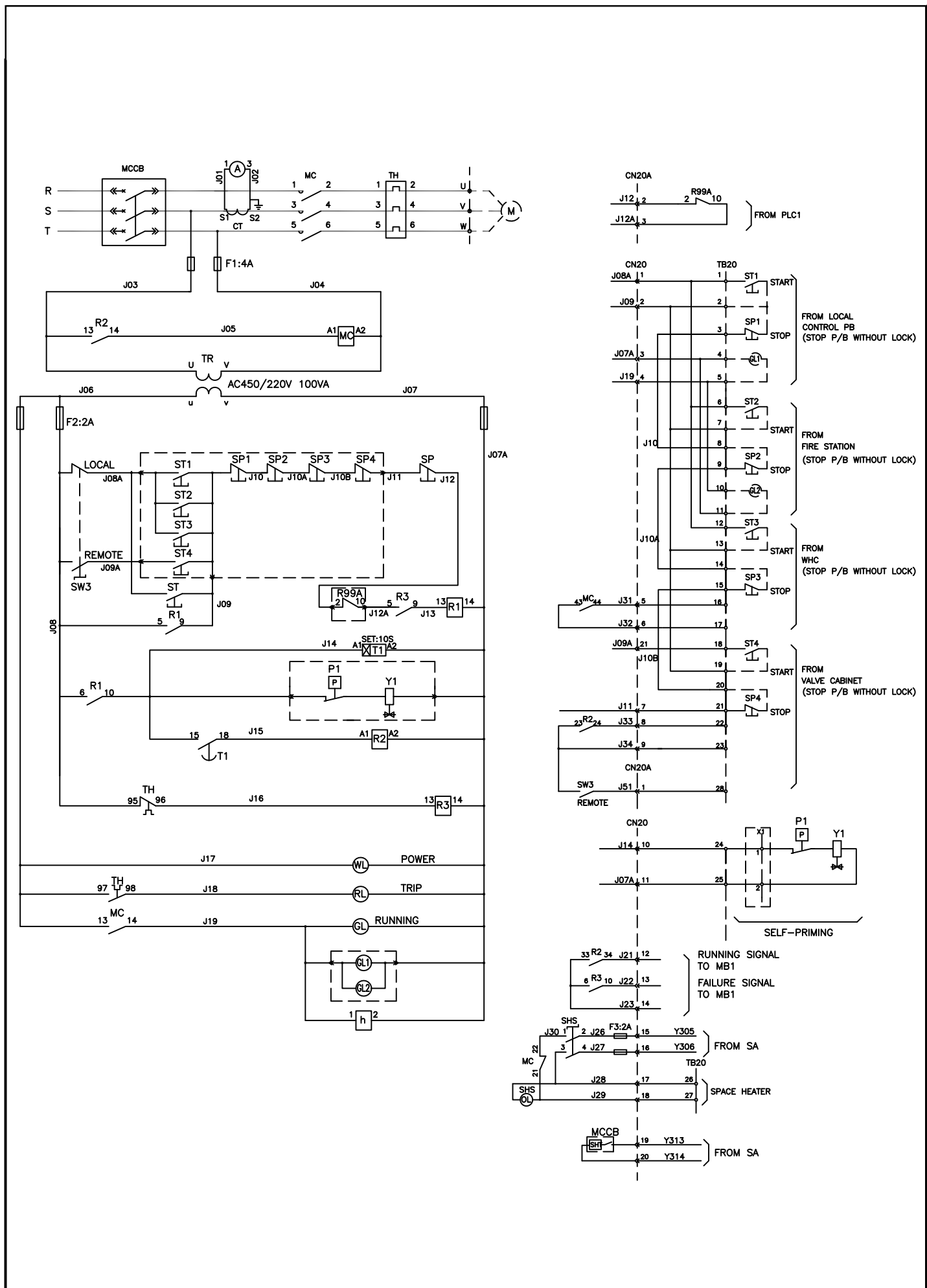

1GSP10 NO.1 FIRE BILGE & G.S. PUMP

A B C D E F G H I



SCHEMATIC DIAGRAM

D1GSP10
2-20

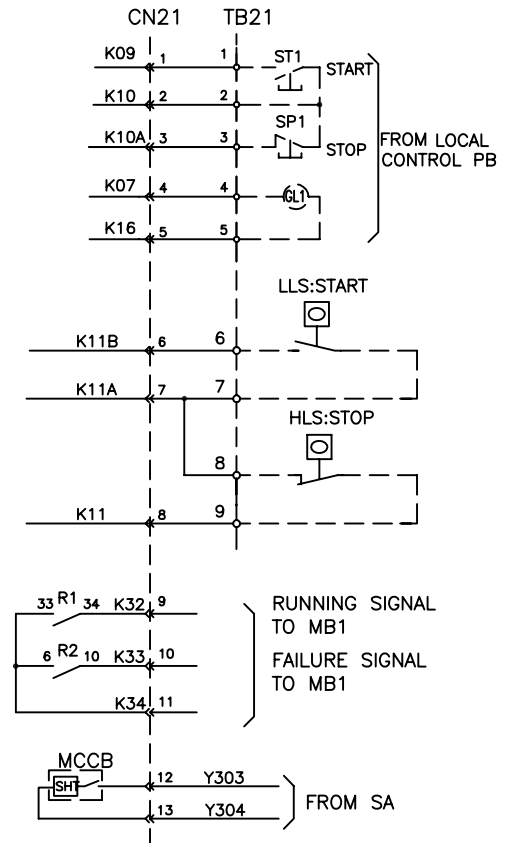
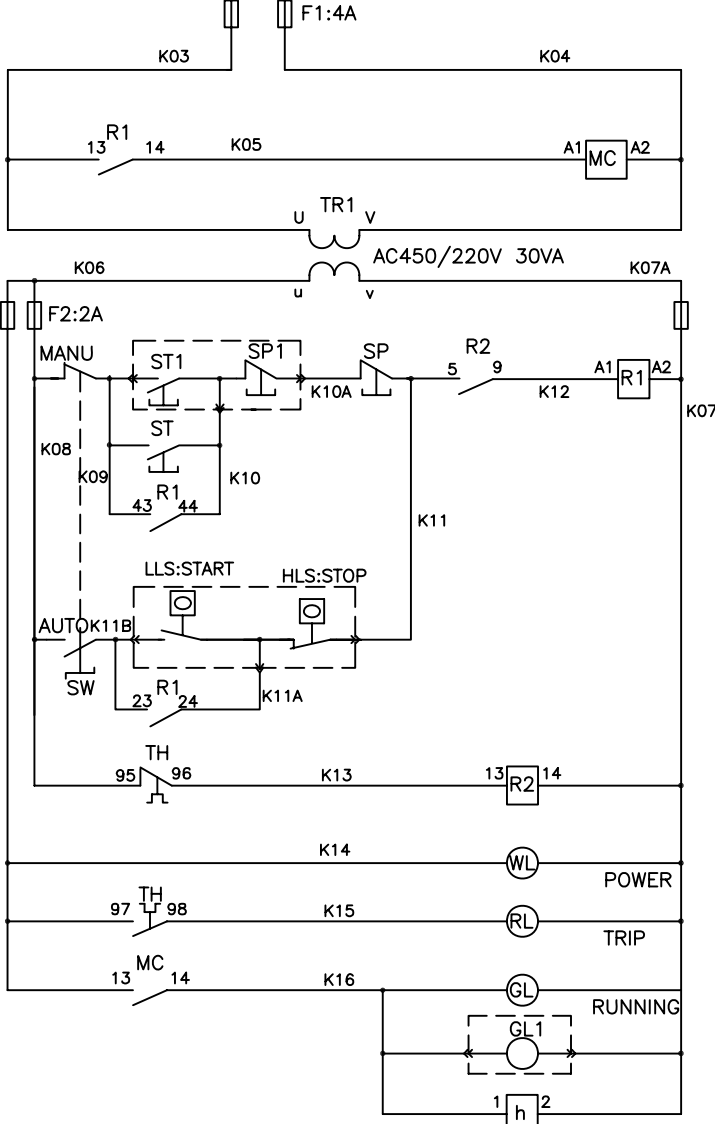
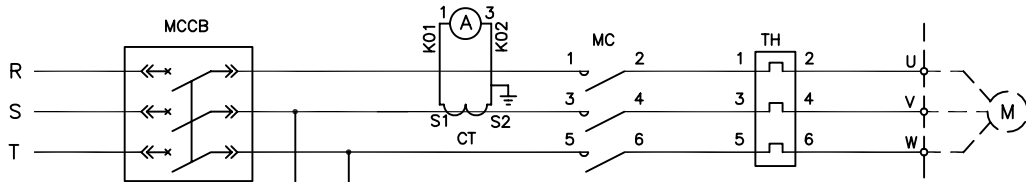

1GSP11 CYL. L.O. TRANSFER PUMP

A B C D E F G H I



SCHEMATIC DIAGRAM

D1GSP11
2-21

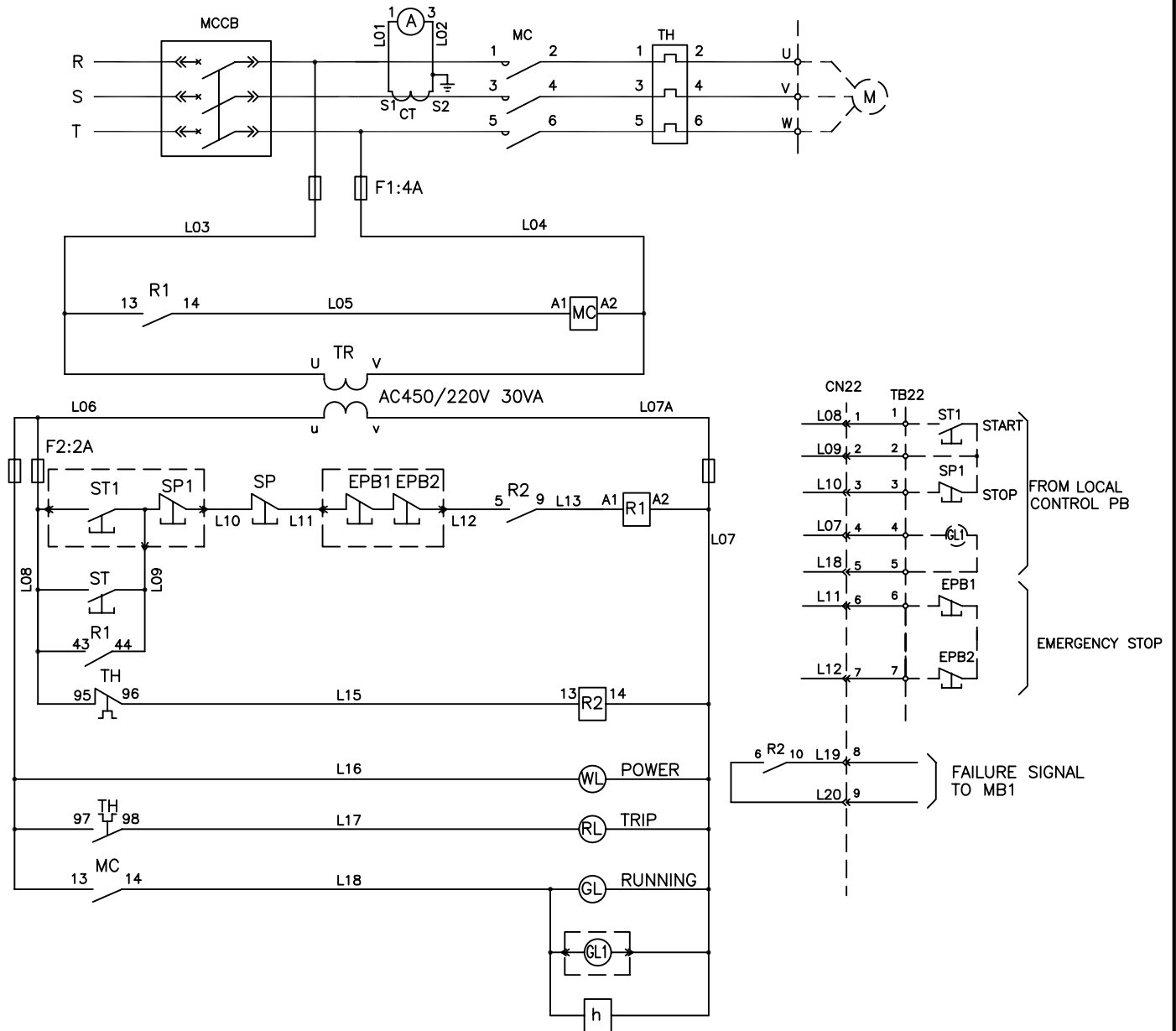

1GSP12 DAILY BILGE PUMP

A B C D E F G H I



SCHEMATIC DIAGRAM

D1GSP12
2-22

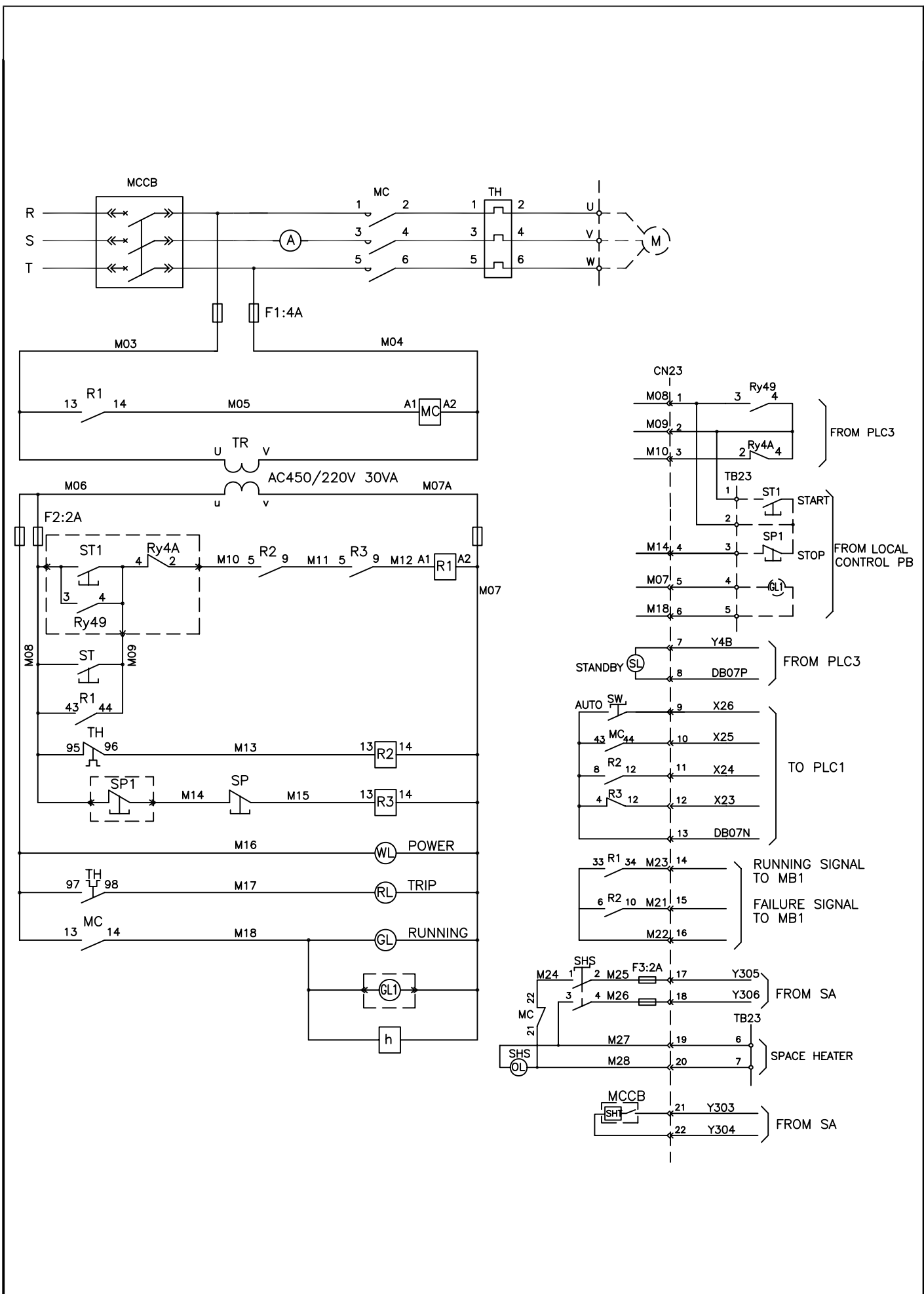

1GSP13 NO.1 STERN TUBE LUB. OIL PUMP

A B C D E F G H I



SCHEMATIC DIAGRAM

D1GSP13
2-23

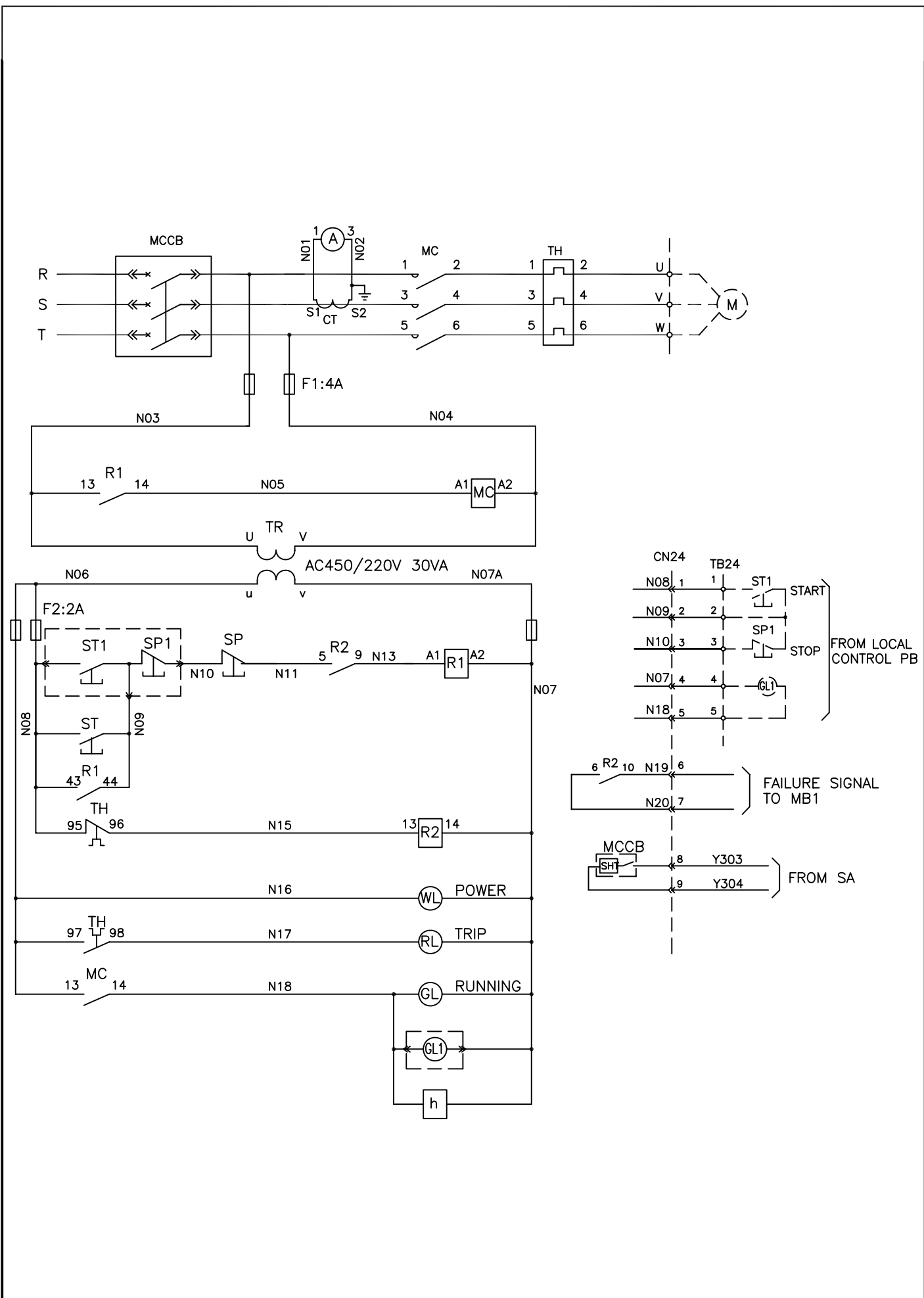

1GSP14	L.O. TRANSFER PUMP
--------	--------------------

A	B	C	D	E	F	G	H	I
---	---	---	---	---	---	---	---	---



SCHMATIC DIAGRAM

D1GSP14
2-24

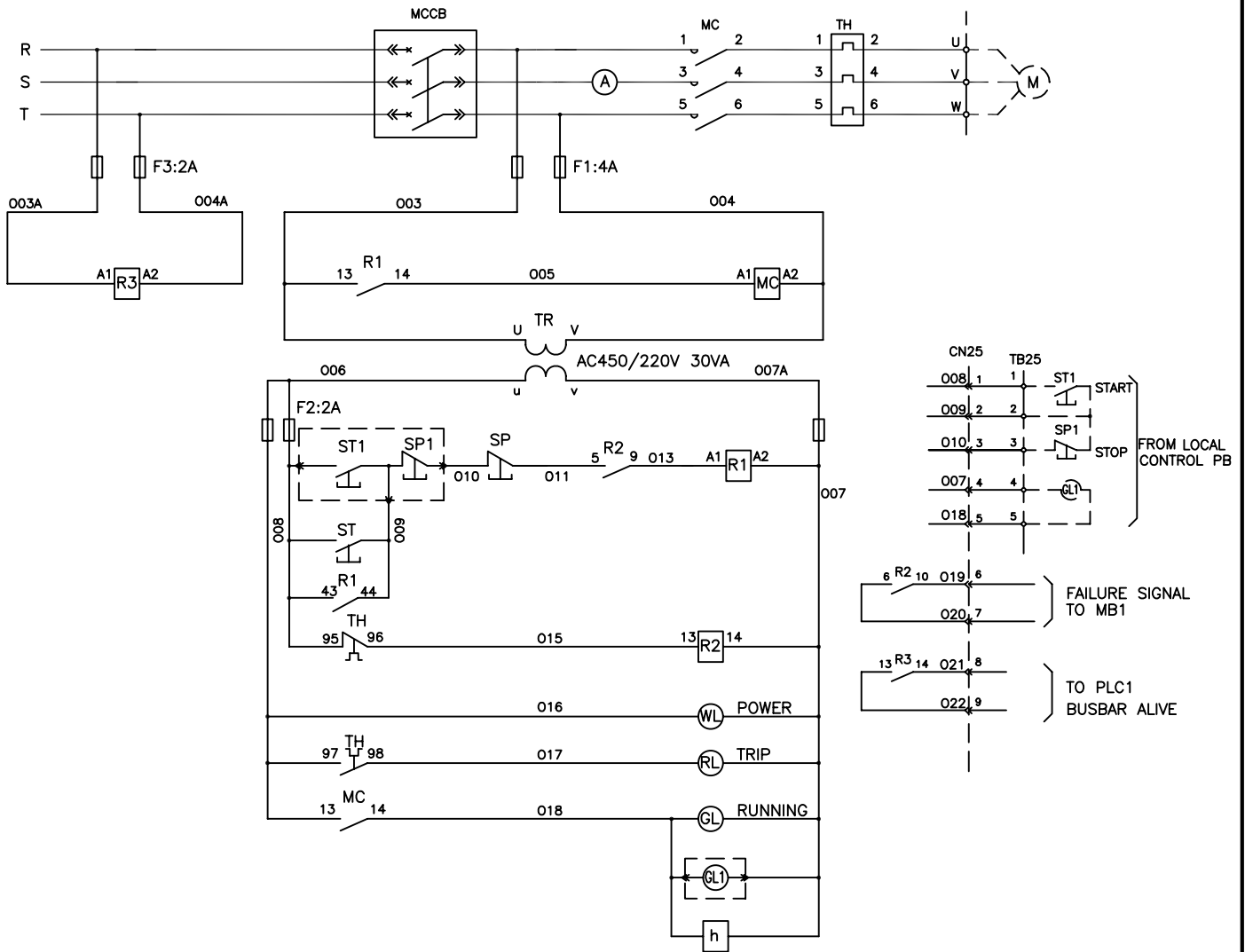

1GSP15 AIR COOLER CHEMICAL CLEANING PUMP

A B C D E F G H I



SCHEMATIC DIAGRAM

D1GSP15
2-25

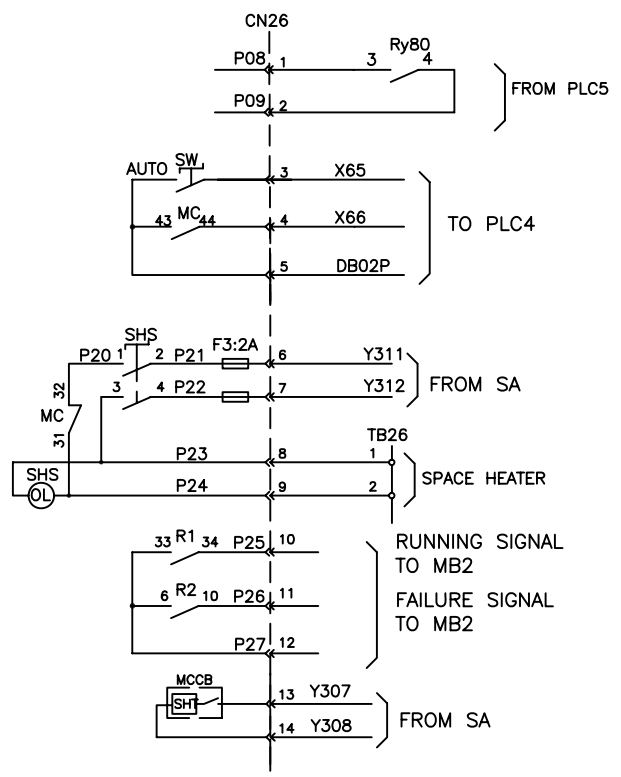
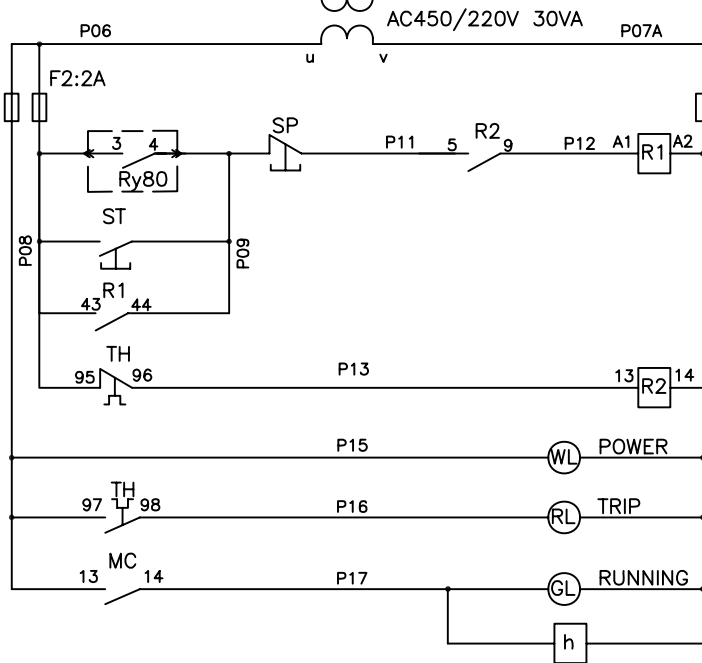
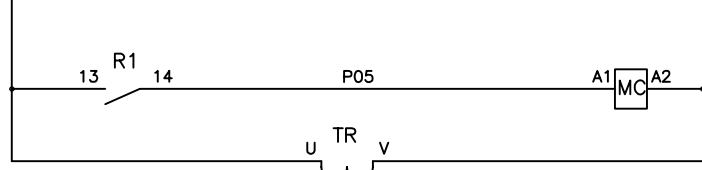
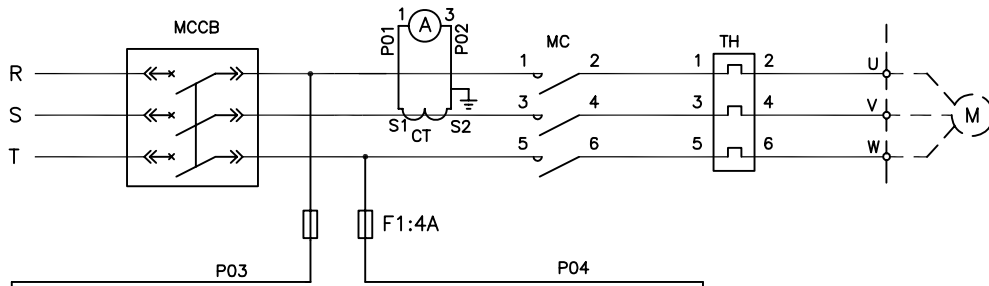

2GSP1

NO.2 E/R VENT.FAN

SCHMATIC DIAGRAM

D2GSP1
2-26

A B C D E F G H I



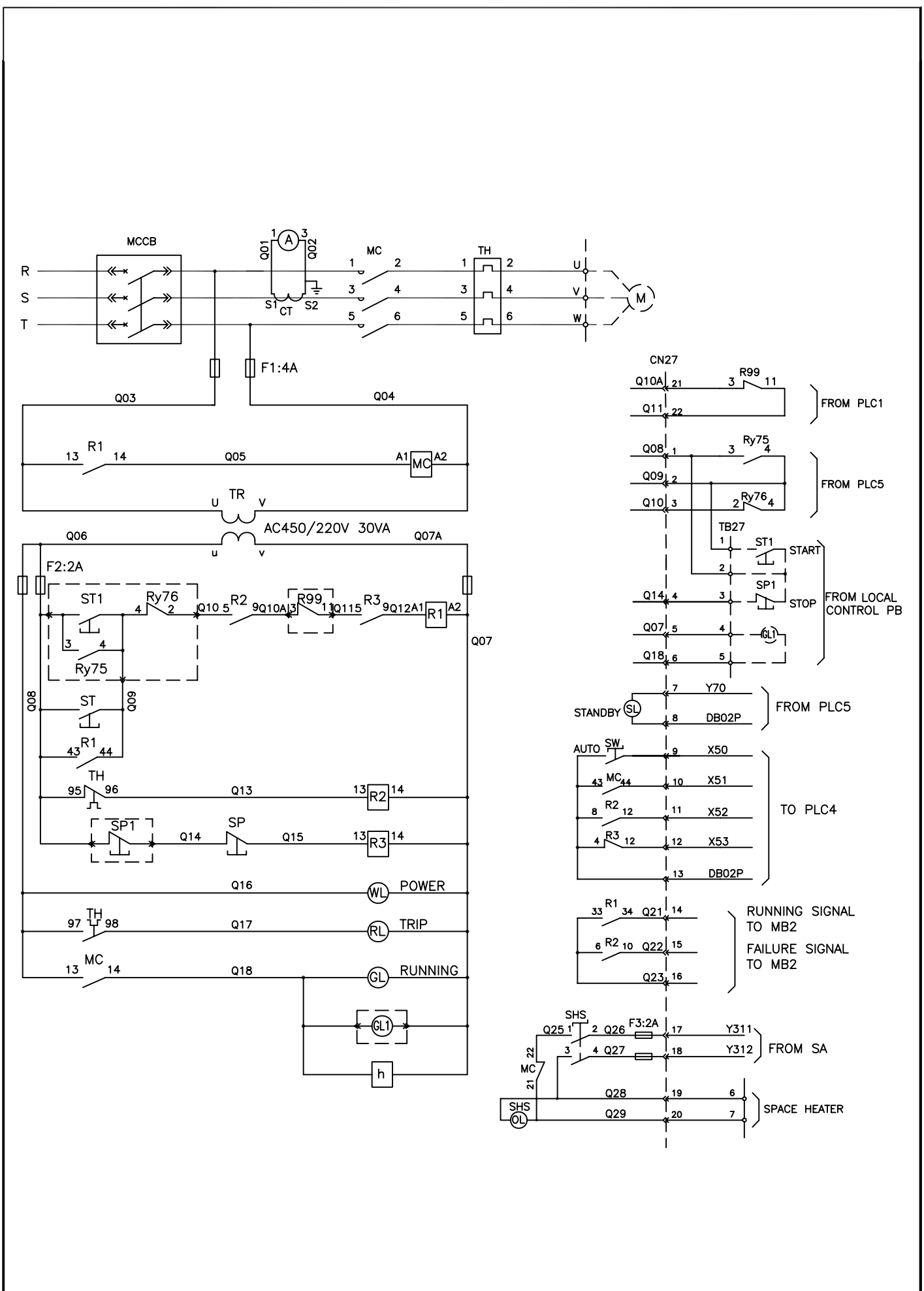

2GSP2 NO.2 COOLING S.W. PUMP

A B C D E F G H I



SCHMATIC DIAGRAM

D2GSP2
2-27

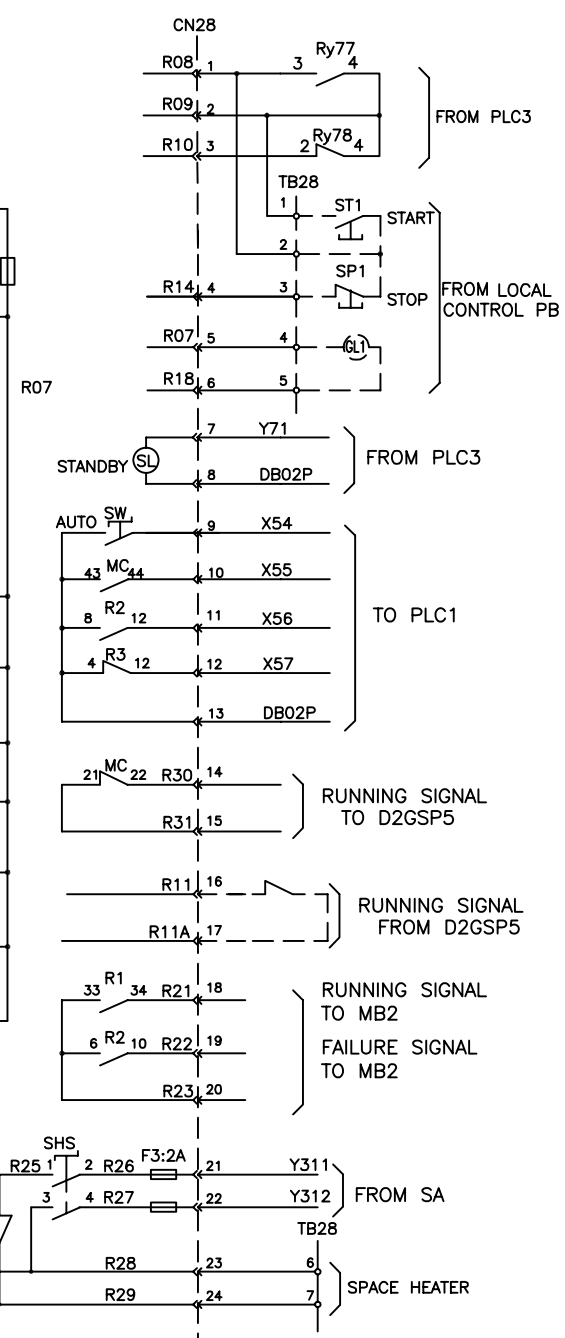
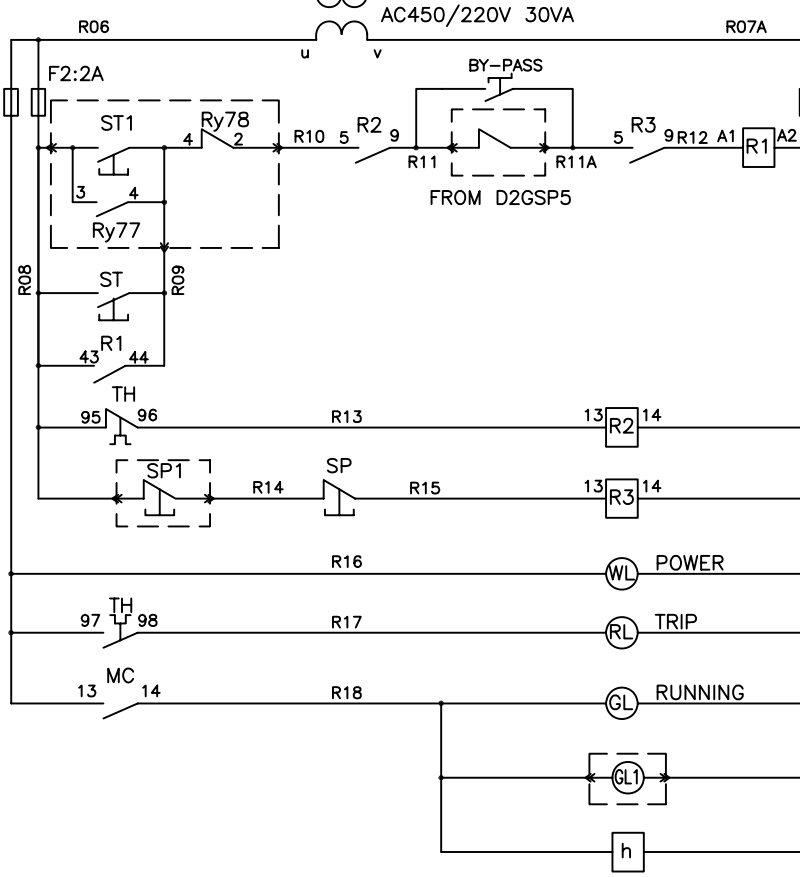
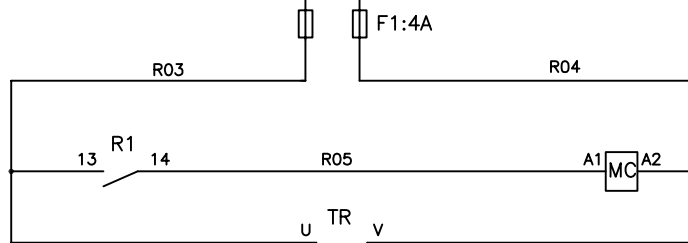
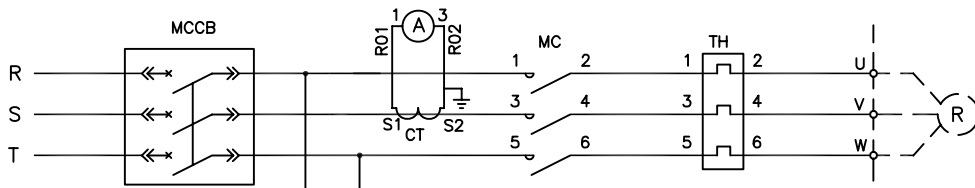

2GSP3 NO.2 M/E JACKET C.F.W. PUMP

A B C D E F G H I



SCHMATIC DIAGRAM

D2GSP3
2-28

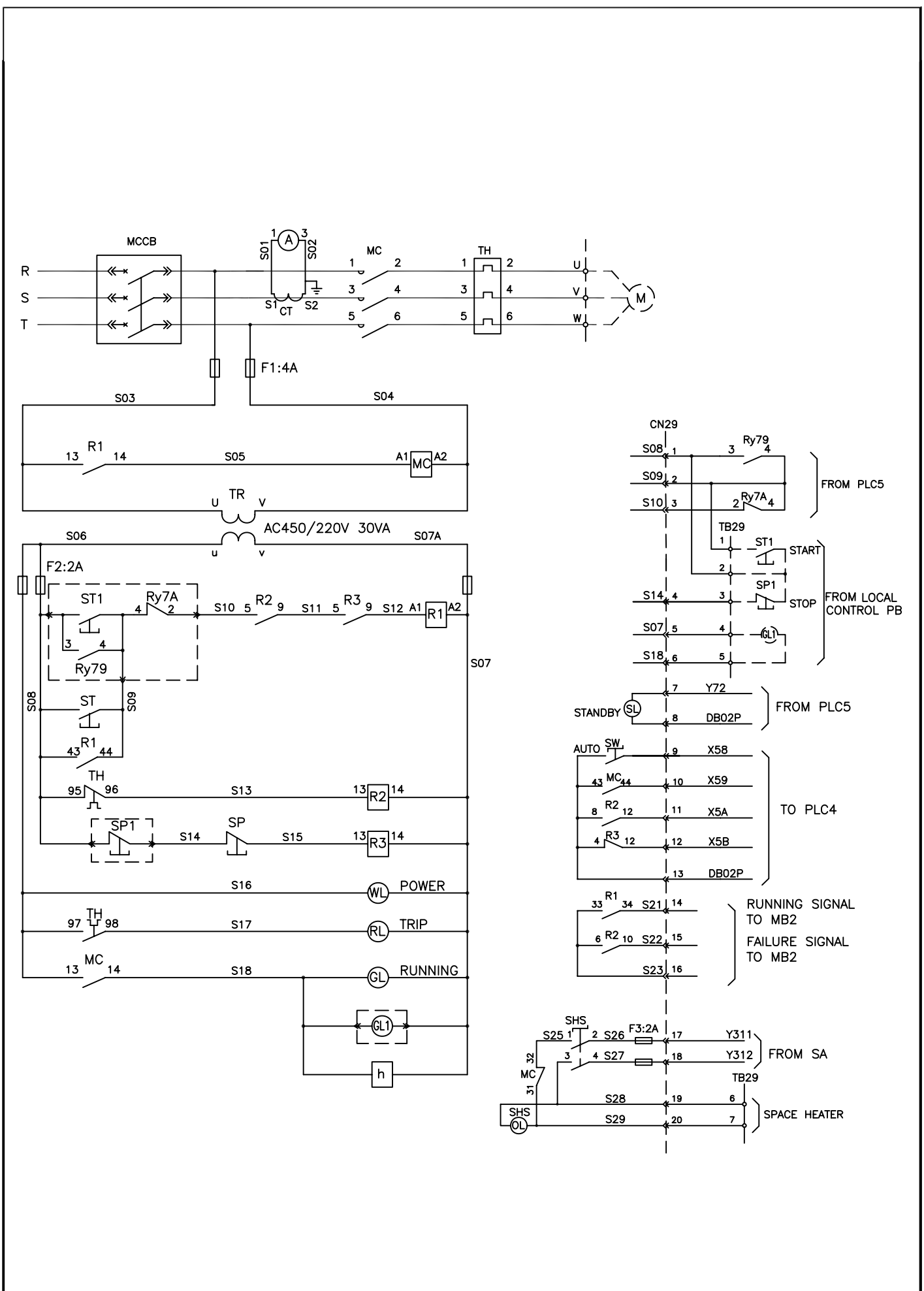

2GSP4 NO.2 L.T. COOLING F.W. PUMP

A B C D E F G H I



SCHEMATIC DIAGRAM

D2GSP4
2-29

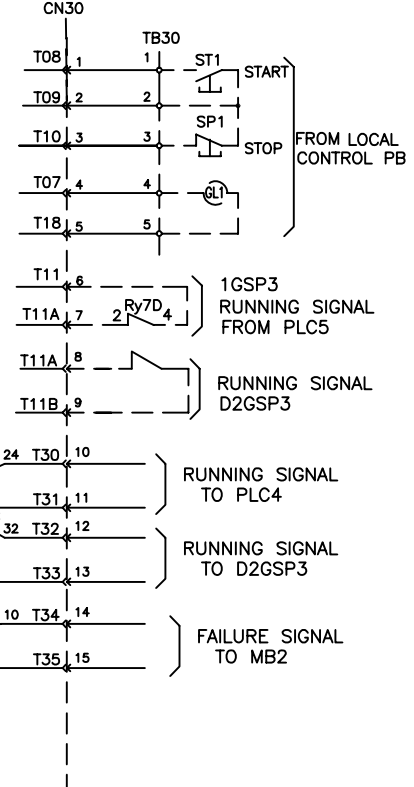
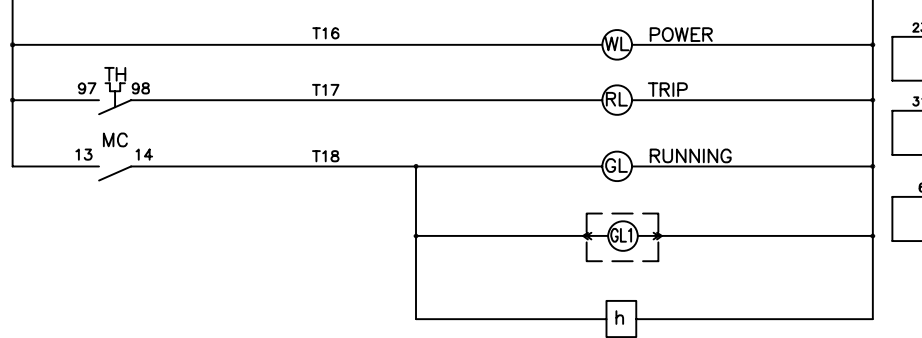
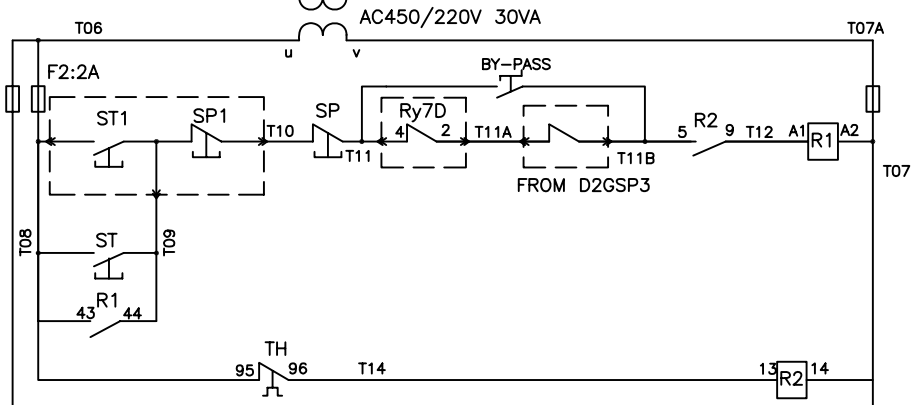
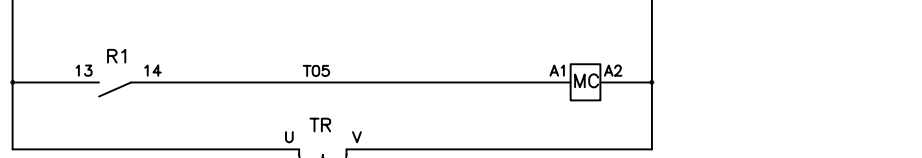
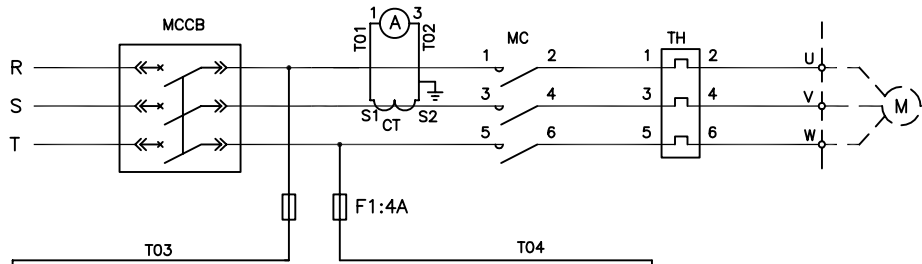

2GSP5 M/E JACKET W.HEATING PUMP

A B C D E F G H I



SCHEMATIC DIAGRAM

D2GSP5
2-30

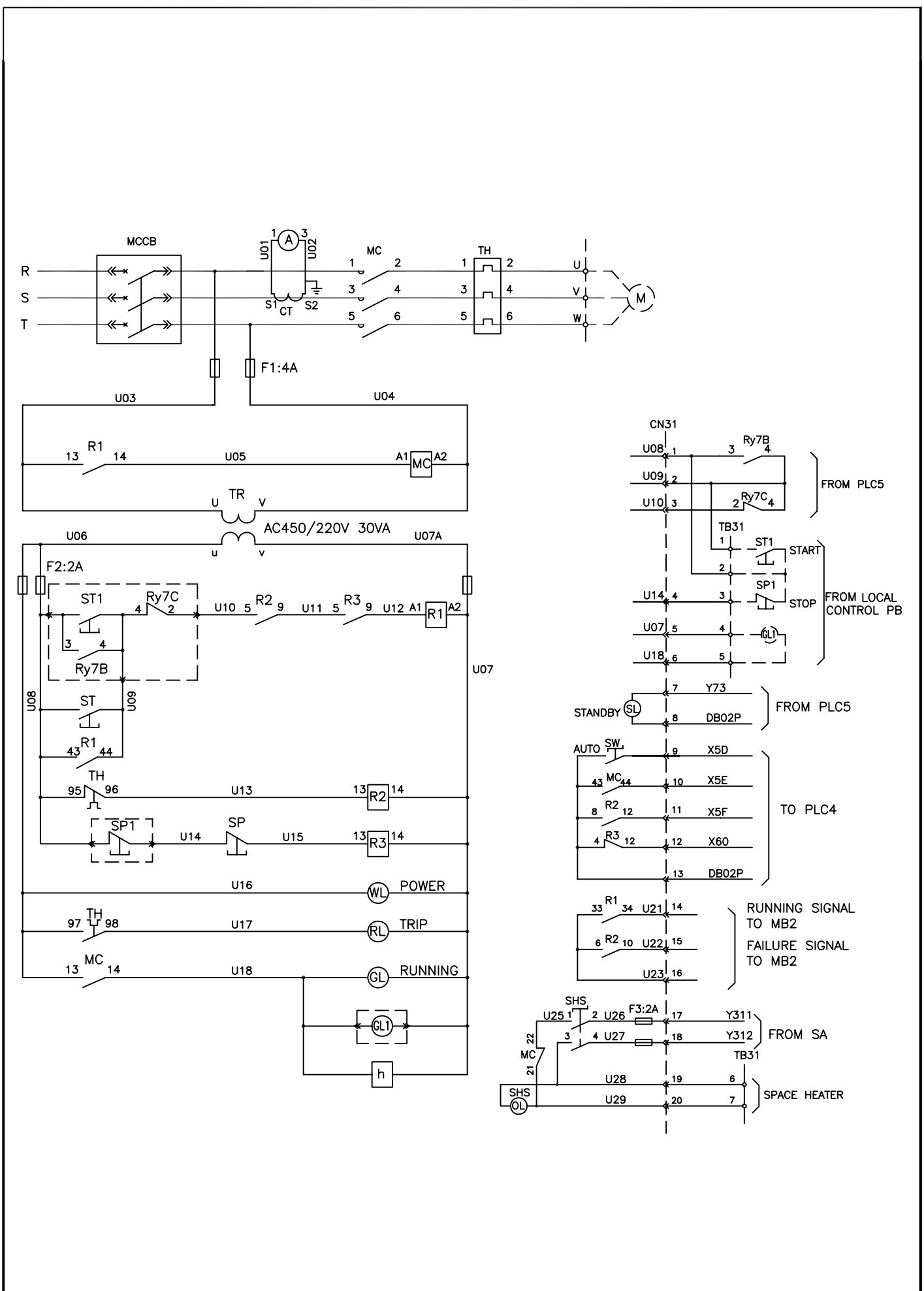

2GSP6 NO.3 L.T. COOLING F.W. PUMP

A B C D E F G H I



SCHMATIC DIAGRAM

D2GSP6
2-31

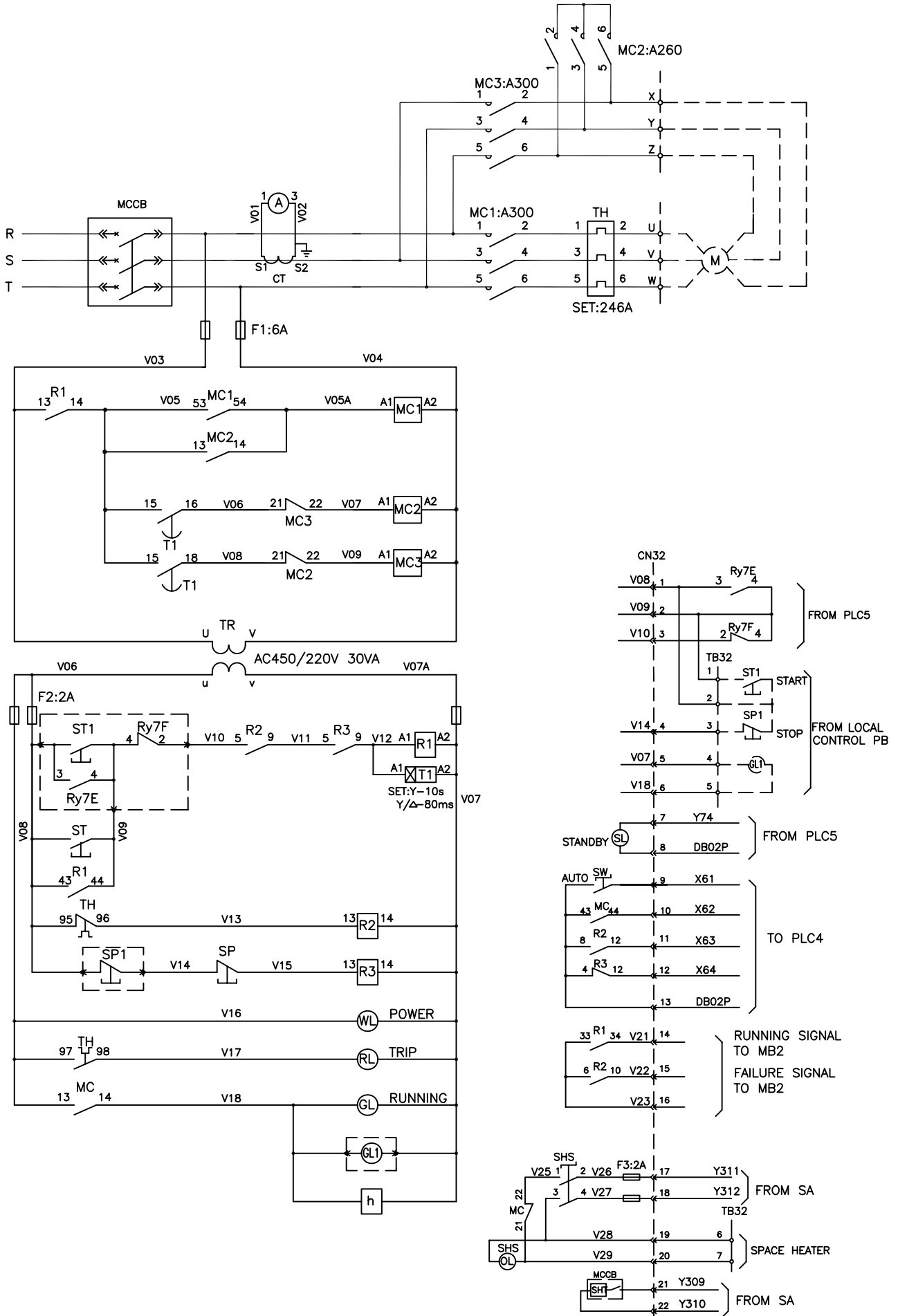

2GSP7 NO.2 MAIN L.O. PUMP

A B C D E F G H I



SCHEMATIC DIAGRAM

D2GSP7
2-32

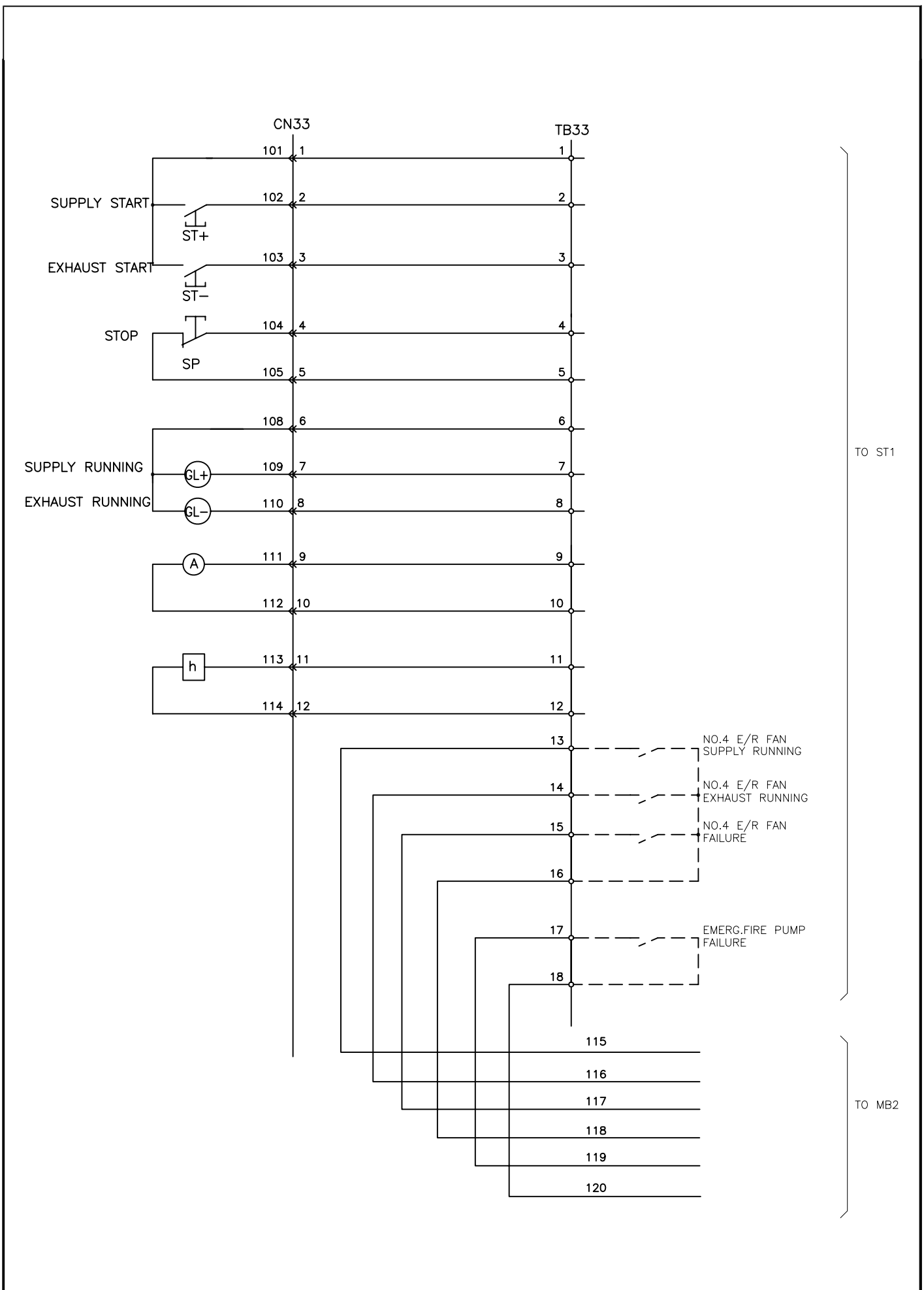

2GSP8 NO.4 E/R VENT. FAN (SUPPLY & EXHAUST)

A B C D E F G H I



SCHEMATIC DIAGRAM

D2GSP8
2-33

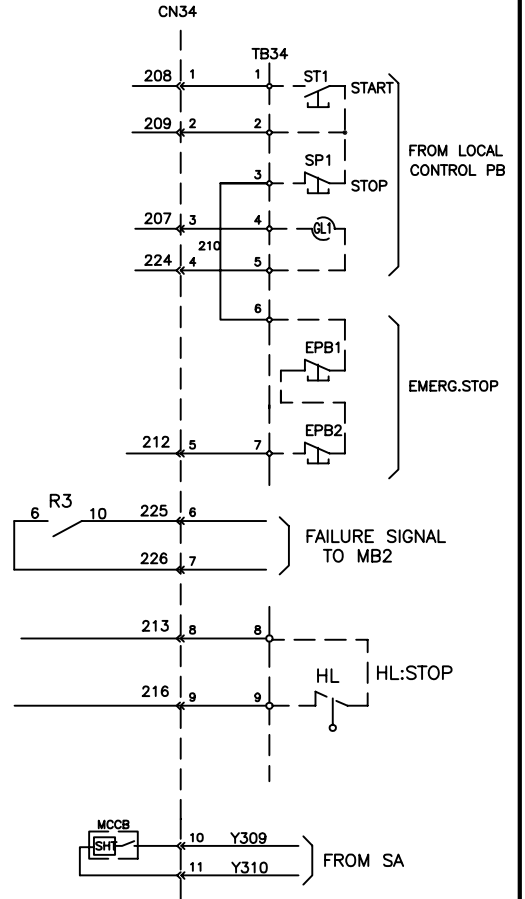
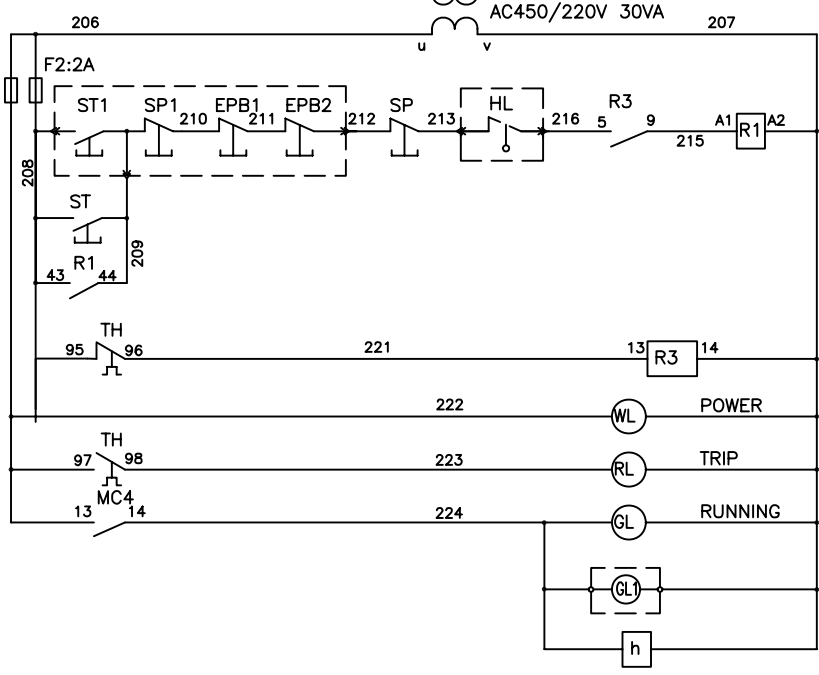
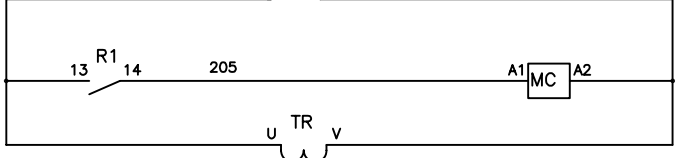
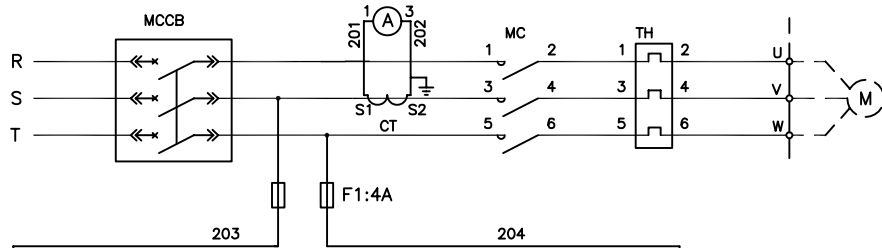

2GSP9 SLUDGE PUMP

A B C D A F G H I



SCHEMATIC DIAGRAM

D2GSP9
2-34

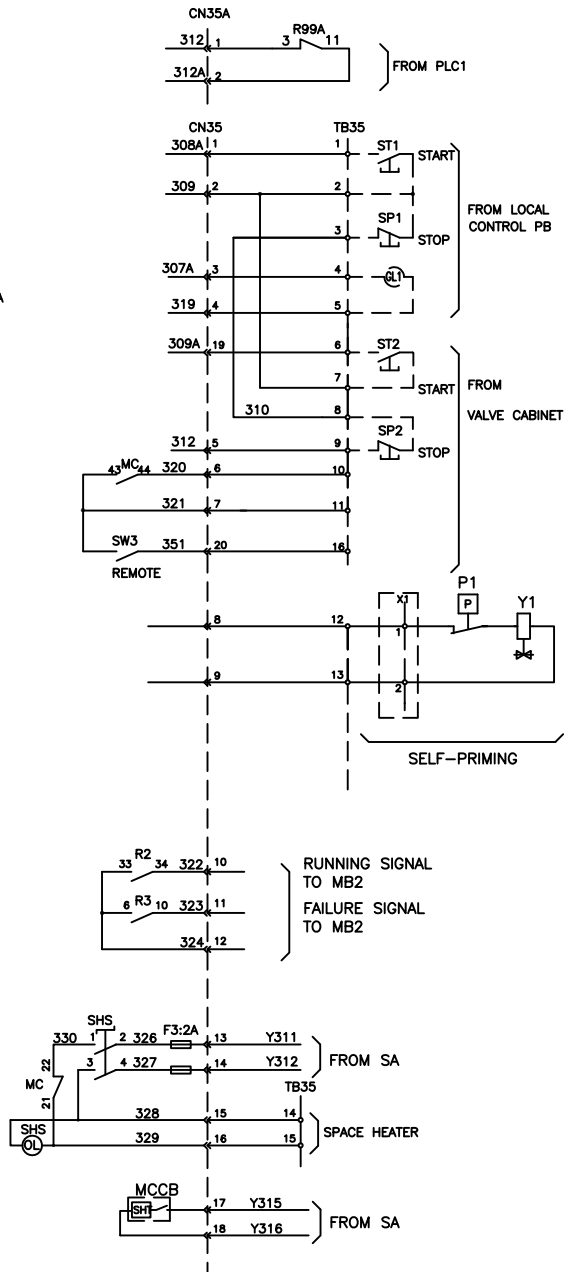
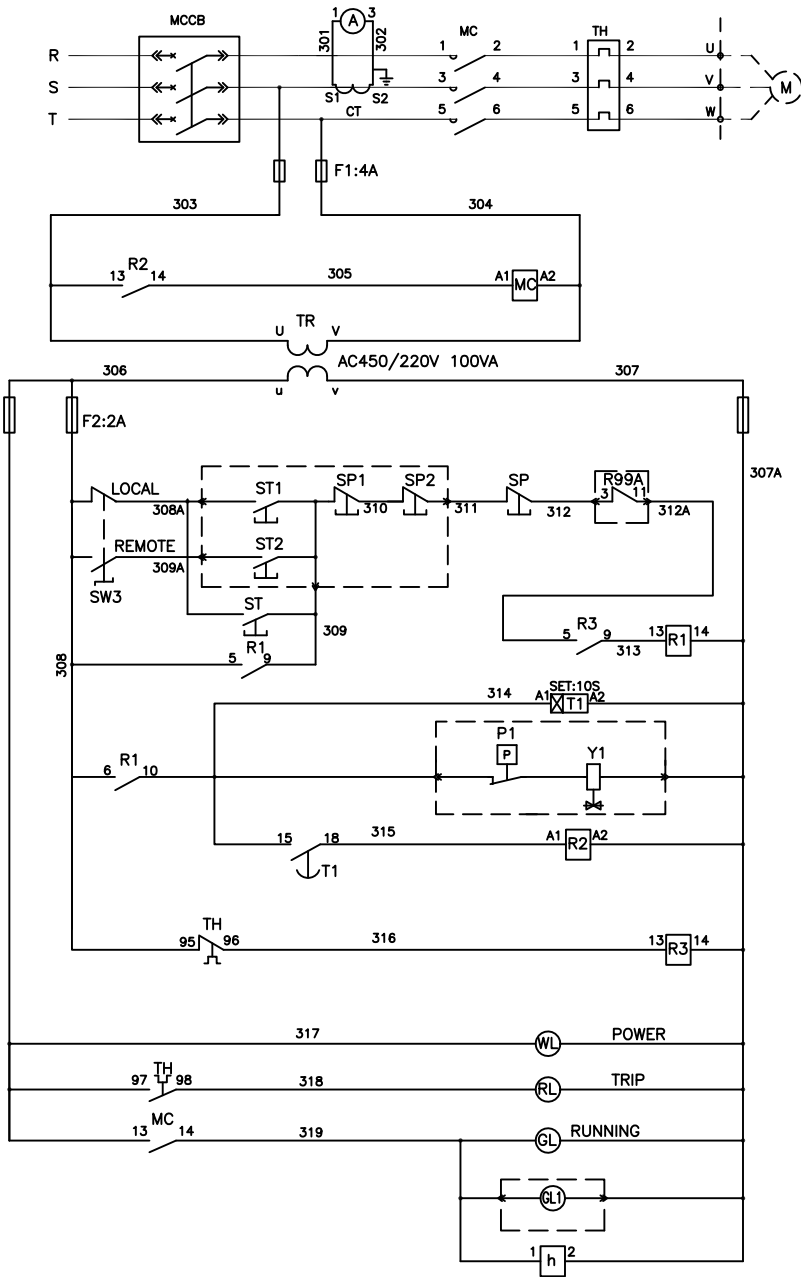

2GSP10

NO.2 BALLAST PUMP

SCHMATIC DIAGRAM

D2GSP10

2-35

A B C D E F G H I



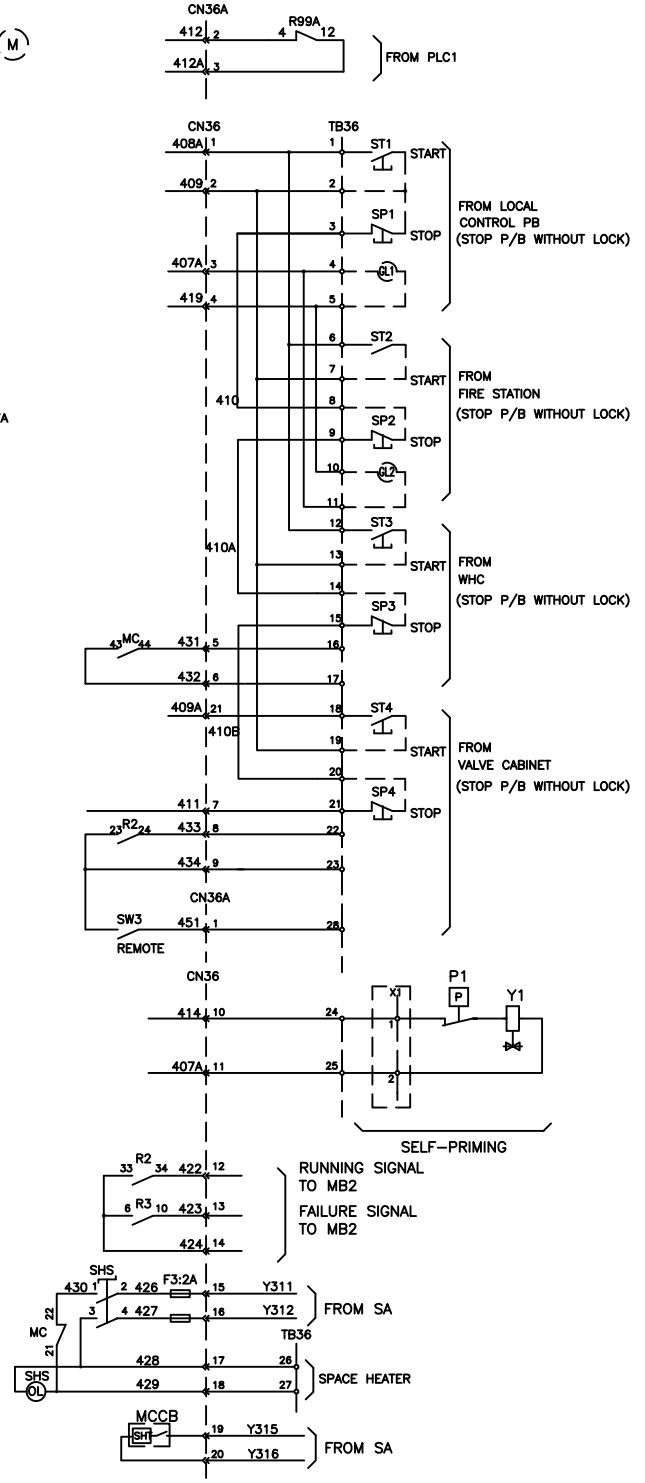
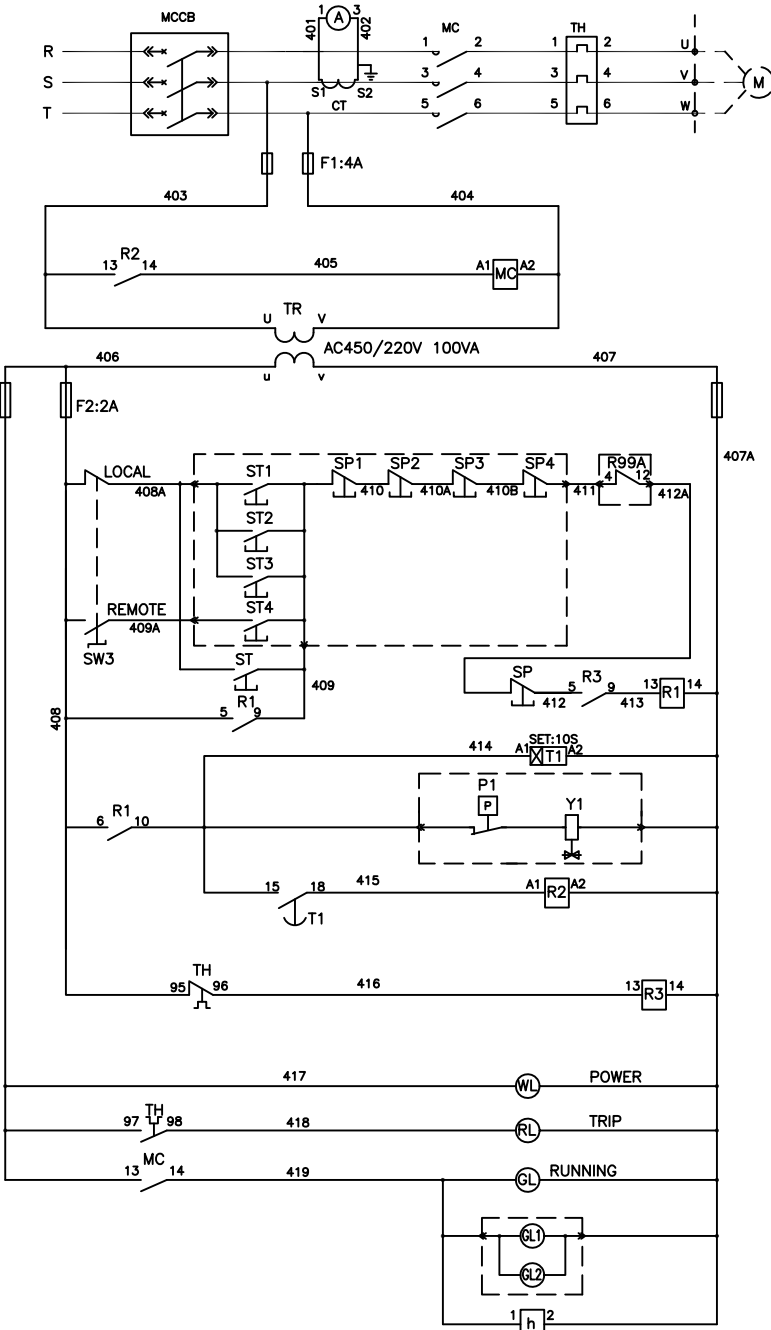

2GSP11 | NO.2 FIRE BILGE & G.S. PUMP

A B C D E F G H I



SCHEMATIC DIAGRAM

D2GSP11

2-36

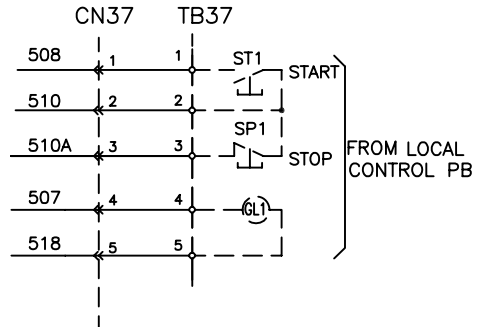
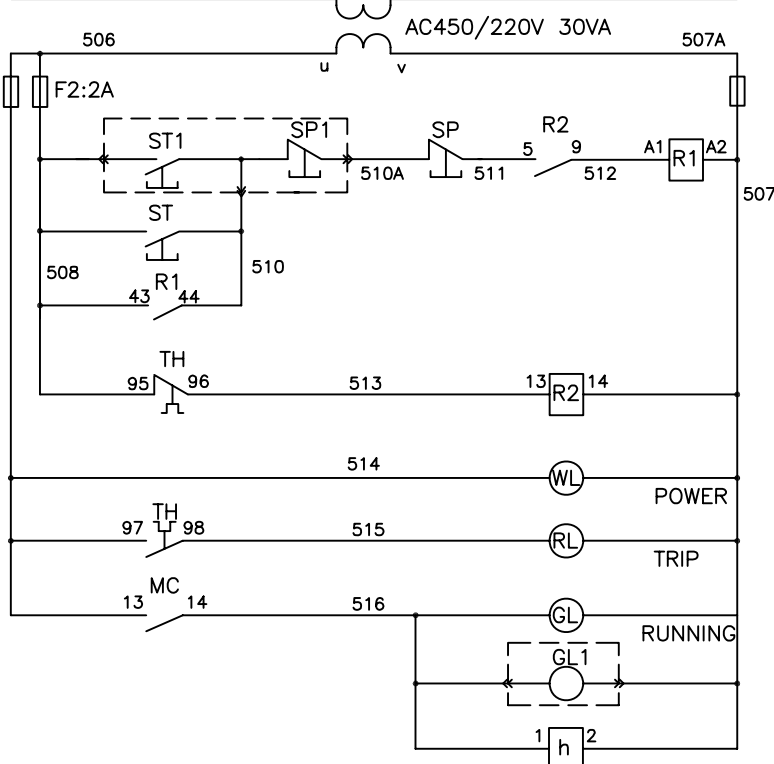
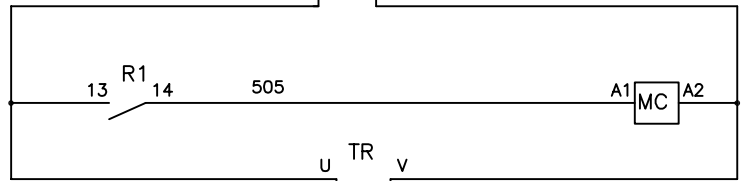
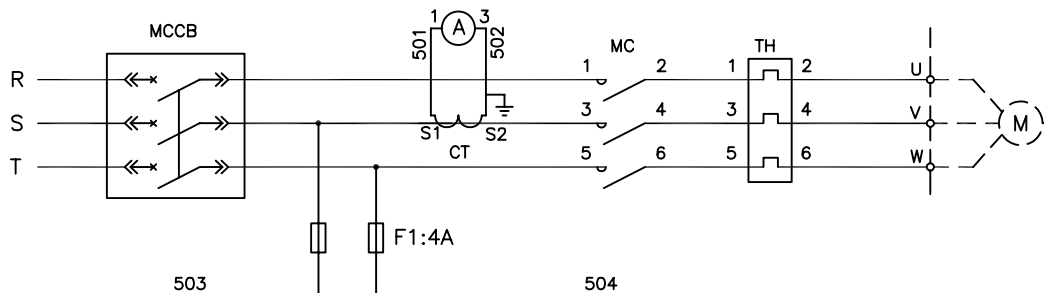

2GSP12	SPARE
--------	-------

A	B	C	D	E	F	G	H	I
---	---	---	---	---	---	---	---	---



SCHMATIC DIAGRAM

D2GSP12
2-37

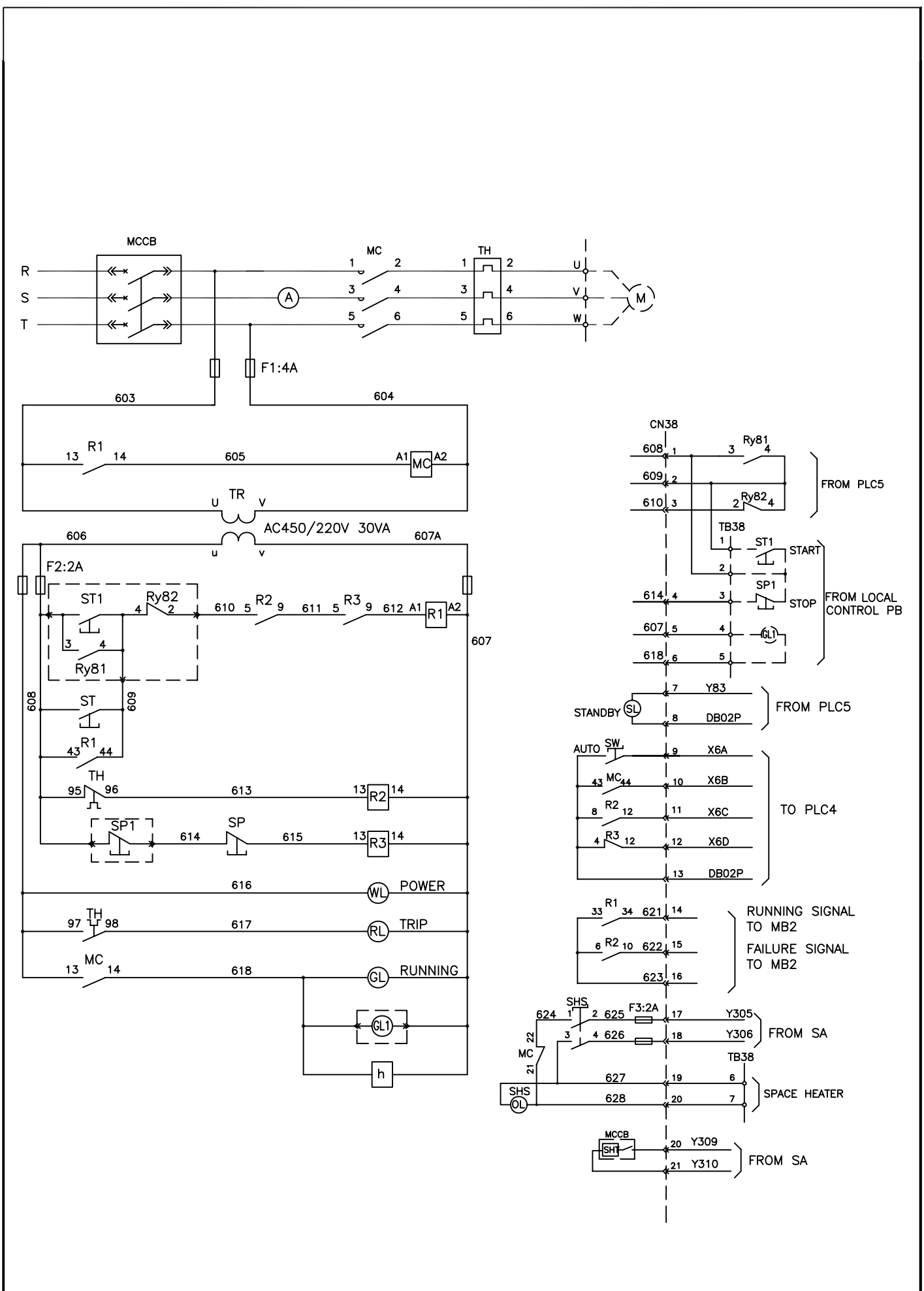

2GSP13 NO.2 STERN TUBE LUB. OIL PUMP

A B C D E F G H I



SCHMATIC DIAGRAM

D2GSP13
2-38

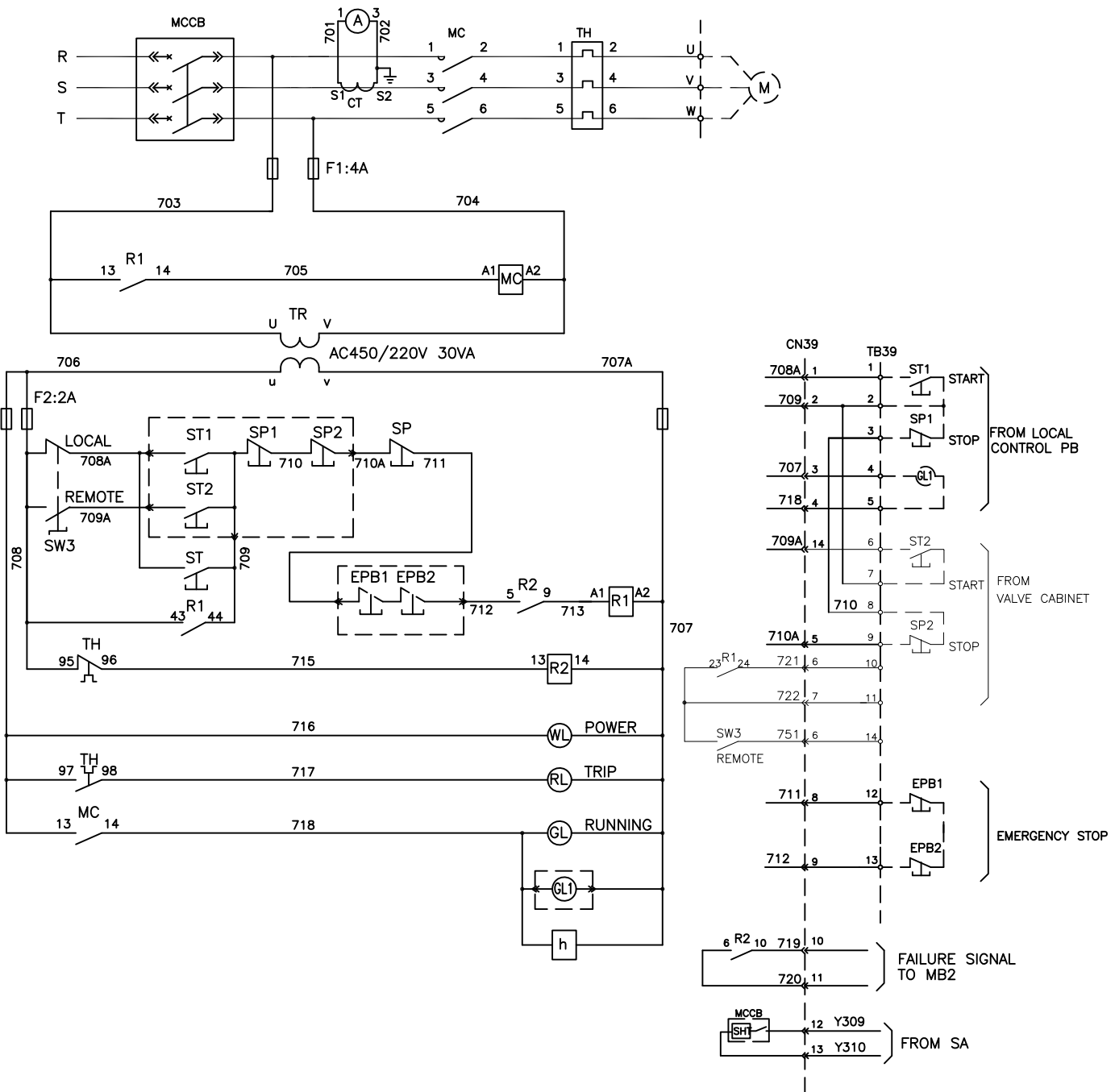

2GSP14

D.O. TRANSFER PUMP

A B C D E F G H I



SCHEMATIC DIAGRAM

D2GSP14

2-39

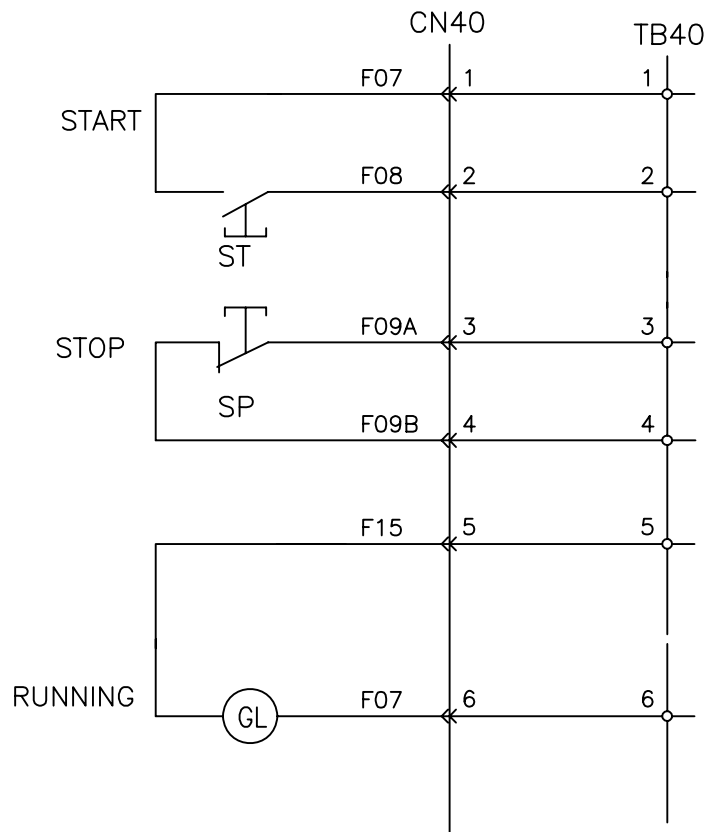

2GSP15 STEERING GEAR ROOM SUPPLY FAN

A B C D E F G H I



SCHEMATIC DIAGRAM

D2GSP15
2-40

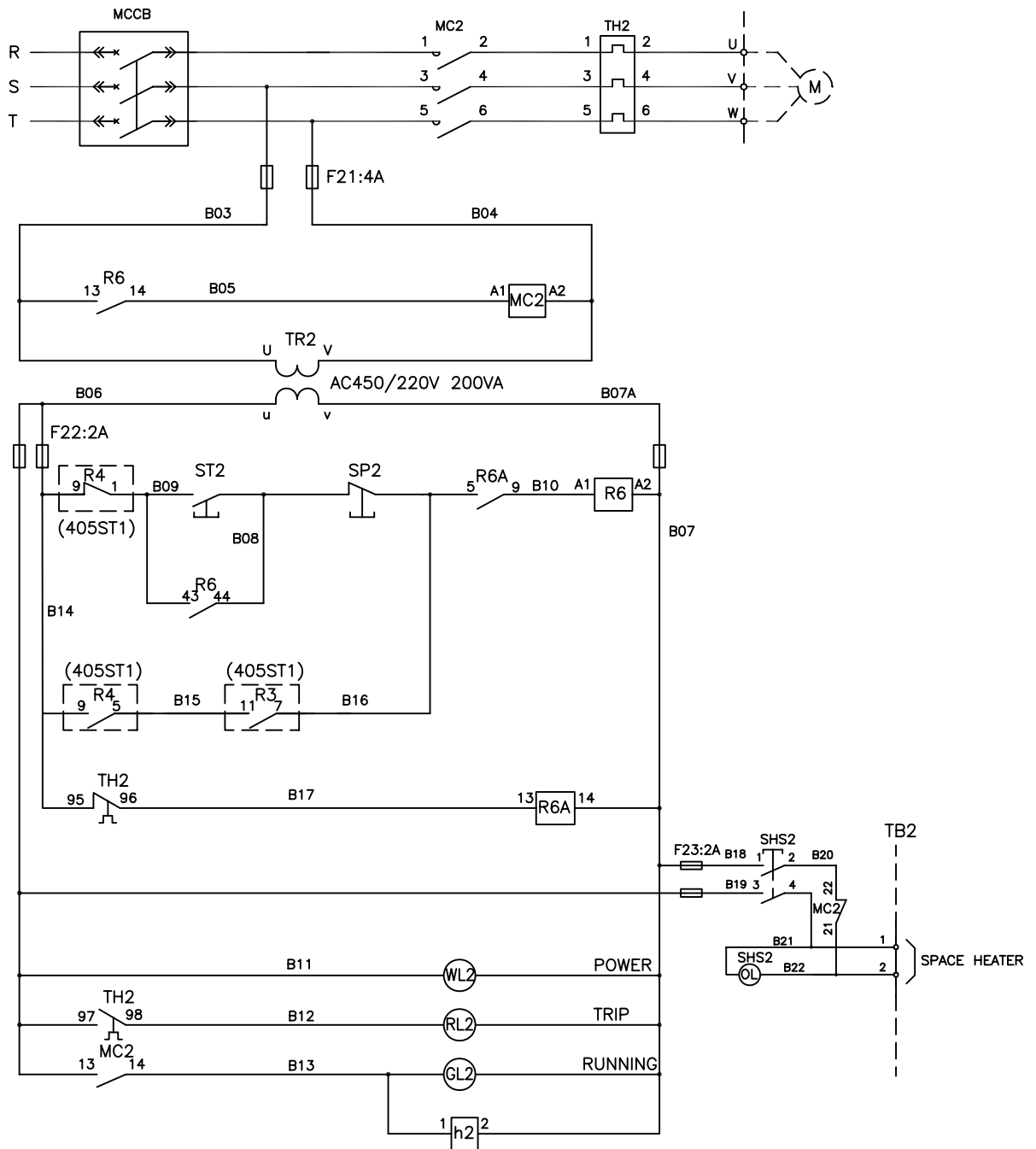

TB2	QT.2	
NO.	1	2
	SPACE HEATER	
CABLE	405P6-2	

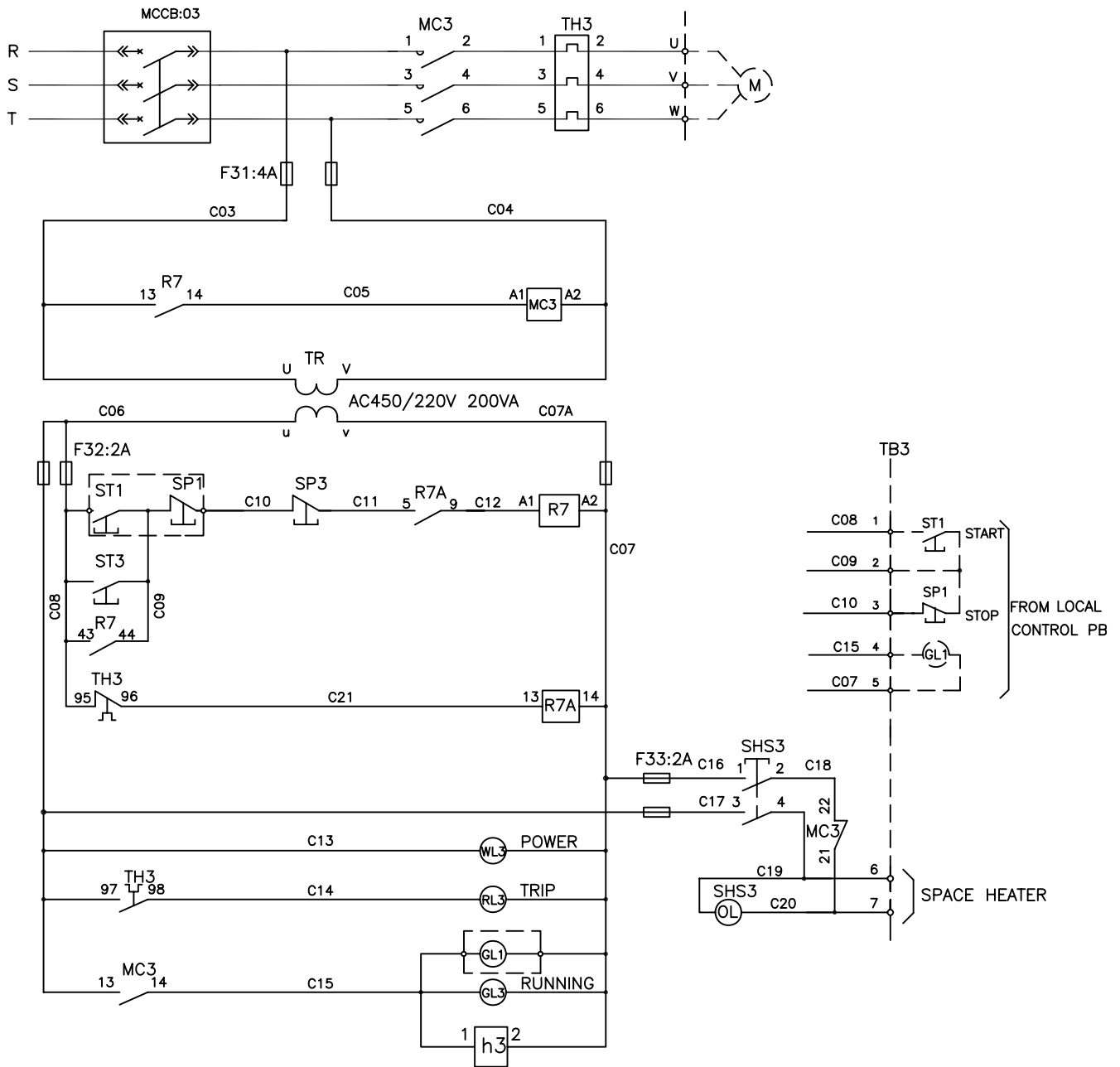

TB3 QT.7

TERMINAL No.	1	2	3	4	5	6	7
	FROM LOCAL CONTROL PB			SPACE HEATER			
CABLE No.	405P1			405P1-2			

NO.1 A/C COOLING FW BOOSTER PUMP

SCHEMATIC DIAGRAM

405ST3(03)
2-43

A B C D A F G H I



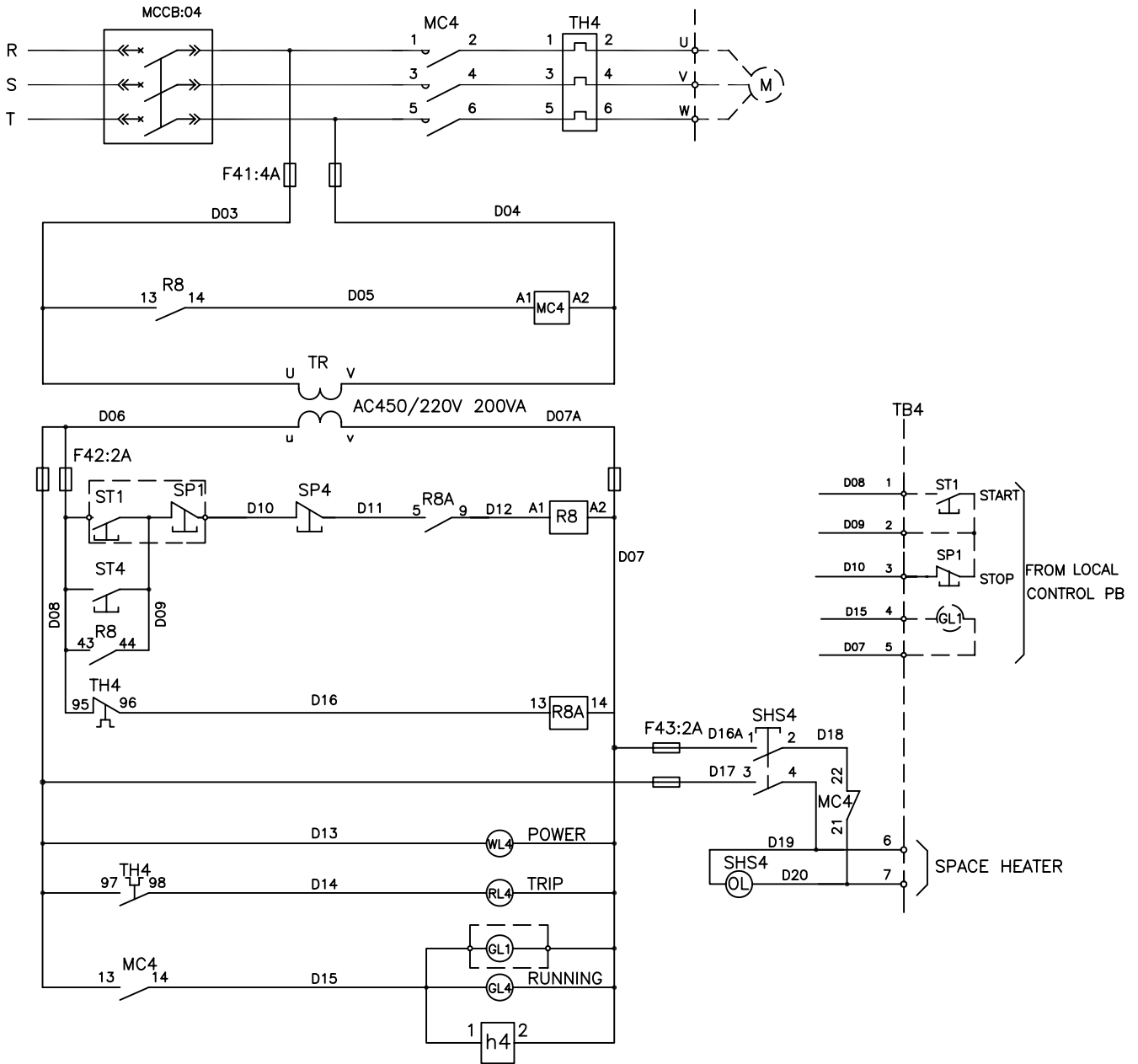

TB4 QT.7

TERMINAL No.	1	2	3	4	5	6	7
	FROM LOCAL CONTROL PB			SPACE HEATER			
CABLE No.	405P2			405P2-2			

NO.2 A/C COOLING FW BOOSTER PUMP

SCHMATIC DIAGRAM

405ST4(04)
2-44

A B C D A F G H I



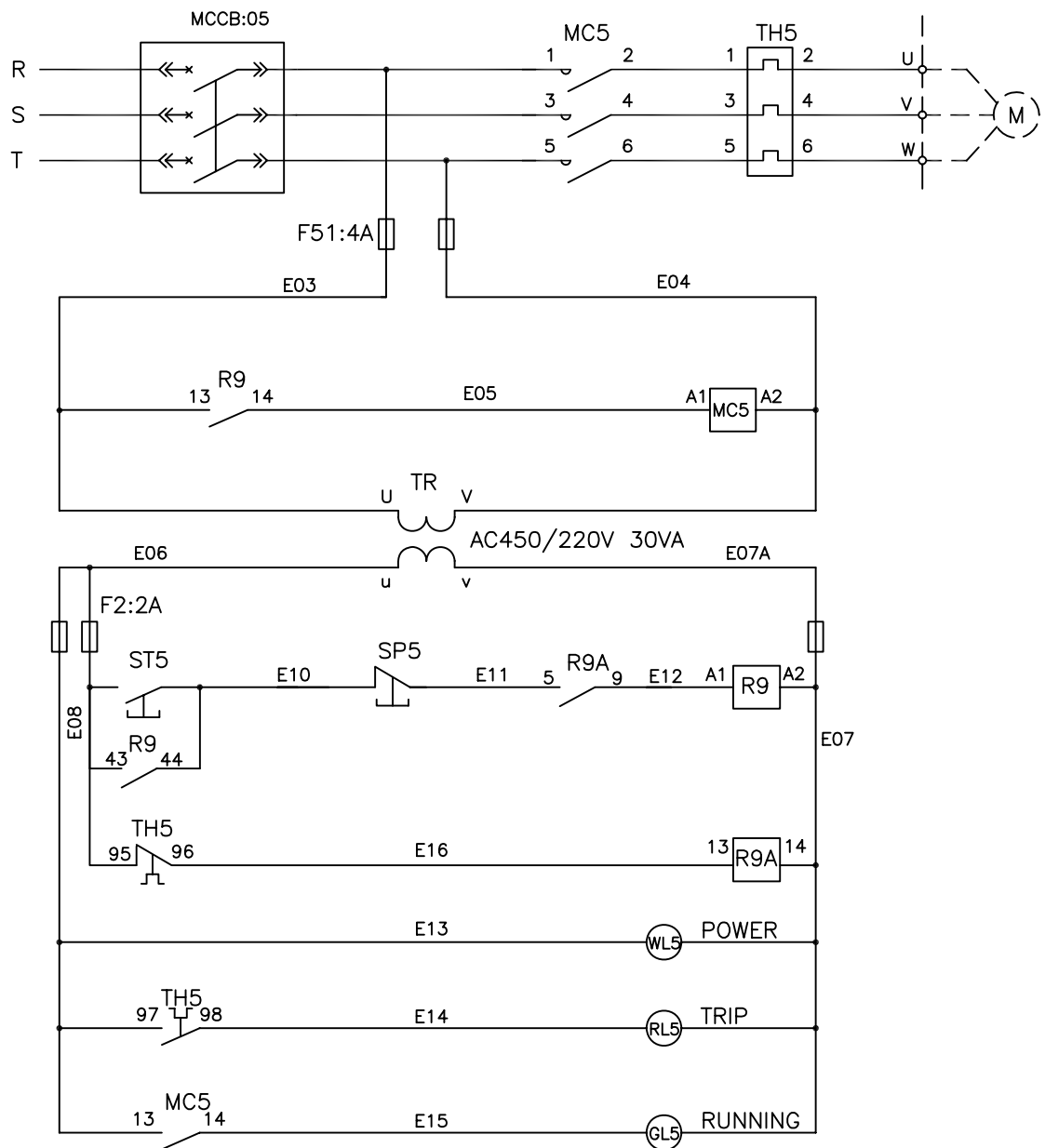

HOT WATER CIRC. PUMP

SCHEMATIC DIAGRAM

405ST5(05)
2-45

A B C D A F G H I



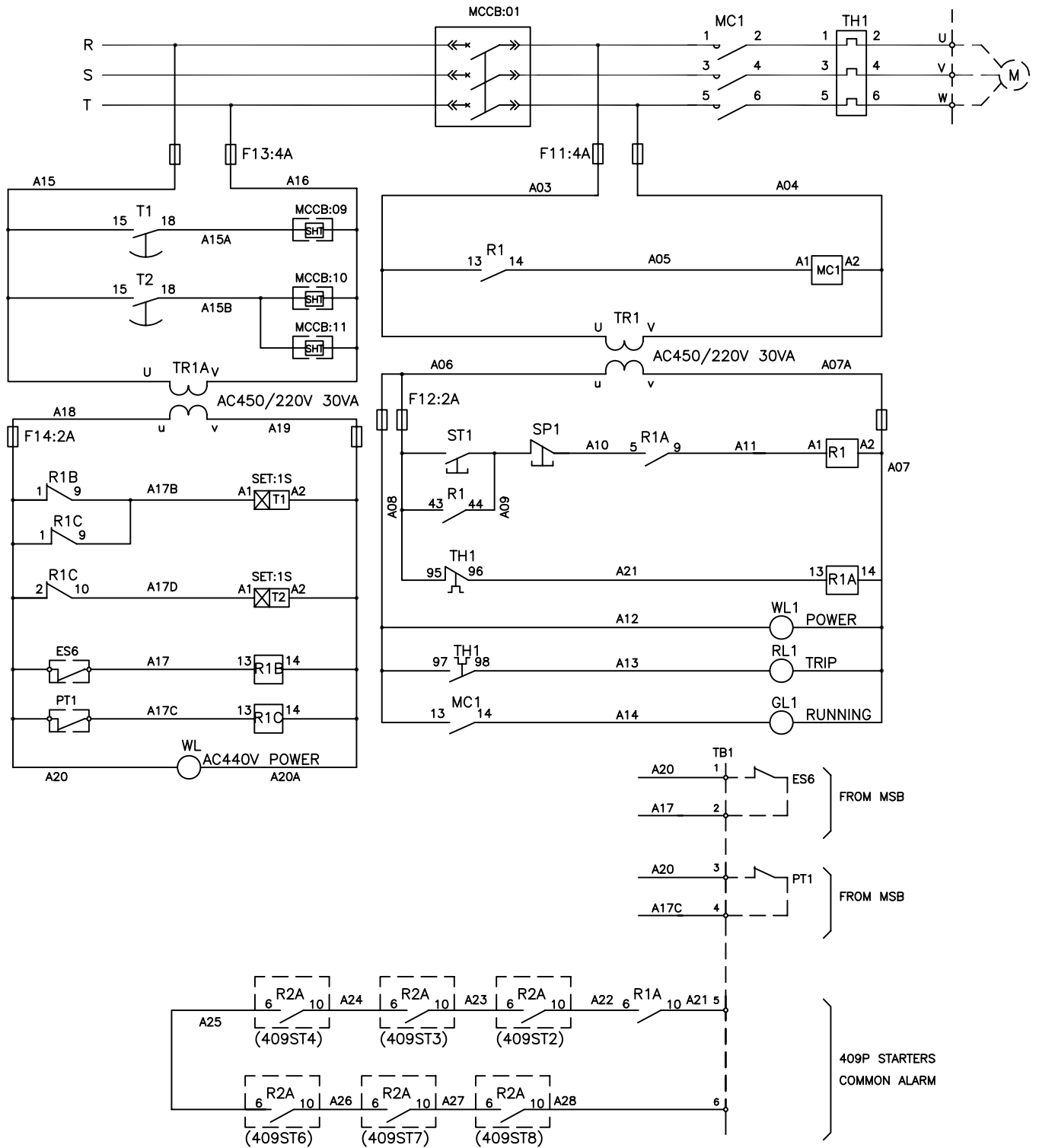

TB1 QT.6

TERMINAL No.	1	2	3	4	5	6
	ES6 FROM MSB		PT1 FROM MSB		409P STARTERS COMMON ALARM	
CABLE No.	ES-409		ES-409		409P-A	

SANITARY EXH. FAN FOR ACC.

SCHMATIC DIAGRAM

409ST1(01)

2-46

A B C D A F G H I



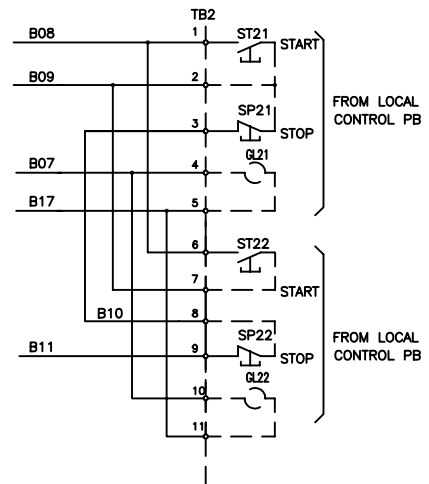
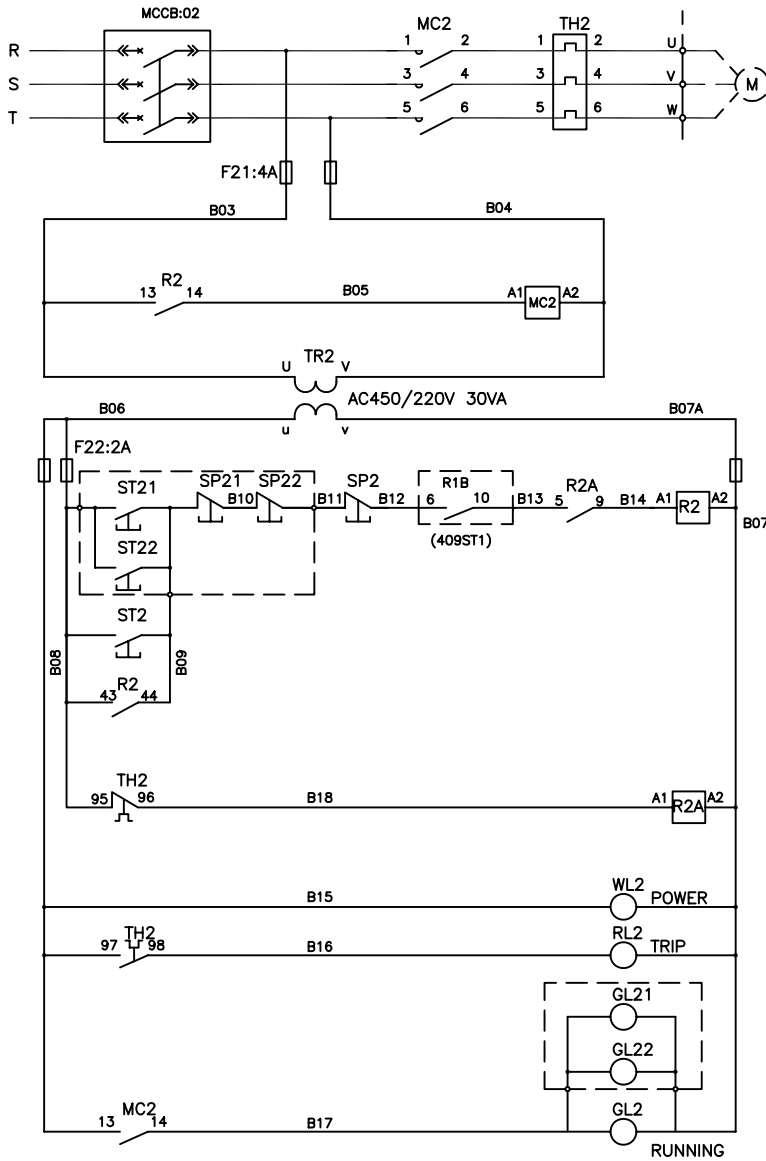

TB2 QT.11

TERMINAL No.	1	2	3	4	5	6	7	8	9	10	11
	FROM LOCAL CONTROL PB					FROM LOCAL CONTROL PB					
CABLE No.	409P2-1					409P2-2					

GALLEY SUPPLY FAN

SCHEMATIC DIAGRAM

409ST2(02)

2-47

A B C D A F G H I



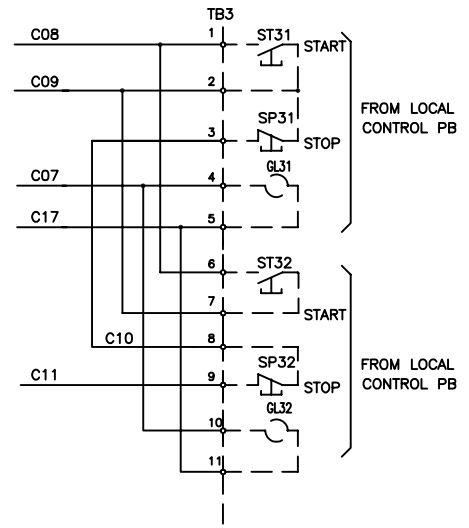
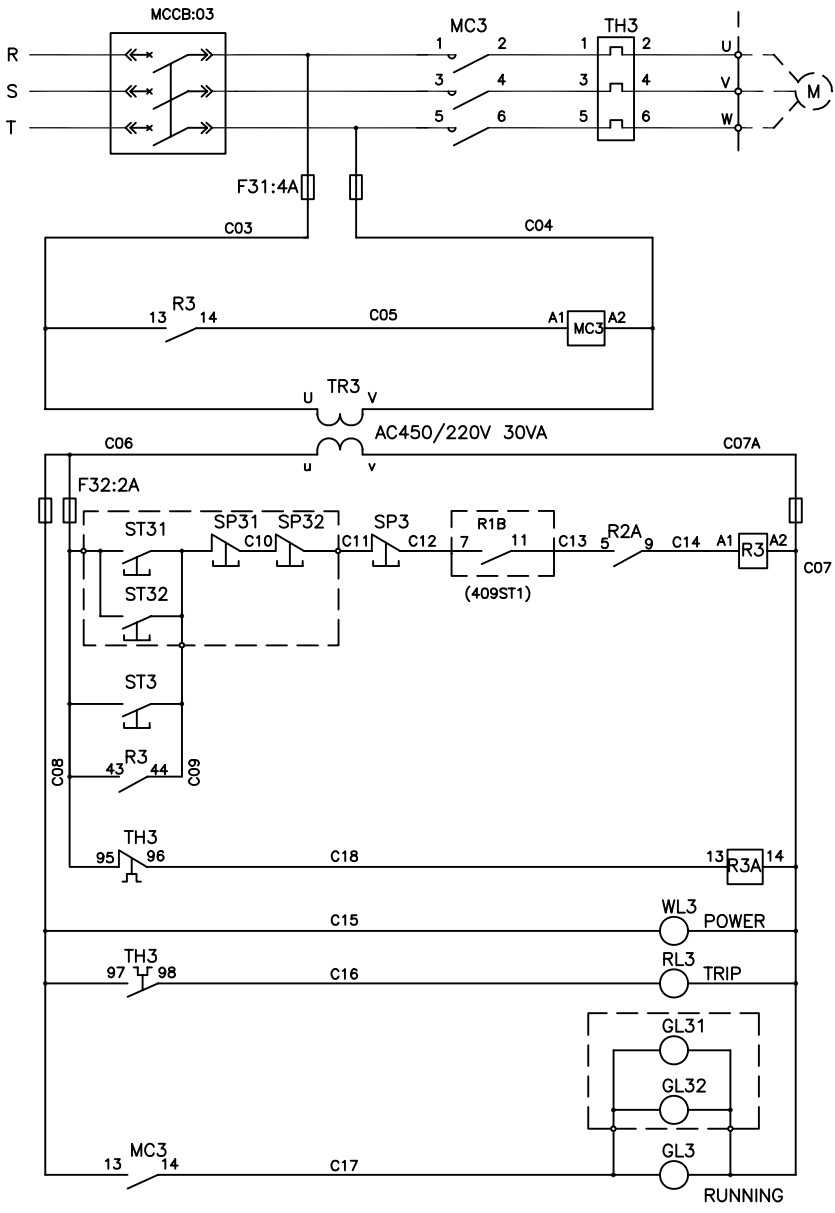

TB3 QT.11

TERMINAL No.	1	2	3	4	5	6	7	8	9	10	11
	FROM LOCAL CONTROL PB					FROM LOCAL CONTROL PB					
CABLE No.	409P3-1					409P3-2					

GALLEY EXH. FAN(03)

SCHEMATIC DIAGRAM

409ST3(03)

2-48

A B C D A F G H I



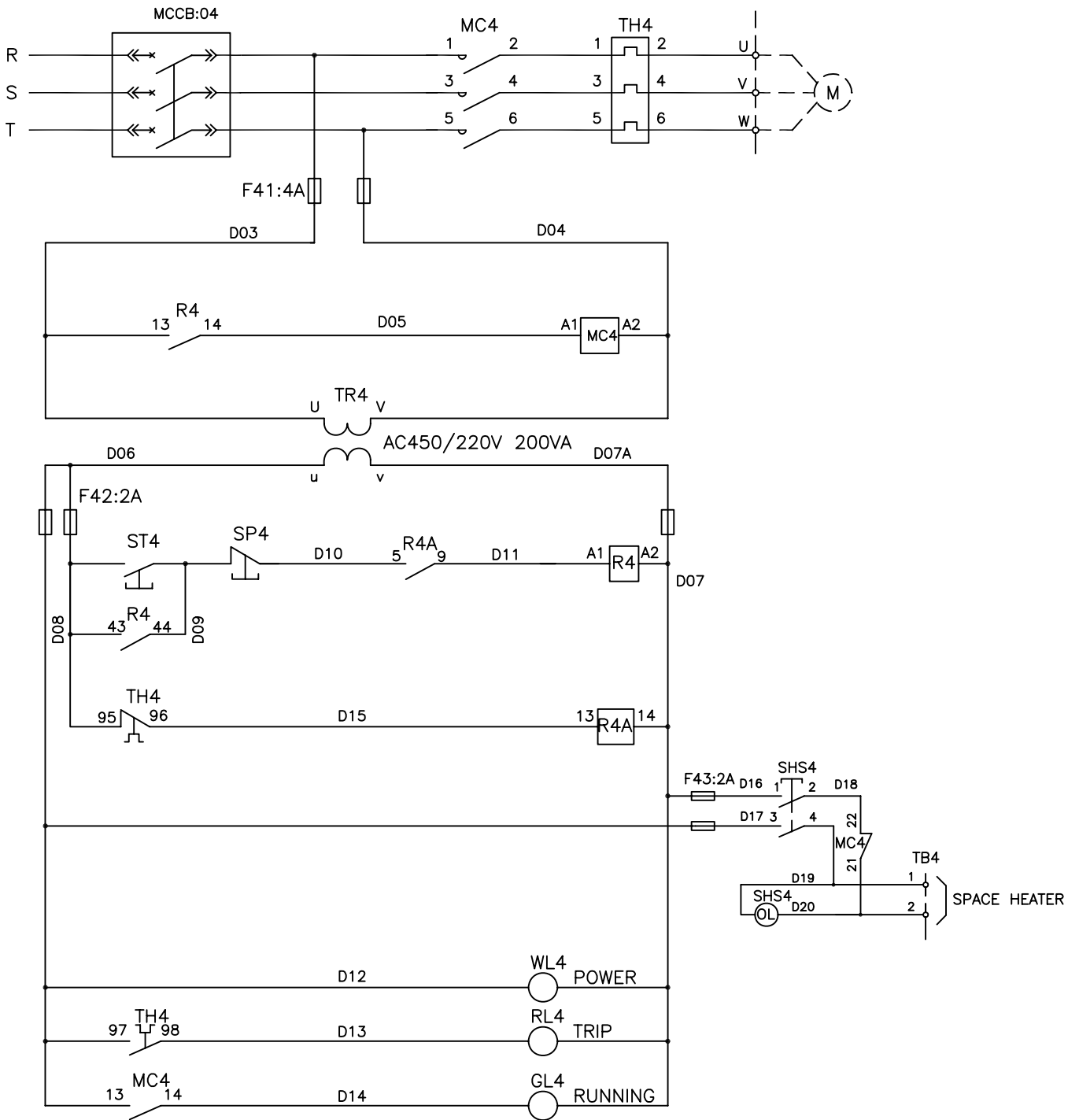

BATTERY ROOM EXH. FAN(04)

SCHEMATIC DIAGRAM

409ST4(04)

2-49

A B C D A F G H I



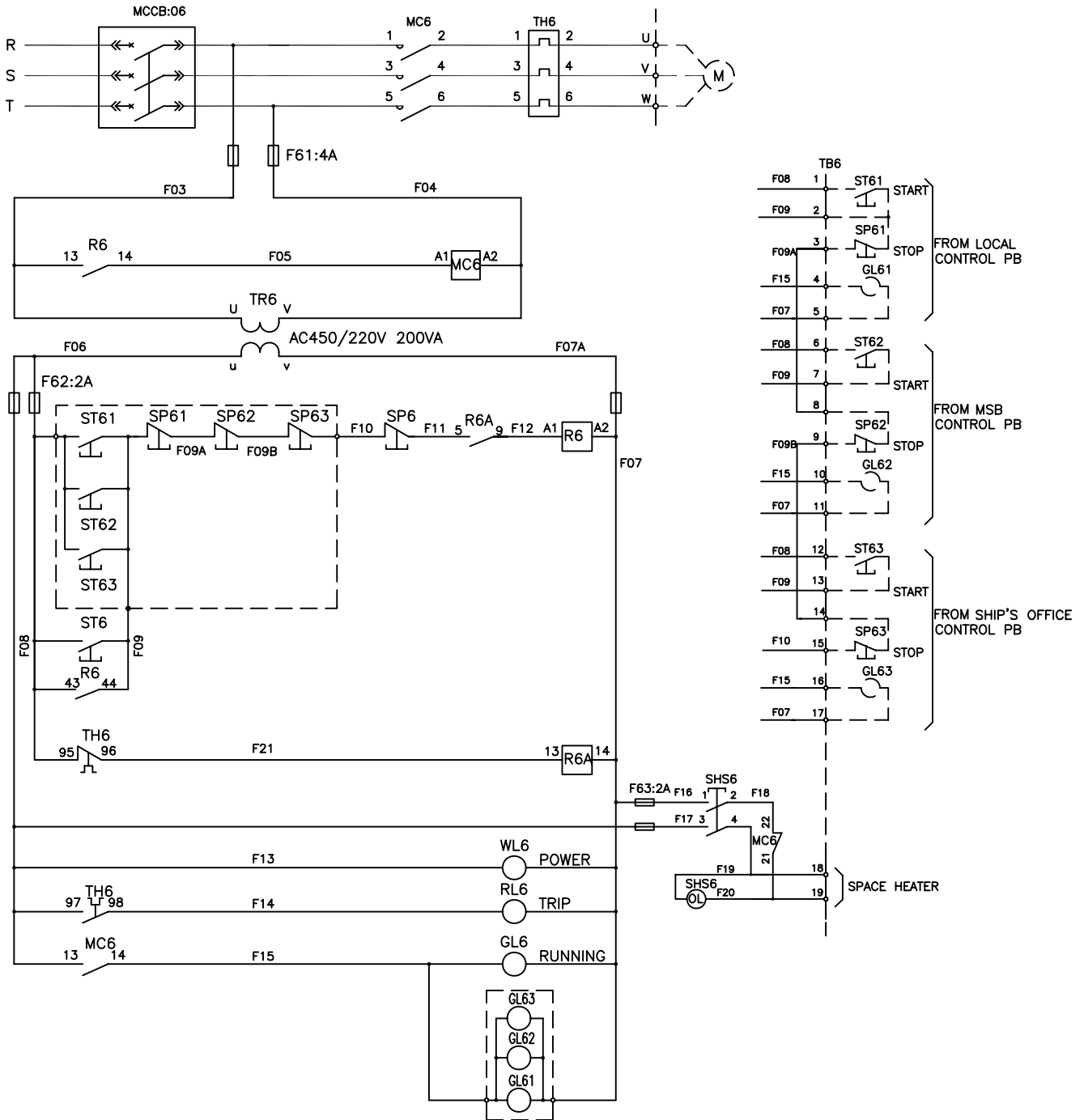

TB6 QT.19

NO.	1	2	3	4	5	6	7	8	9	10	11	12	13	14	15	16	17	18	19
	LOCAL CONTROL PUSHBUTTON BOX					MSB CONTROL PUSHBUTTON BOX					SHIP'S OFFICE PUSHBUTTON BOX					SPACE HEATER			
CABLE	409P9-1					409P9-3					409P9-4					409P1-2			

STEERING GEAR ROOM SUPPLY FAN

SCHEMATIC DIAGRAM

409ST6(06)

2-50

A B C D E F G H I



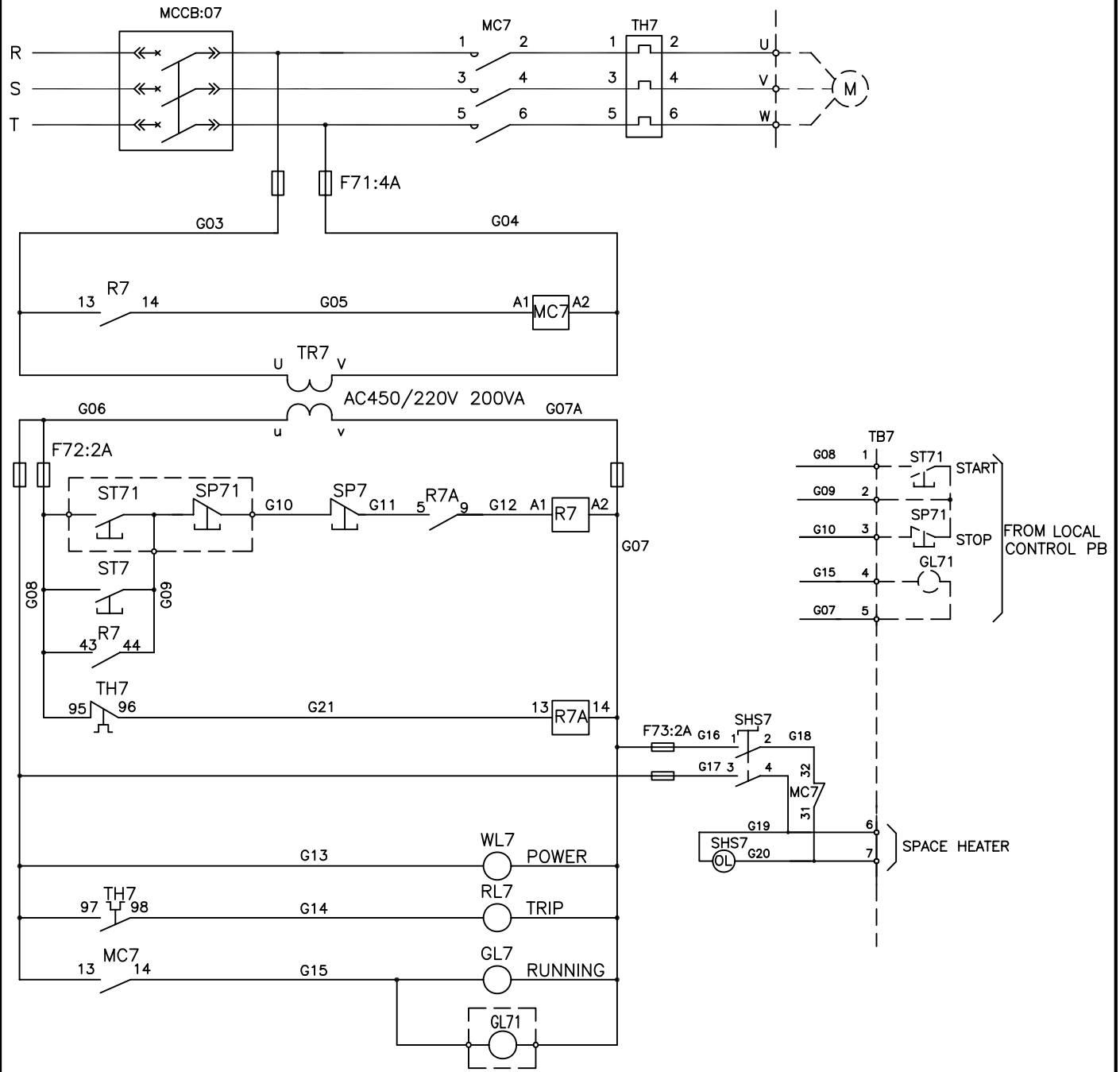

TB7

QT.7

NO.	1	2	3	4	5	6	7
	LOCAL CONTROL PUSHBUTTON BOX					SPACE HEATER	
CABLE	409P10-2					409P10-1	

CO2 ROOM EXH.FAN

SCHMATIC DIAGRAM

409ST7(07)

2-51

A B C D E F G H I



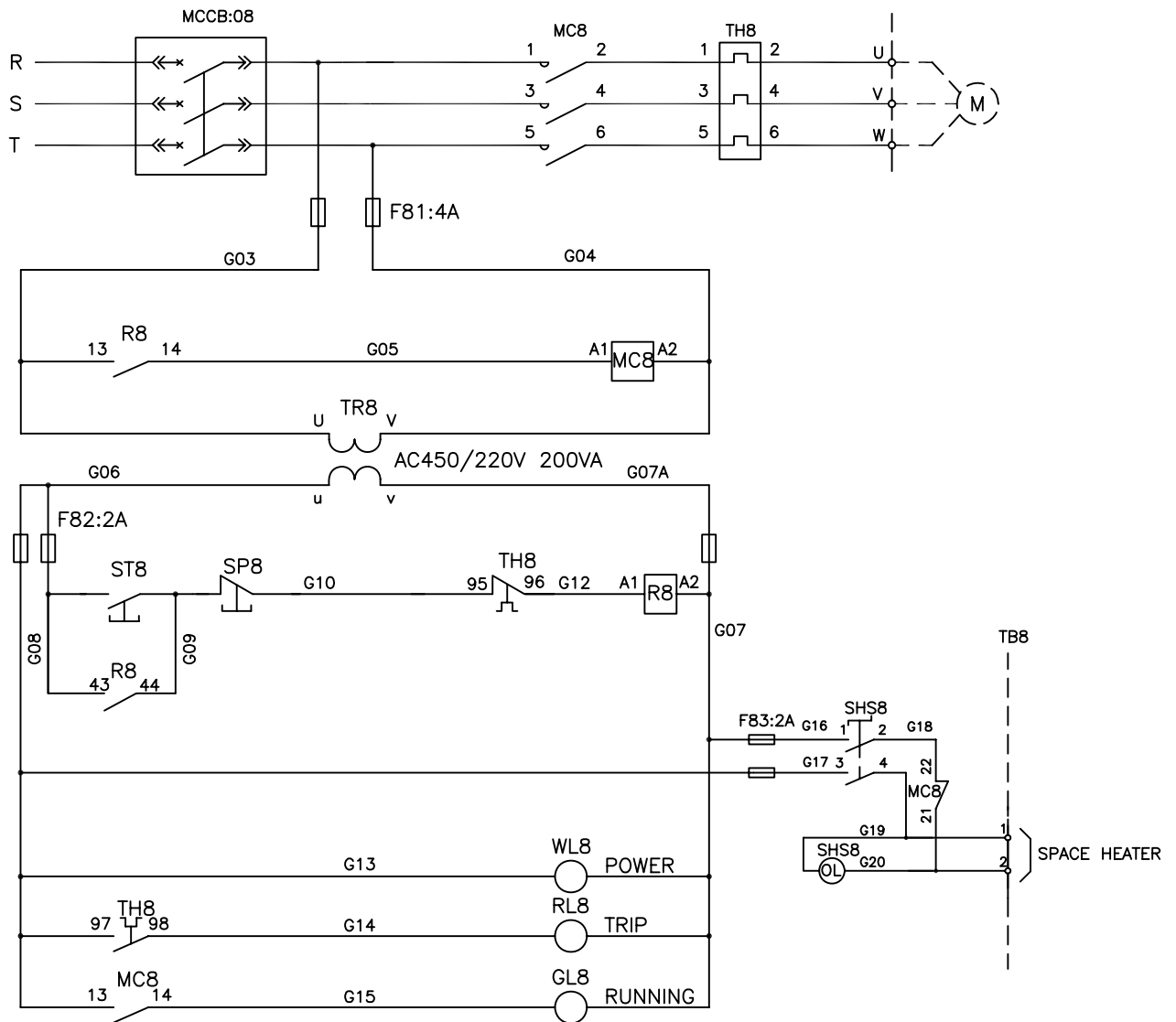

TB8 QT.2

NO.	1	2
	SPACE HEATER	
CABLE	409P11-1	

AIR CON.RM EXH.FAN

SCHEMATIC DIAGRAM

409ST8(08)

2-52

A B C D E F G H I



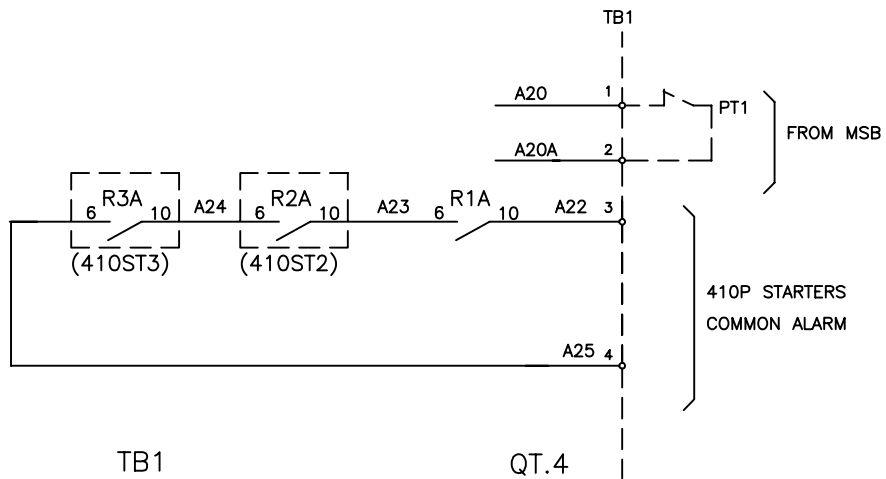
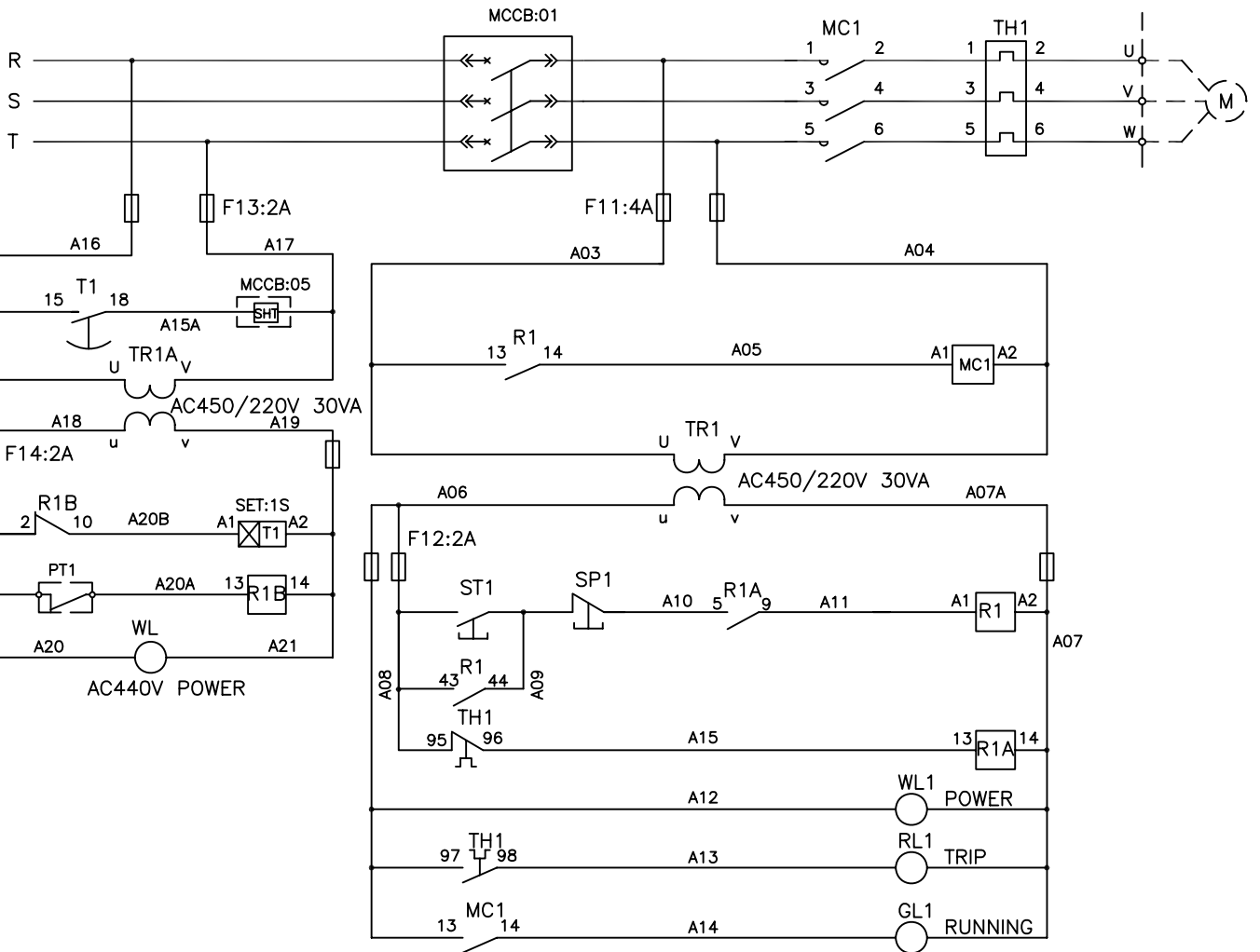

NO.	1	2	3	4
	PT1 FROM MSB		410P STARTERS COMMON ALARM	
CABLE	PT-410		410P-A	

ENGINEER'S WORKSHOP EXH.FAN

SCHEMATIC DIAGRAM

410ST1(01)

2-53

A B C D E F G H I



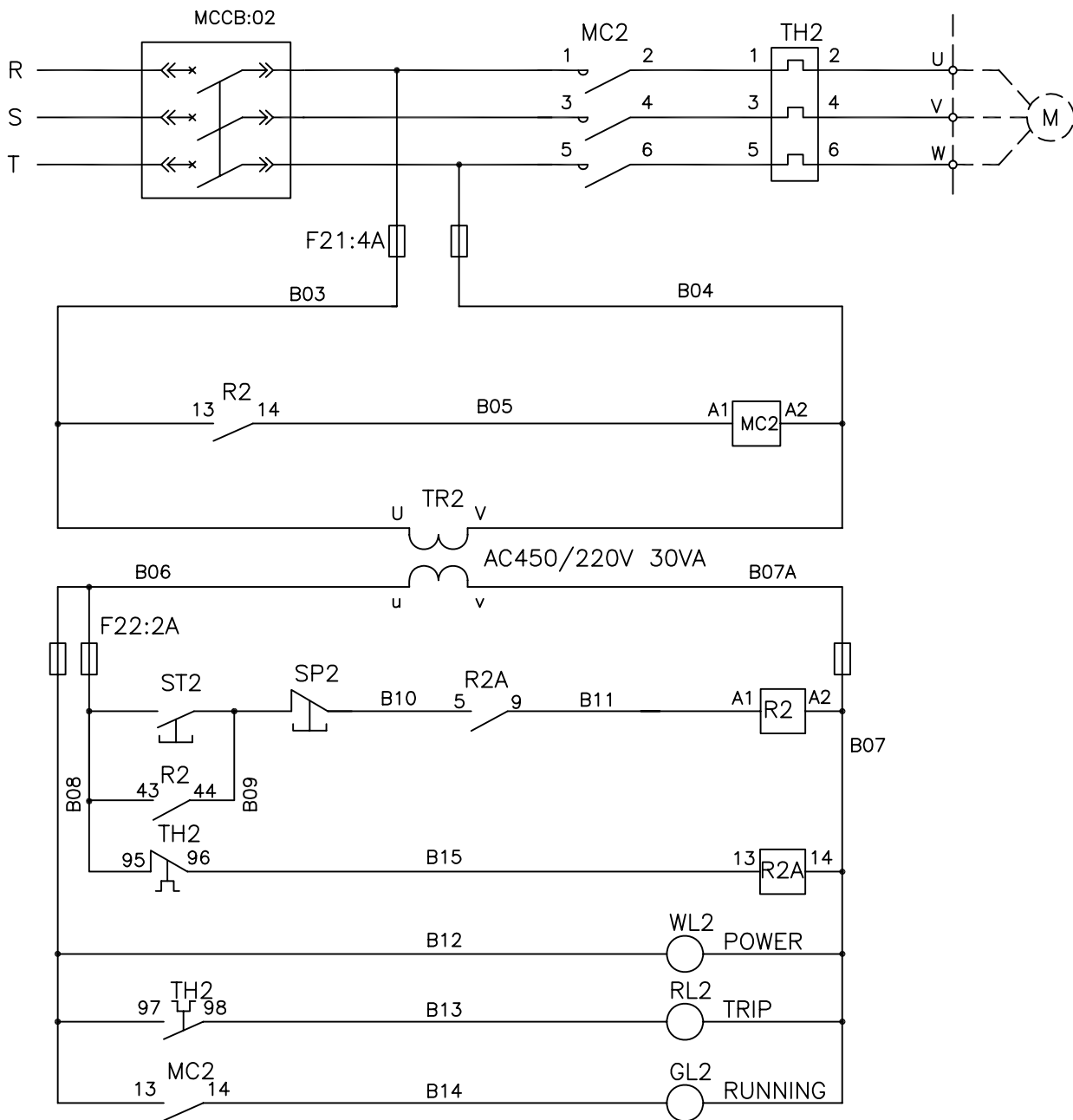

WELDING SPACE EXH.FAN

SCHEMATIC DIAGRAM

410ST2(02)

2-54

A B C D E F G H I



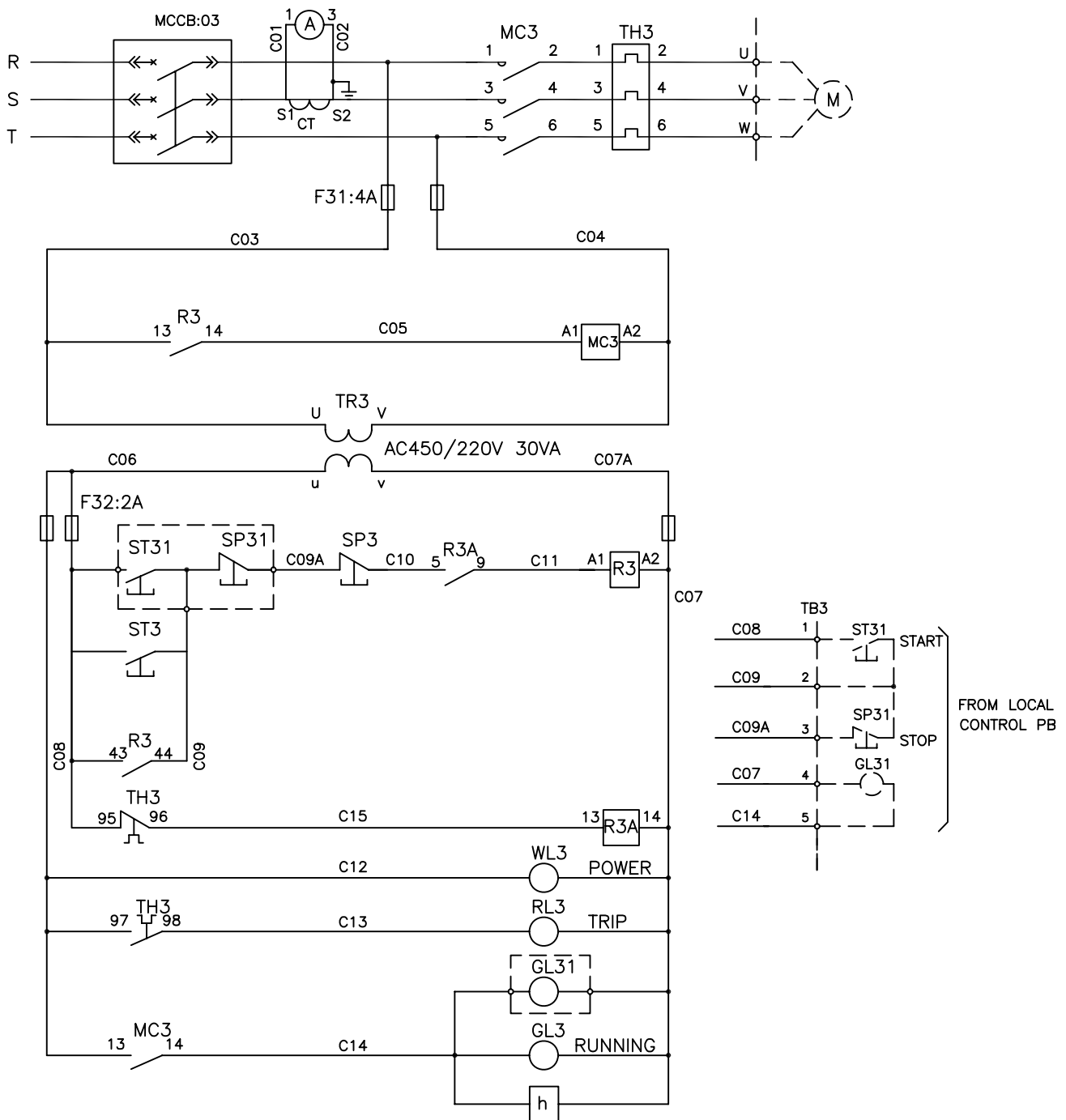

PURIFIER SPACE EXH.FAN

SCHEMATIC DIAGRAM

410ST3(03)

2-55

A B C D E F G H I



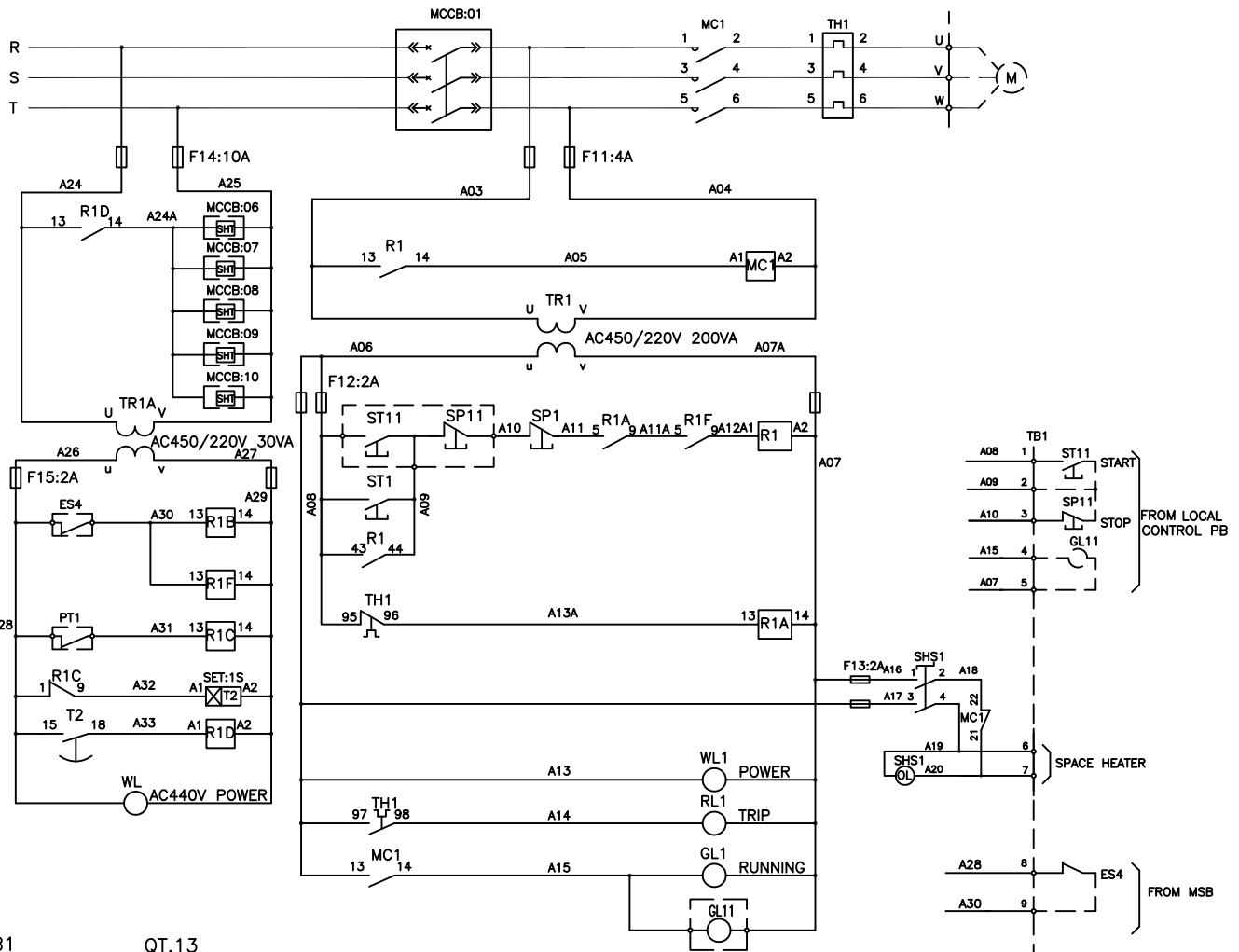

TB1 QT.13

NO.	1	2	3	4	5	6	7	8	9	10	11	12	13
	LOCAL CONTROL PUSHBUTTON BOX				SPACE HEATER		ES4		PT1		COMMON ALARM		
CABLE	411P1-2				411P1-1		ES4-411				411P-A		

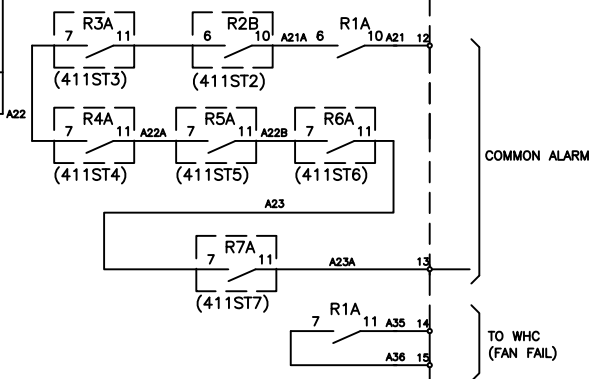

PIPE TUNNEL SUPPLY FAN

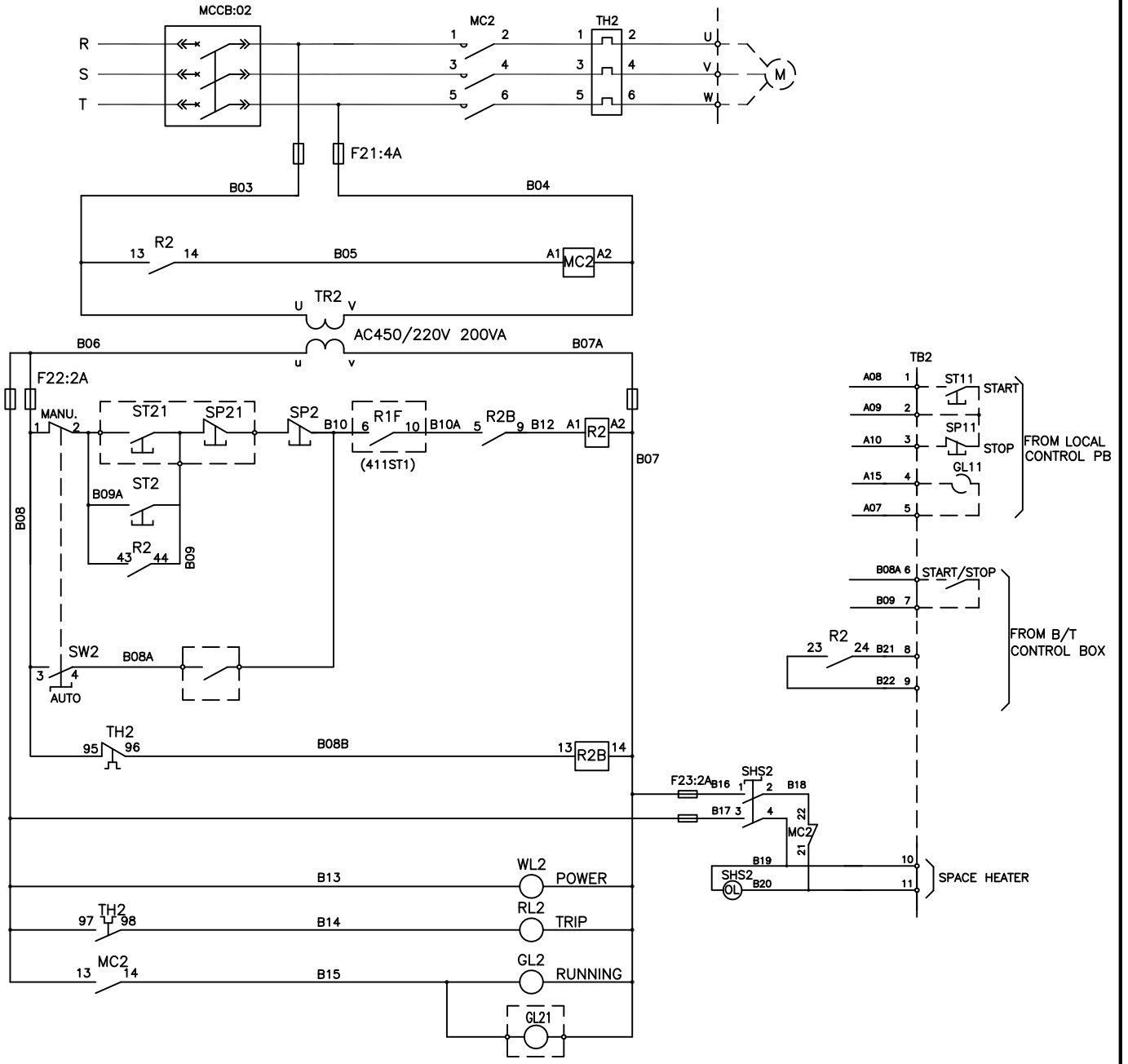

TB2 QT.11

NO.	1	2	3	4	5	6	7	8	9	10	11
	LOCAL CONTROL PUSHBUTTON BOX					FROM B/T CONTROL BOX				SPACE HEATER	
CABLE	411P2-2					BT-21				411P2-1	

BOW THRUSTER & EMERGENCY
FIRE PUMP ROOM SUPPLY FAN

C C C D C F G H I



SCHEMATIC DIAGRAM

411ST2(02)
2-57

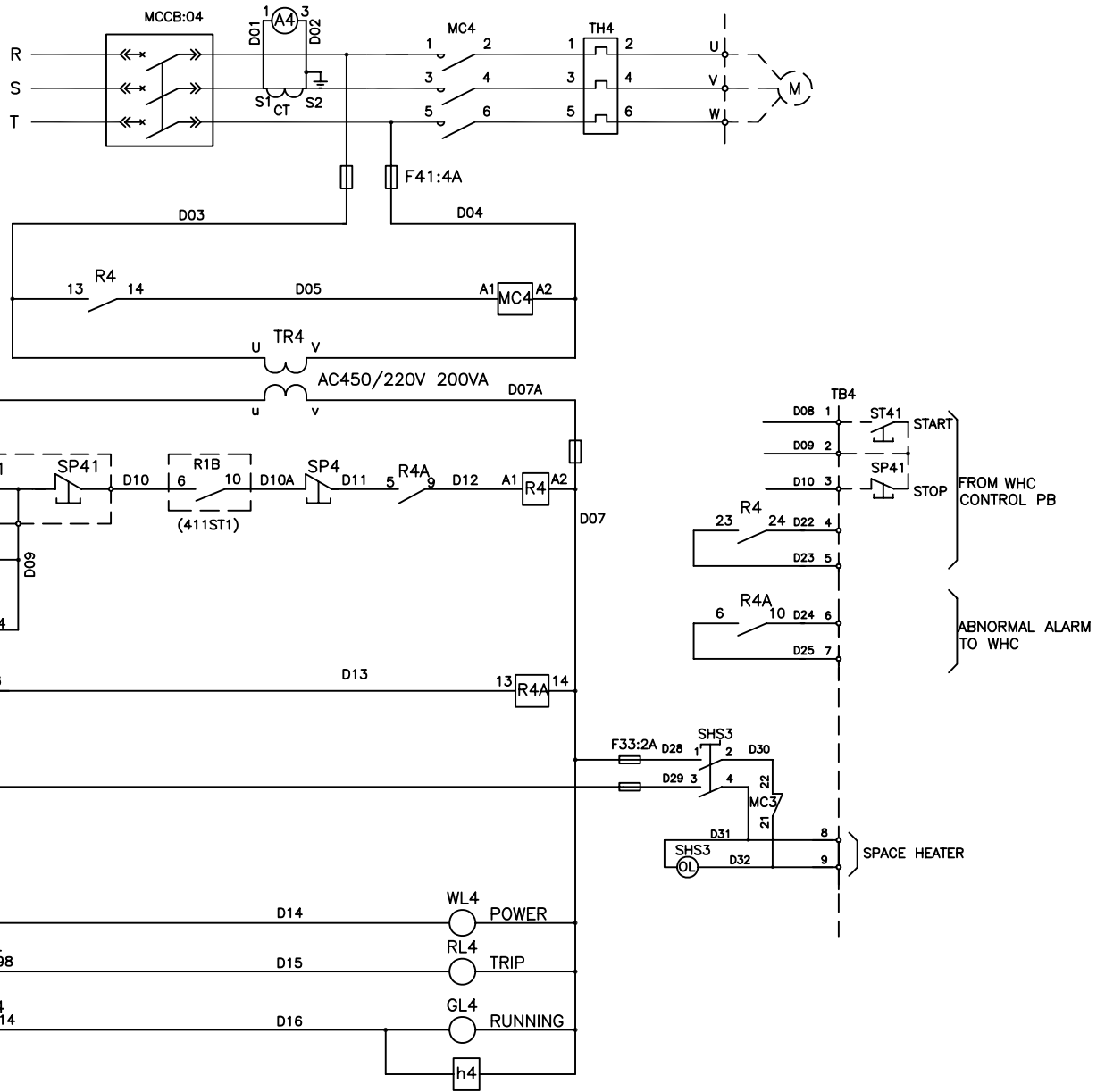

TB4		QT.9								
NO.	1	2	3	4	5	6	7	8	9	
	FROM WHC CONTROL PB AND ABNORMAL ALARM TO WHC							SPACE HEATER		
CABLE	411P4-2							411P4-1		

NO.2 PASSAGEWAY SUPPLY FAN(S)

SCHMATIC DIAGRAM

411ST4(04)

2-59

A B C D E F G H I



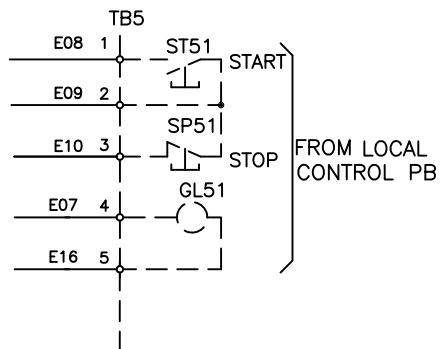
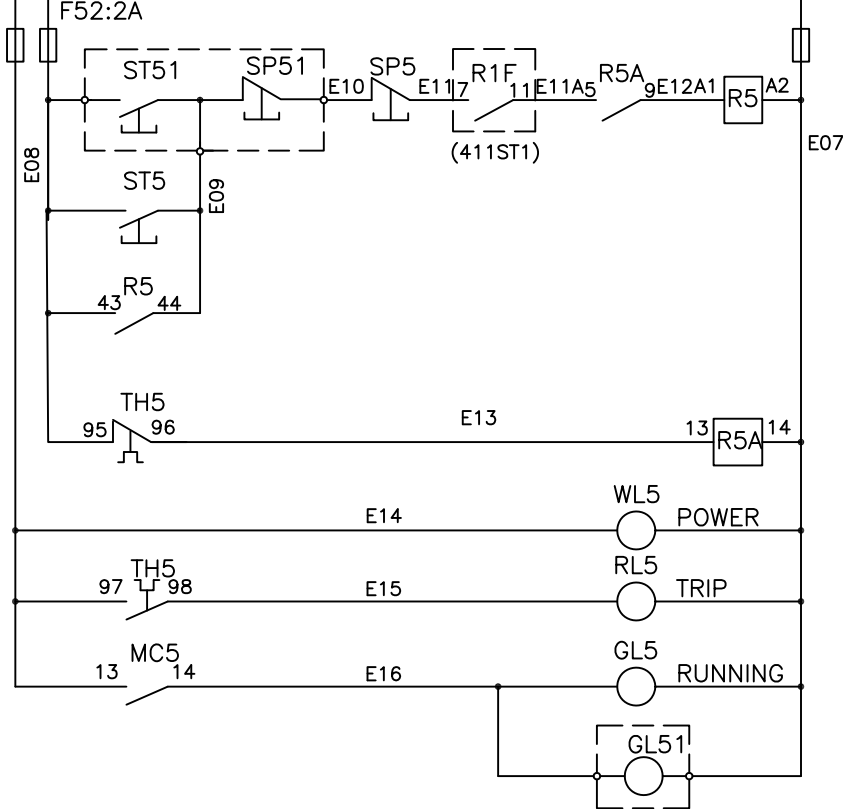
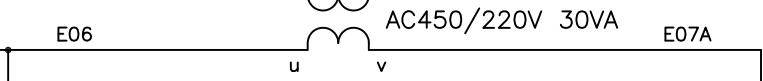
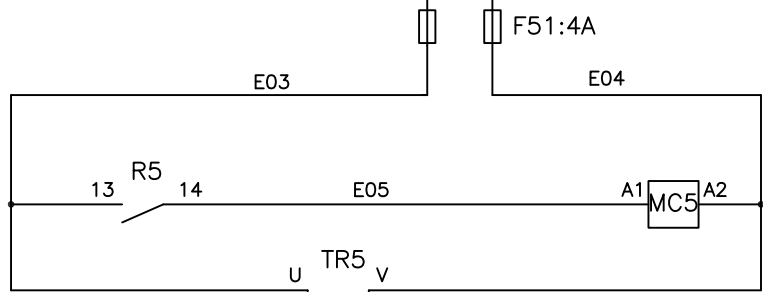
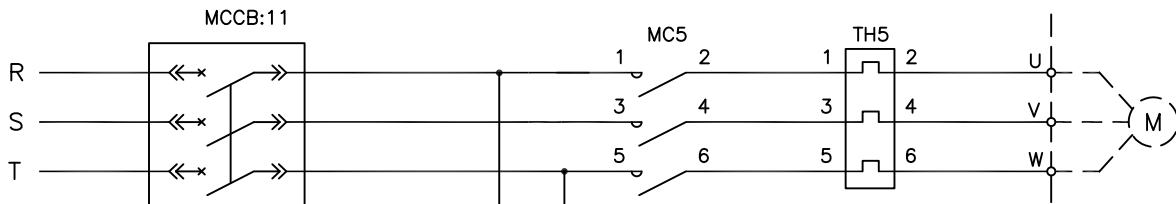

TB5		QT.5				
NO.	1	2	3	4	5	
	LOCAL CONTROL PUSHBUTTON BOX					
CABLE	411P11-5					

PAINT ROOM EXH. FAN

A B C D E F G H I



SCHEMATIC DIAGRAM

411ST5(11)
2-60

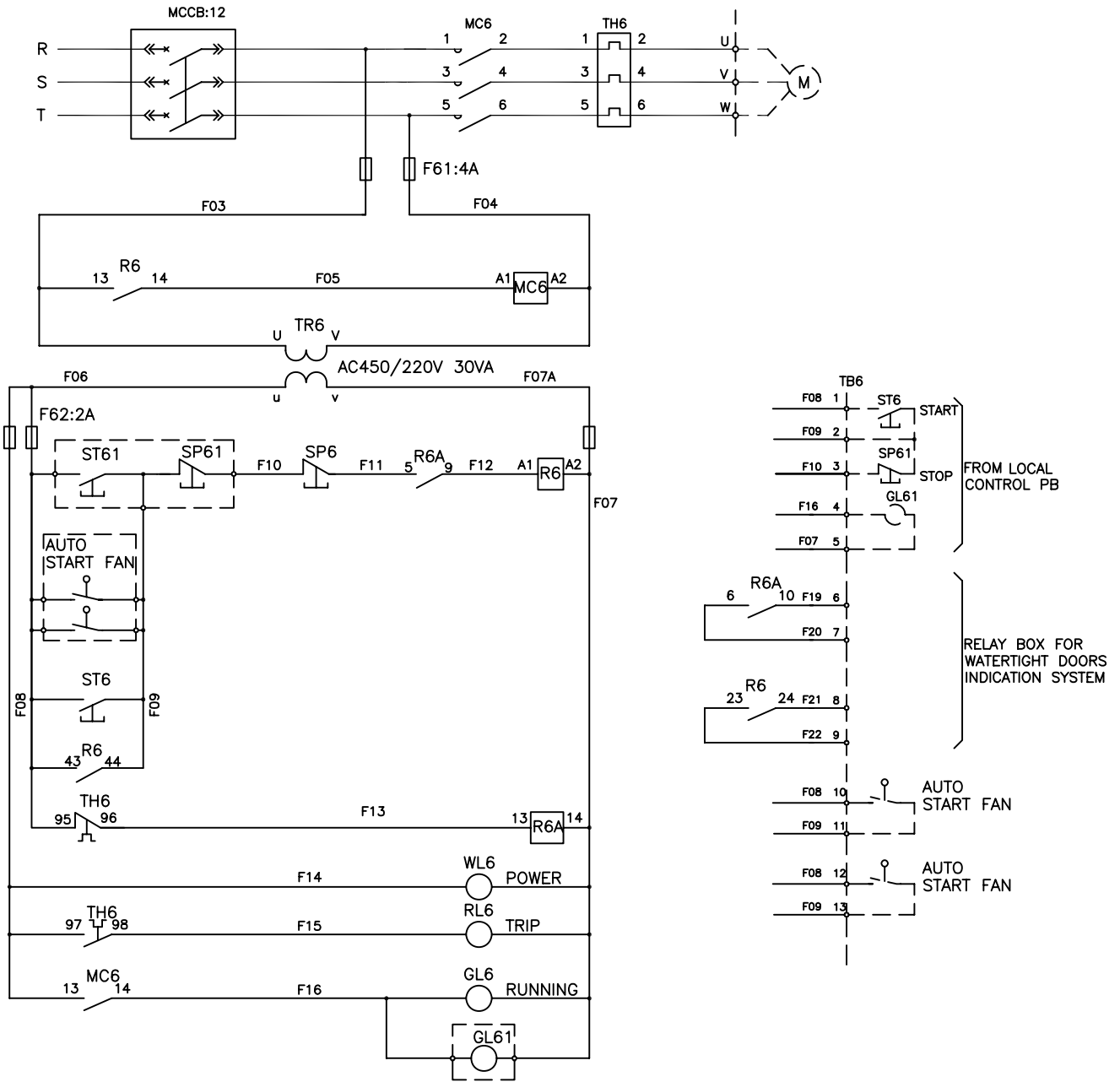

TB6 QT.13

NO.	1	2	3	4	5	6	7	8	9	10	11	12	13
	LOCAL CONTROL PUSHBUTTON BOX					ABNORMAL ALARM TO RELAY BOX	RUNNING TO RELAY BOX	AUTO START FAN	AUTO START FAN				
CABLE	411P12-5					411P12-3	411P12-3	411P12-1	411P12-2				

AIR LOCK SUPPLY FAN

SCHEMATIC DIAGRAM

411ST6(12)
2-61

A B C D E F G H I



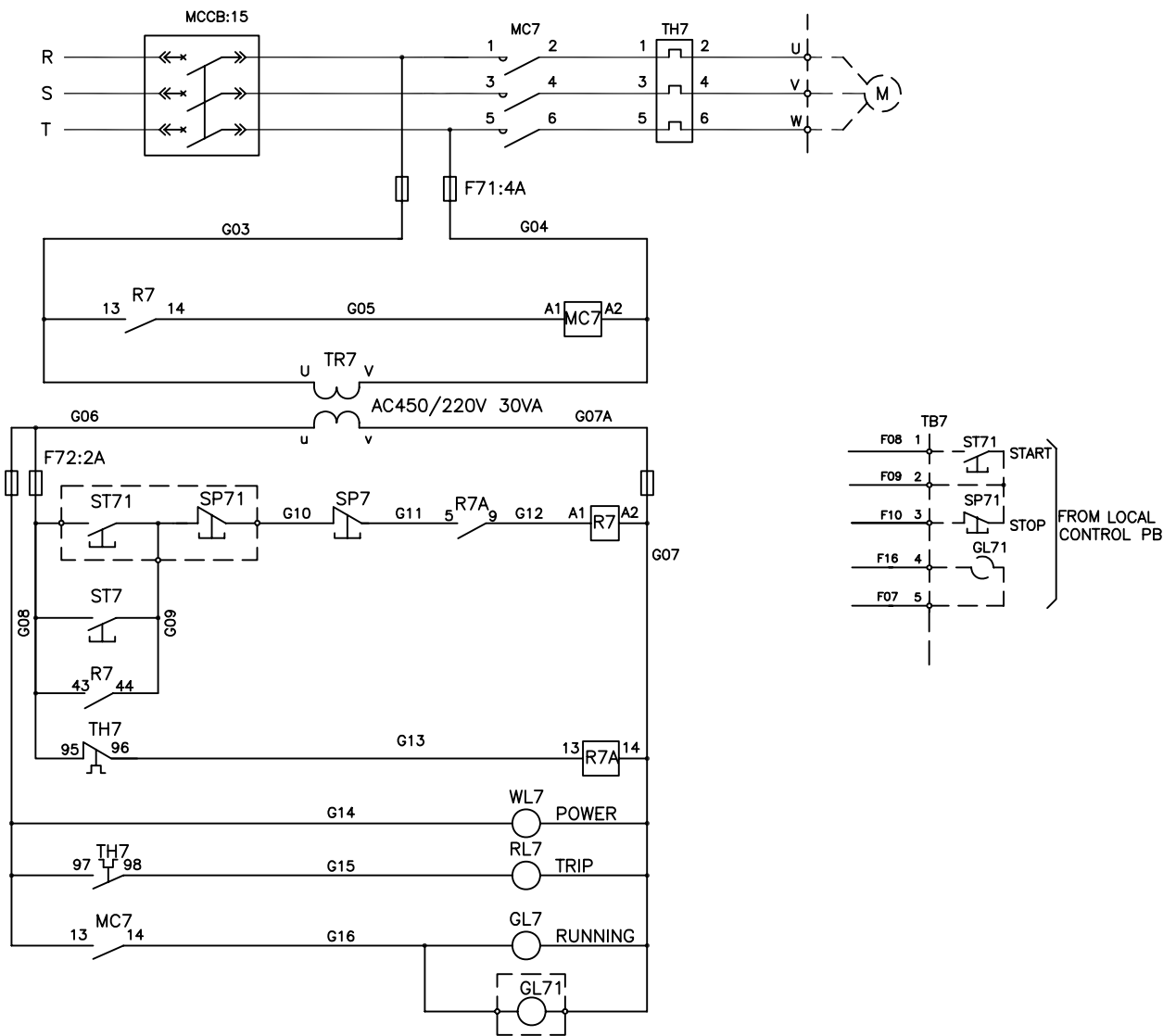

TB7		QT.5				
NO.	1	2	3	4	5	
	LOCAL CONTROL PUSHBUTTUON BOX					
CABLE	411P13-1					

FORECASTLE CO2 RM EXH.FAN

SCHMATIC DIAGRAM

411ST7(15)
2-62

A B C D E F G H I



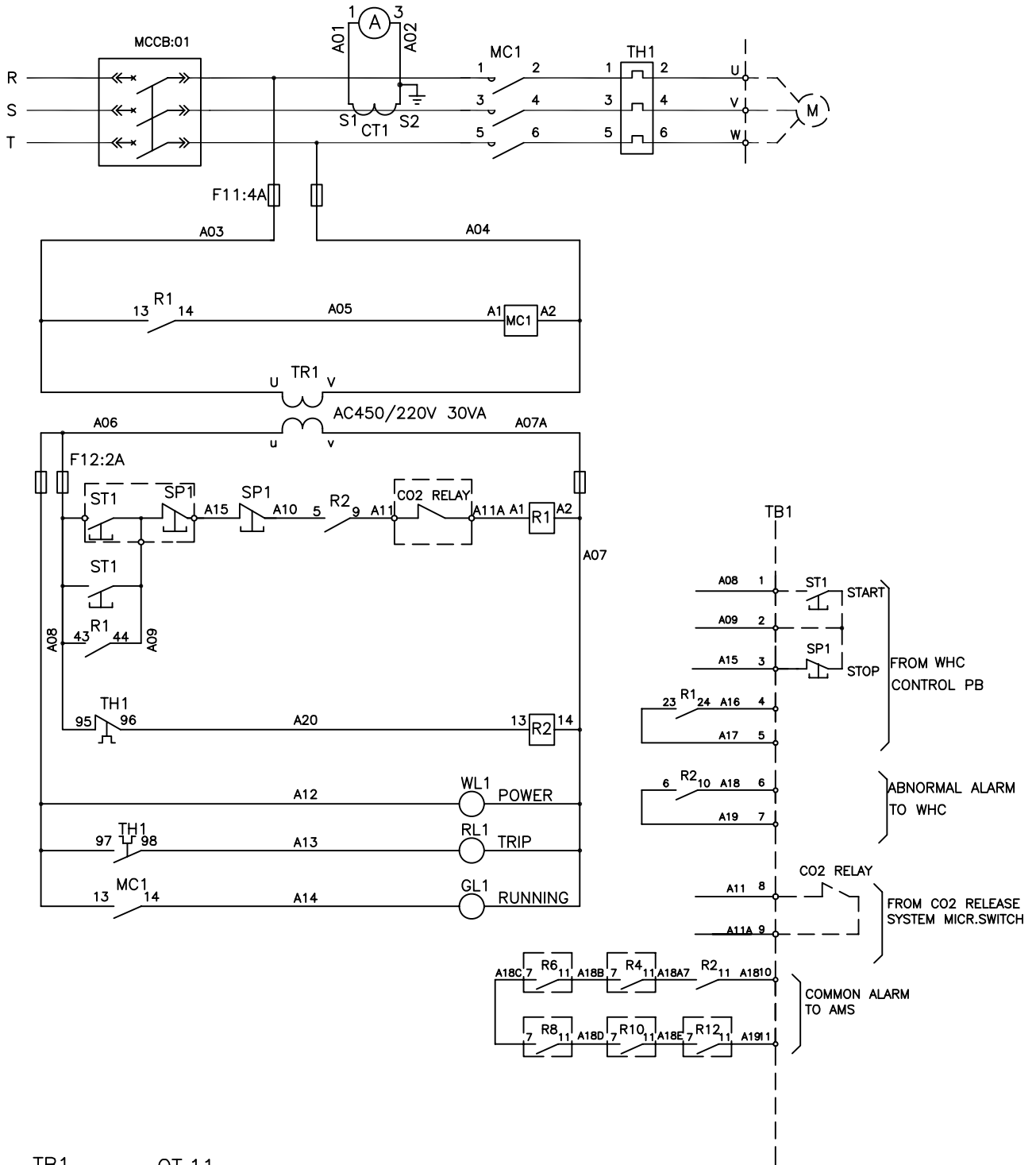

TB1 QT.11

TERMINAL No.	1	2	3	4	5	6	7	8	9	10	11
	FROM WHC CONTROL PB				ABNORMAL ALARM TO WHC		FROM CO2 RELEASE SYSTEM MICR.SWITCH		COMMON ALARM TO AMS		
CABLE No.	1CGH8				1CGH8		1CGH7		1CGH-A		

NO.1 CARGO HOLD EXH.FAN(P)

SCHMATIC DIAGRAM

3GSP1

2-63

A B C D A F G H I



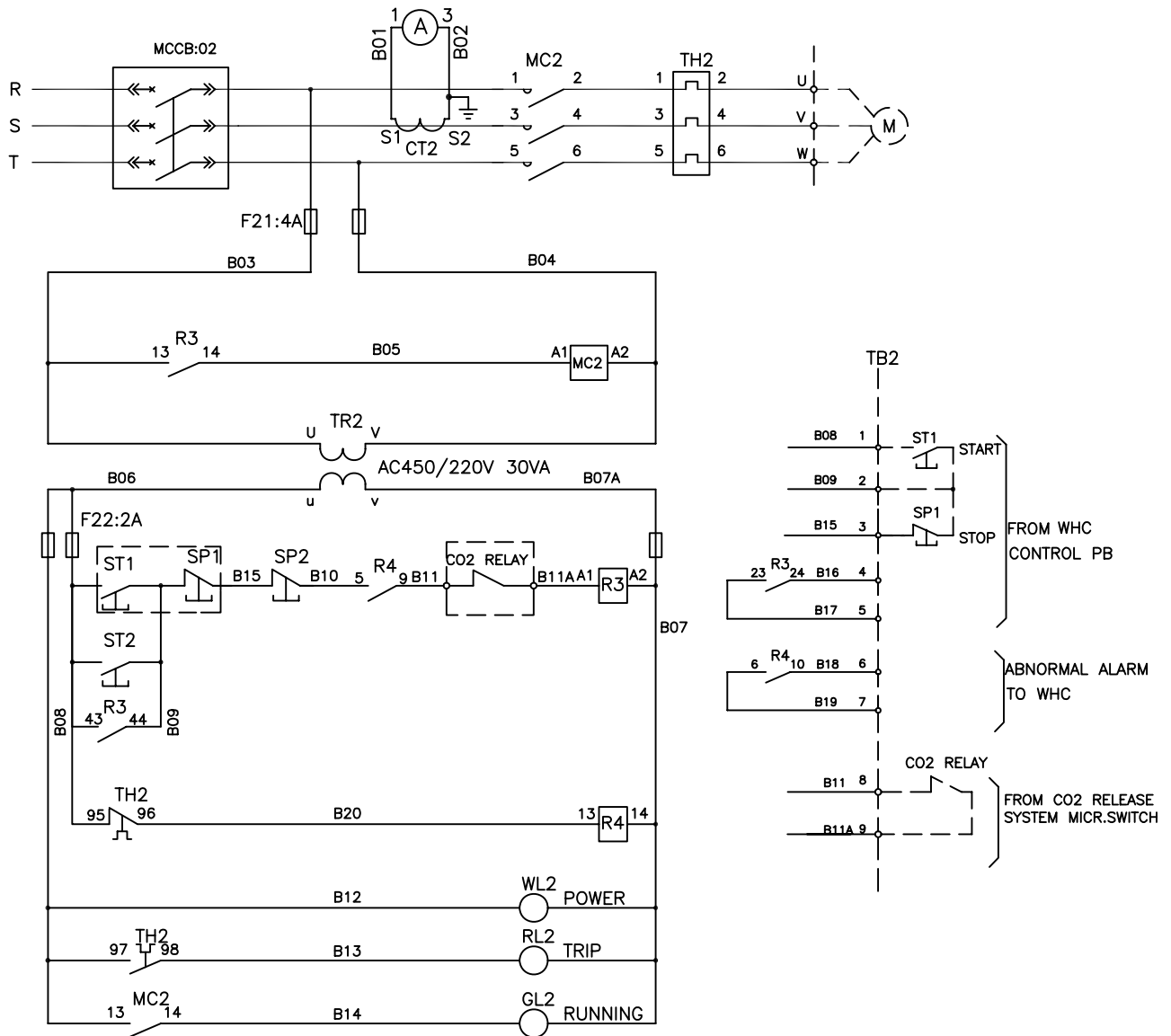

TB2 QT.9

TERMINAL No.	1	2	3	4	5	6	7	8	9
	FROM WHC CONTROL PB				ABNORMAL ALARM TO WHC		FROM CO2 RELEASE SYSTEM MICR.SWITCH		
CABLE No.	1CGH8				1CGH8		1CGH7		

NO.2 CARGO HOLD EXH.FAN(P)

SCHMATIC DIAGRAM

3GSP2

2-64

A B C D A F G H I



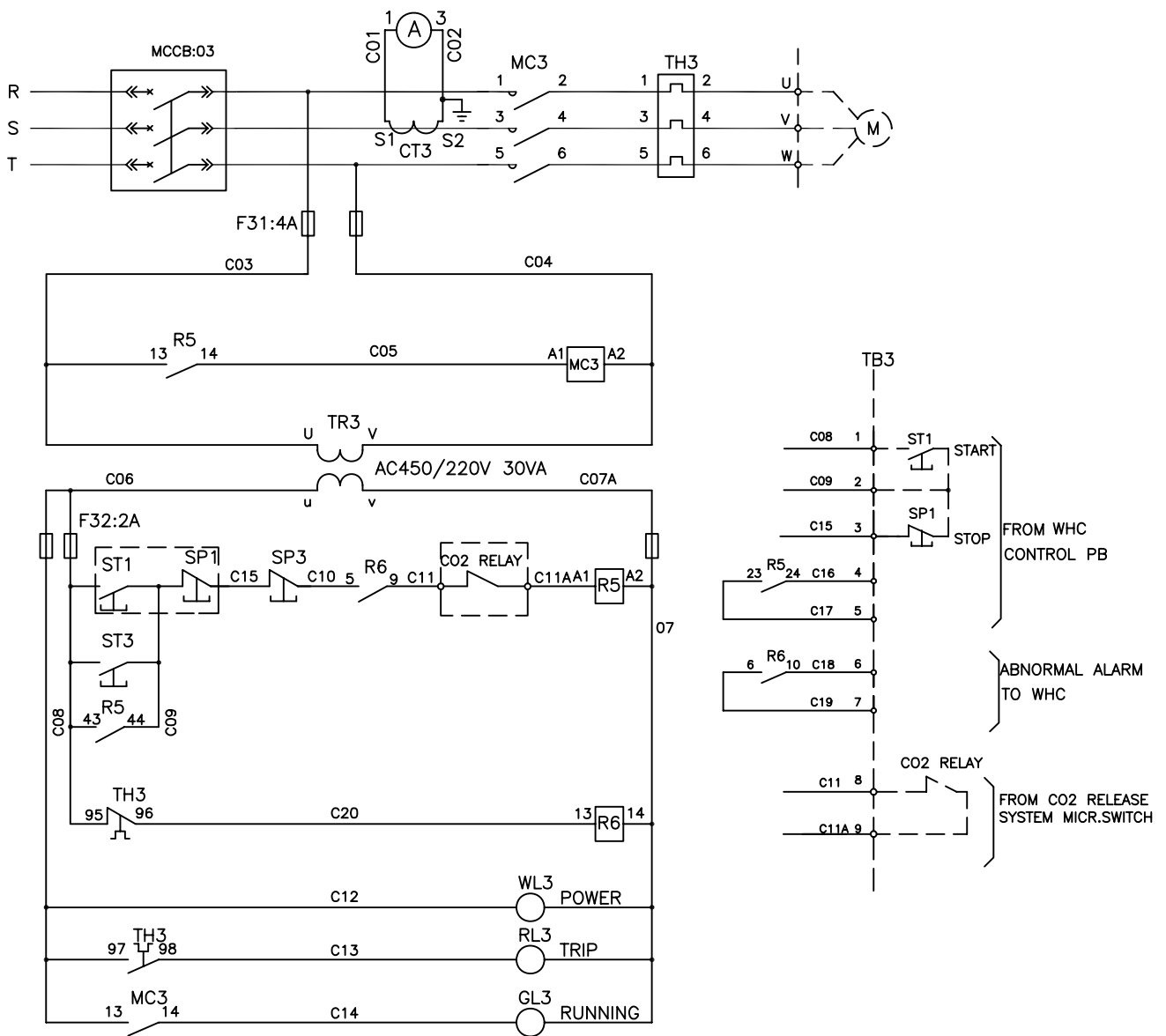

TB3 QT.9

TERMINAL No.	1	2	3	4	5	6	7	8	9
	FROM WHC CONTROL PB				ABNORMAL ALARM TO WHC		FROM CO2 RELEASE SYSTEM MICR.SWITCH		
CABLE No.	1CGH8				1CGH8		1CGH7		

NO.3 CARGO HOLD EXH.FAN(P)

A B C D A F G H I



SCHEMATIC DIAGRAM

3GSP3

2-65

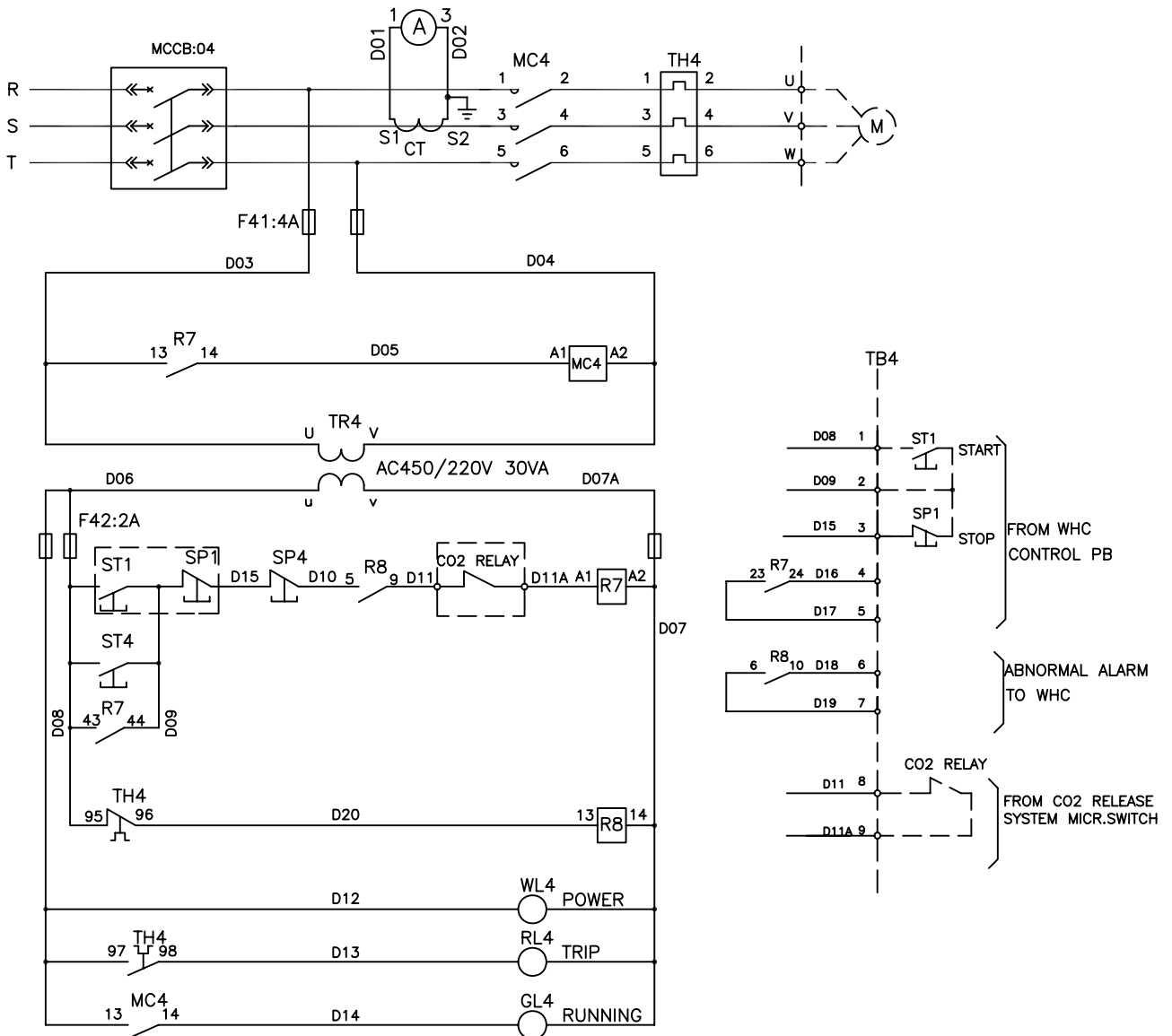

TB4 QT.9

TERMINAL No.	1	2	3	4	5	6	7	8	9
	FROM WHC CONTROL PB			ABNORMAL ALARM TO WHC		FROM CO2 RELEASE SYSTEM MICR.SWITCH			
CABLE No.	1CGH9			1CGH9		1CGH7			

NO.4 CARGO HOLD EXH.FAN(P)

SCHEMATIC DIAGRAM

3GSP4

2-66

A B C D A F G H I



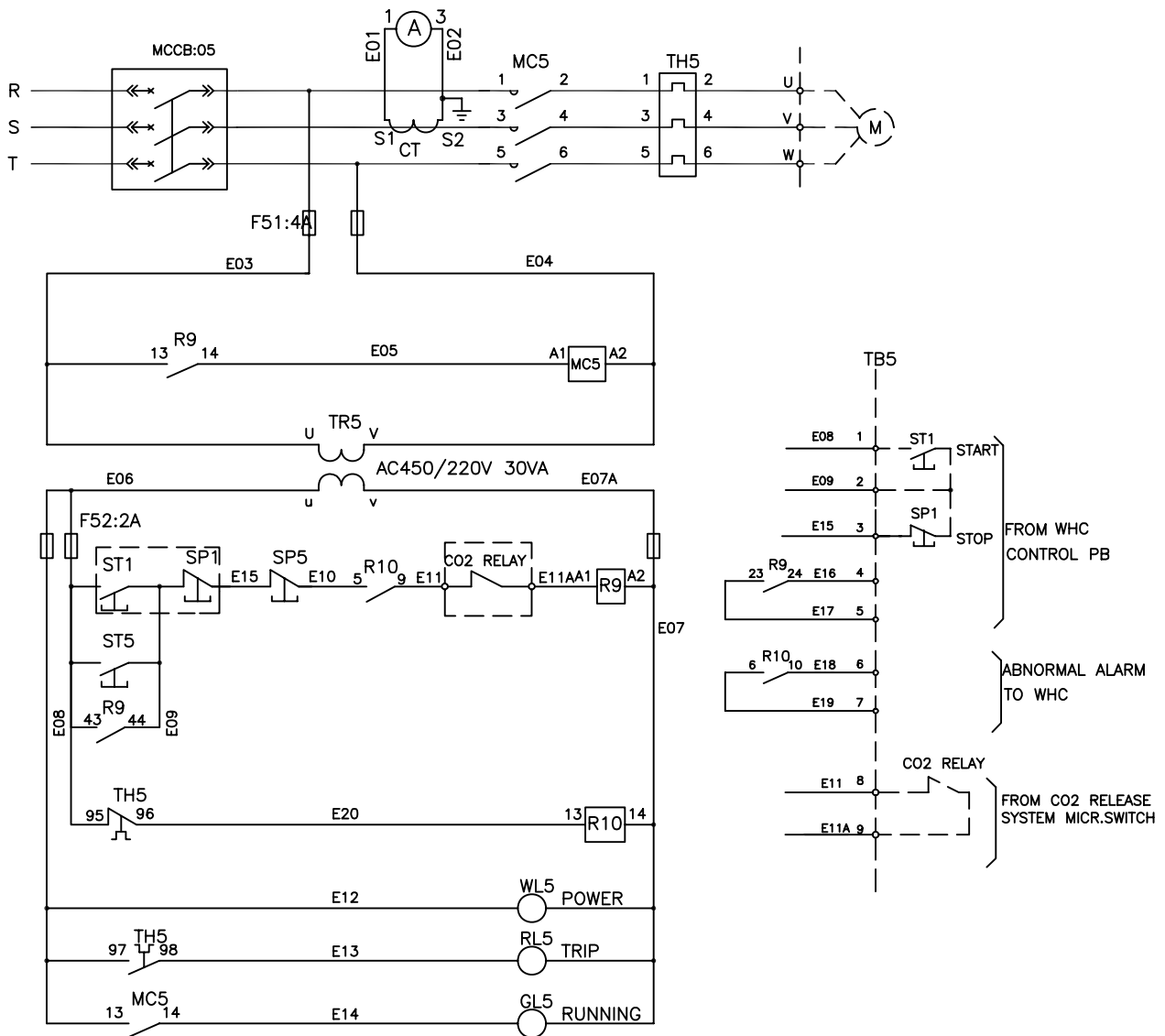

TB5 QT.9

TERMINAL No.	1	2	3	4	5	6	7	8	9
	FROM WHC CONTROL PB			ABNORMAL ALARM TO WHC		FROM CO2 RELEASE SYSTEM MICR.SWITCH			
CABLE No.	1CGH9			1CGH9		1CGH7			

NO.5 CARGO HOLD EXH.FAN(P)

SCHEMATIC DIAGRAM

3GSP5

2-67

A B C D A F G H I



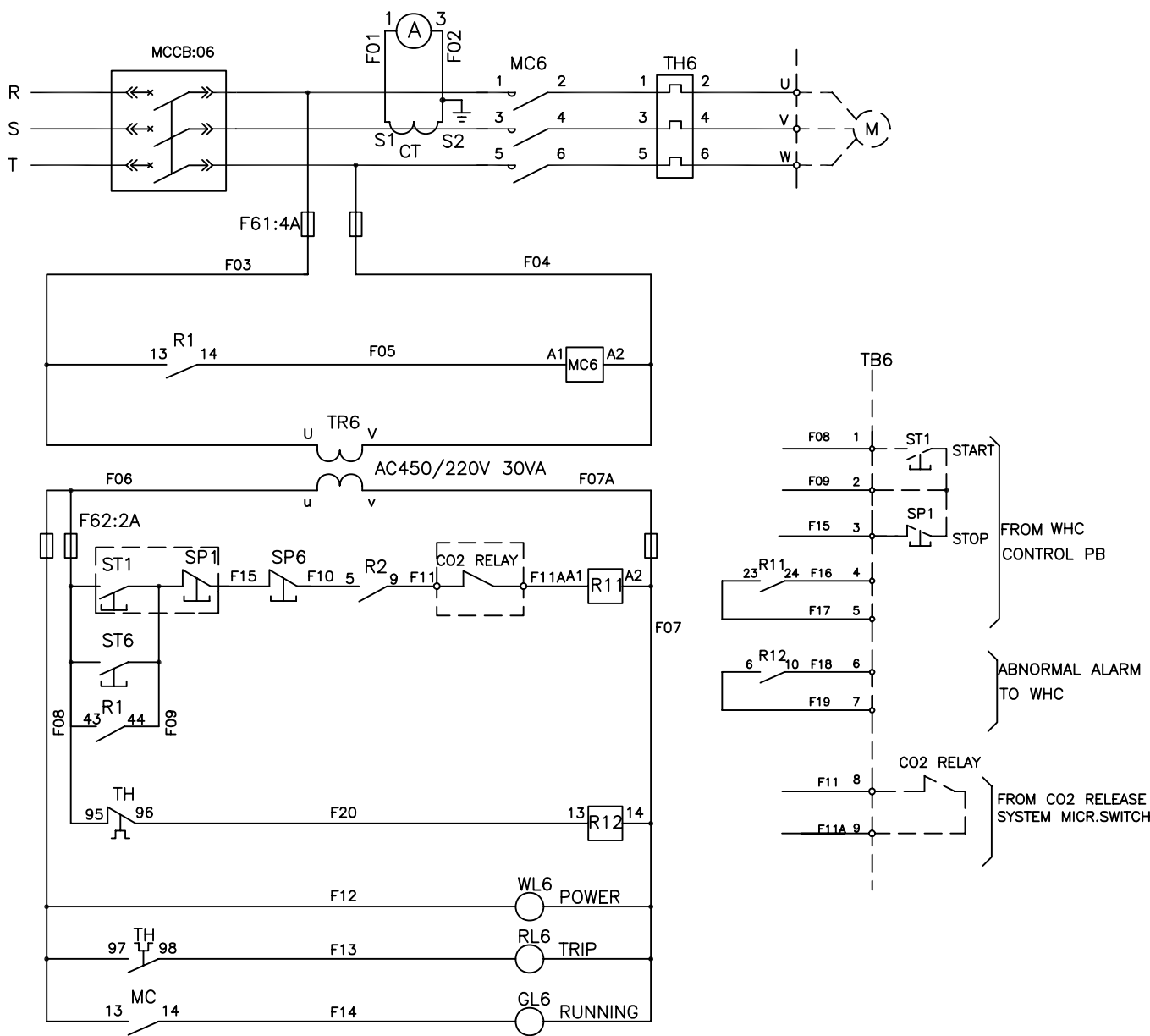

TB6 QT.9

TERMINAL No.	1	2	3	4	5	6	7	8	9
	FROM WHC CONTROL PB				ABNORMAL ALARM TO WHC		FROM CO2 RELEASE SYSTEM MICR.SWITCH		
CABLE No.	1CGH9				1CGH9		1CGH7		

NO.6 CARGO HOLD EXH.FAN(P)

SCHEMATIC DIAGRAM

3GSP6

2-68

A B C D E F G H I



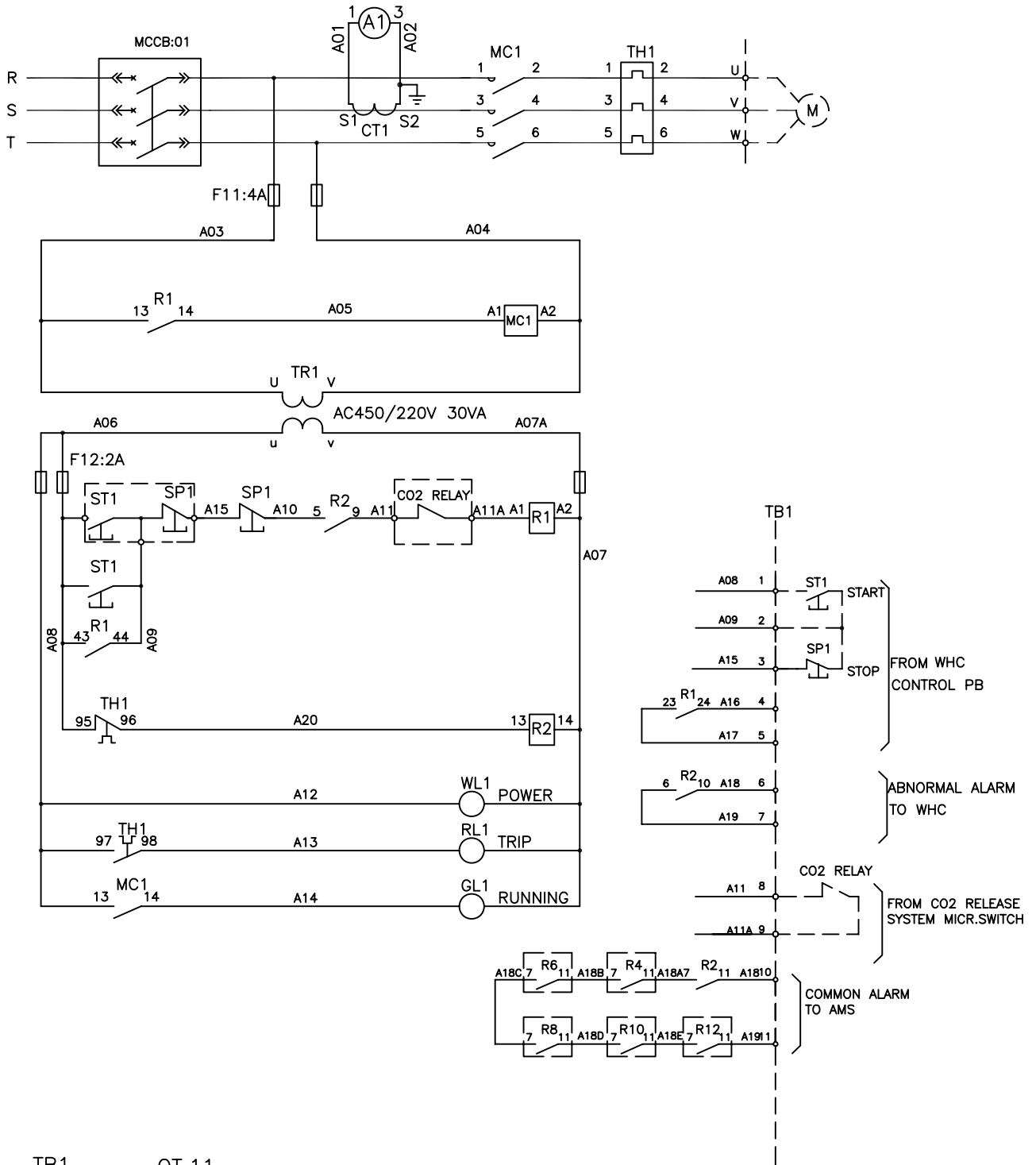

TB1 QT.11

TERMINAL No.	1	2	3	4	5	6	7	8	9	10	11
	FROM WHC CONTROL PB				ABNORMAL ALARM TO WHC		FROM CO2 RELEASE SYSTEM MICR.SWITCH		COMMON ALARM TO AMS		
CABLE No.	2CGH8				2CGH8		2CGH7		2CGH-A		

NO.1 CARGO HOLD EXH.FAN(S)

SCHMATIC DIAGRAM

4GSP1

2-69

A B C D A F G H I



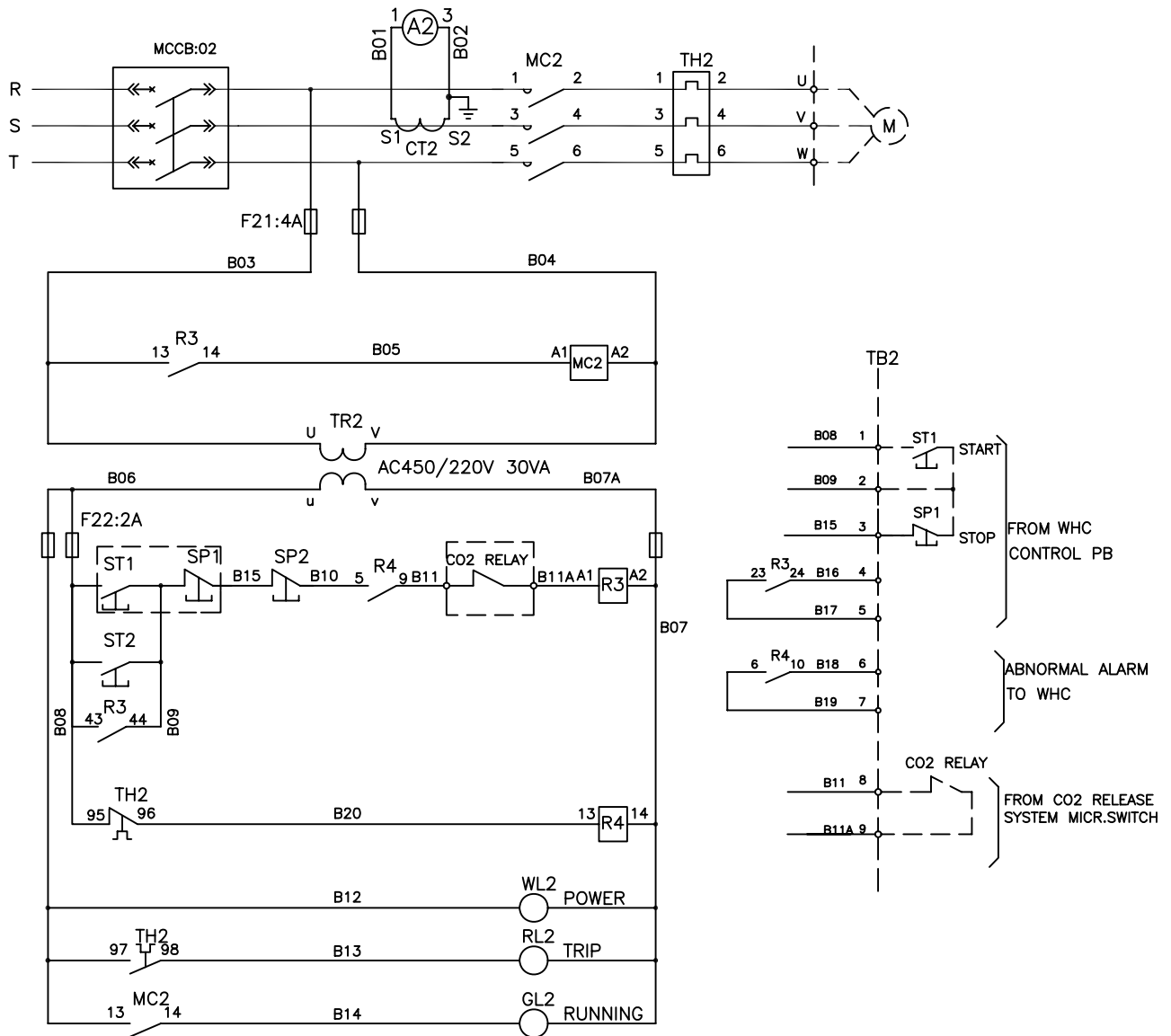

TB2 QT.9

TERMINAL No.	1	2	3	4	5	6	7	8	9
	FROM WHC CONTROL PB				ABNORMAL ALARM TO WHC		FROM CO2 RELEASE SYSTEM MICR.SWITCH		
CABLE No.	2CGH8				2CGH8		2CGH7		

NO.2 CARGO HOLD EXH.FAN(S)

A B C D A F G H I



SCHEMATIC DIAGRAM

4GSP2
2-70

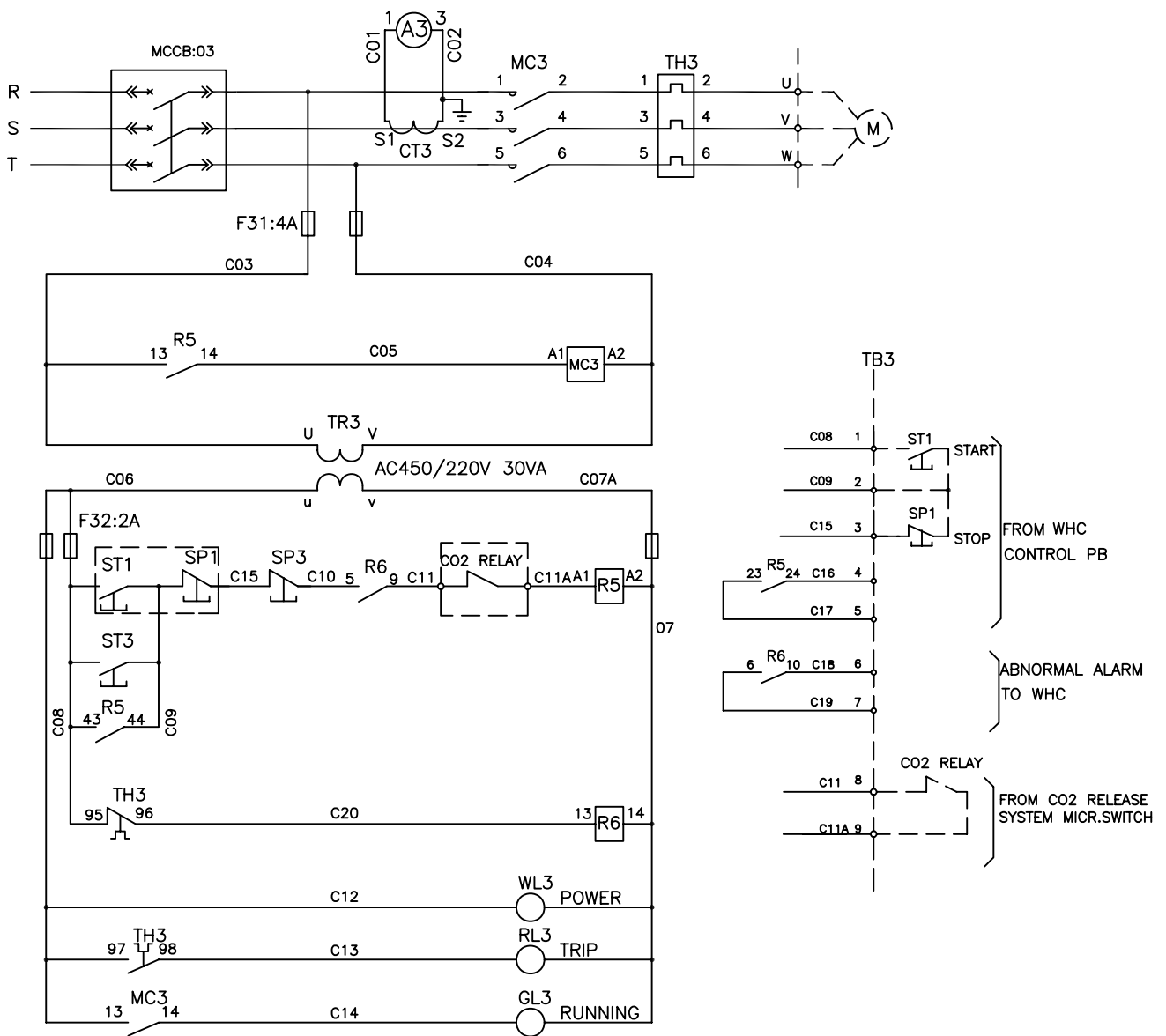

TB3 QT.9

TERMINAL No.	1	2	3	4	5	6	7	8	9
	FROM WHC CONTROL PB				ABNORMAL ALARM TO WHC		FROM CO2 RELEASE SYSTEM MICR.SWITCH		
CABLE No.	2CGH8				2CGH8		2CGH7		

NO.3 CARGO HOLD EXH.FAN(S)

SCHEMATIC DIAGRAM

4GSP3

2-71

A B C D A F G H I



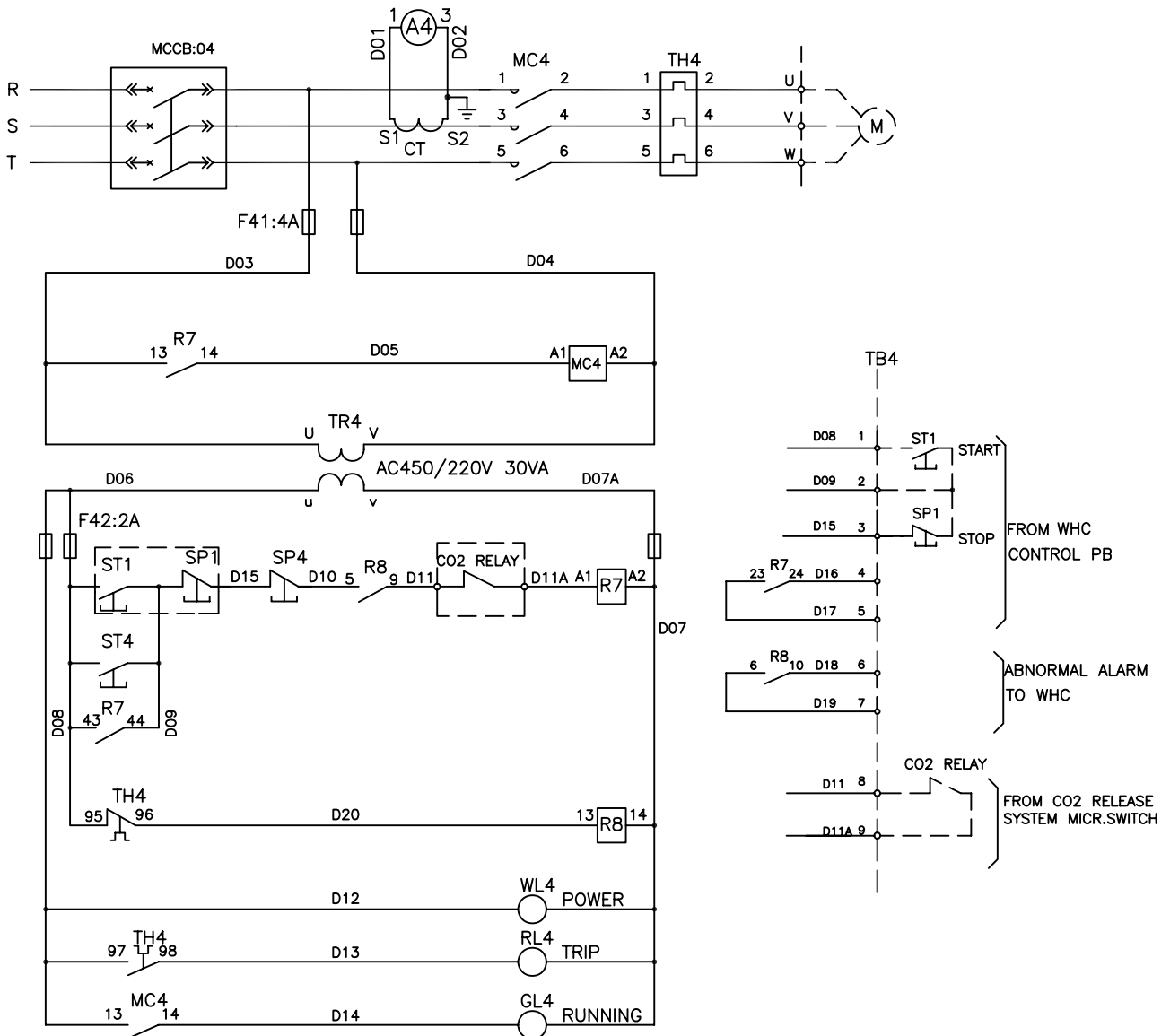

TB4 QT.9

TERMINAL No.	1	2	3	4	5	6	7	8	9
	FROM WHC CONTROL PB				ABNORMAL ALARM TO WHC		FROM CO2 RELEASE SYSTEM MICR.SWITCH		
CABLE No.	2CGH9				2CGH9		2CGH7		

NO.4 CARGO HOLD EXH.FAN(S)

SCHEMATIC DIAGRAM

4GSP4

2-72

A B C D A F G H I



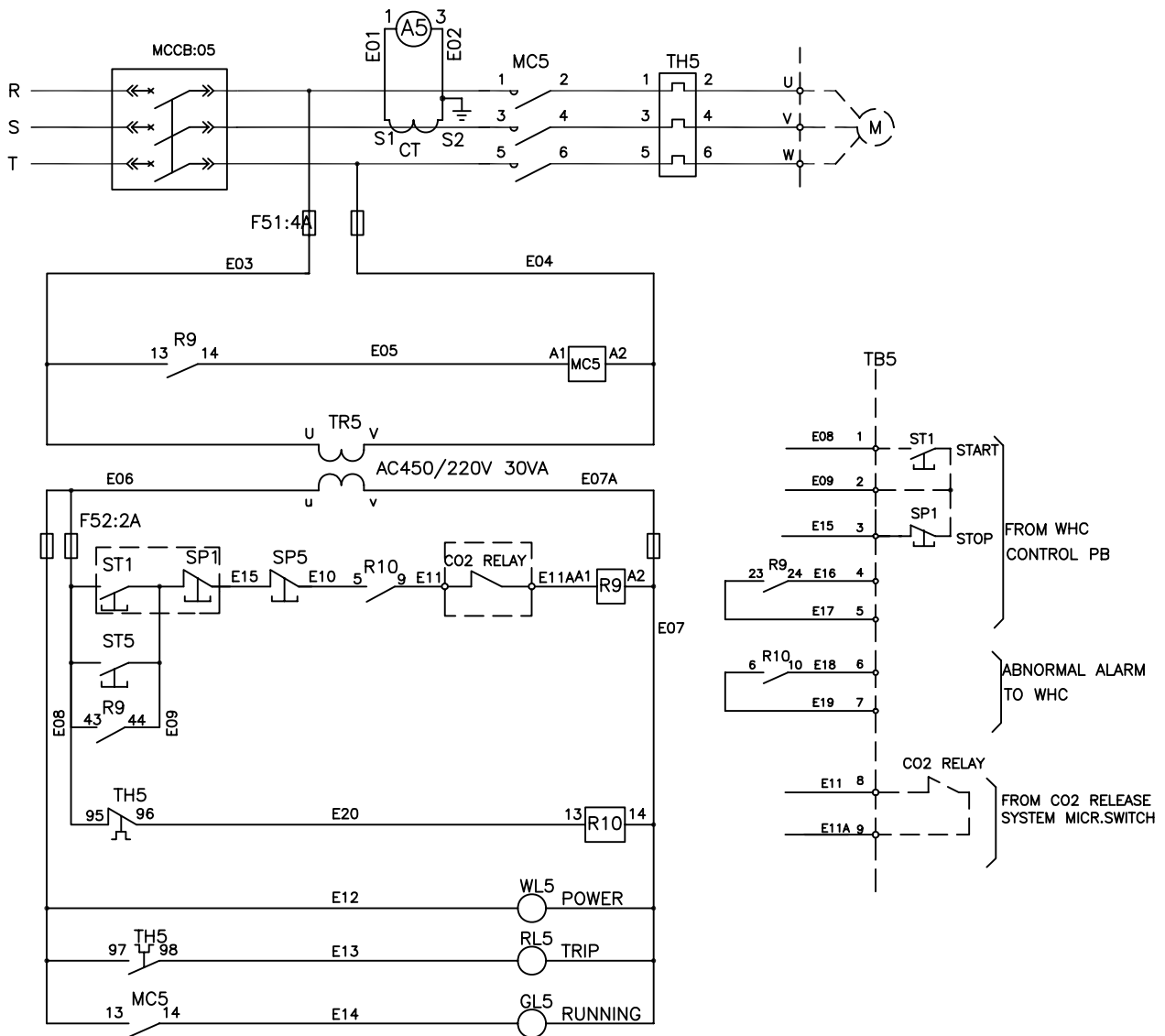

TB5 QT.9

TERMINAL No.	1	2	3	4	5	6	7	8	9
	FROM WHC CONTROL PB			ABNORMAL ALARM TO WHC		FROM CO2 RELEASE SYSTEM MICR.SWITCH			
CABLE No.	2CGH9			2CGH9		2CGH7			

NO.5 CARGO HOLD EXH.FAN(S)

SCHEMATIC DIAGRAM

4GSP5

2-73

A B C D A F G H I



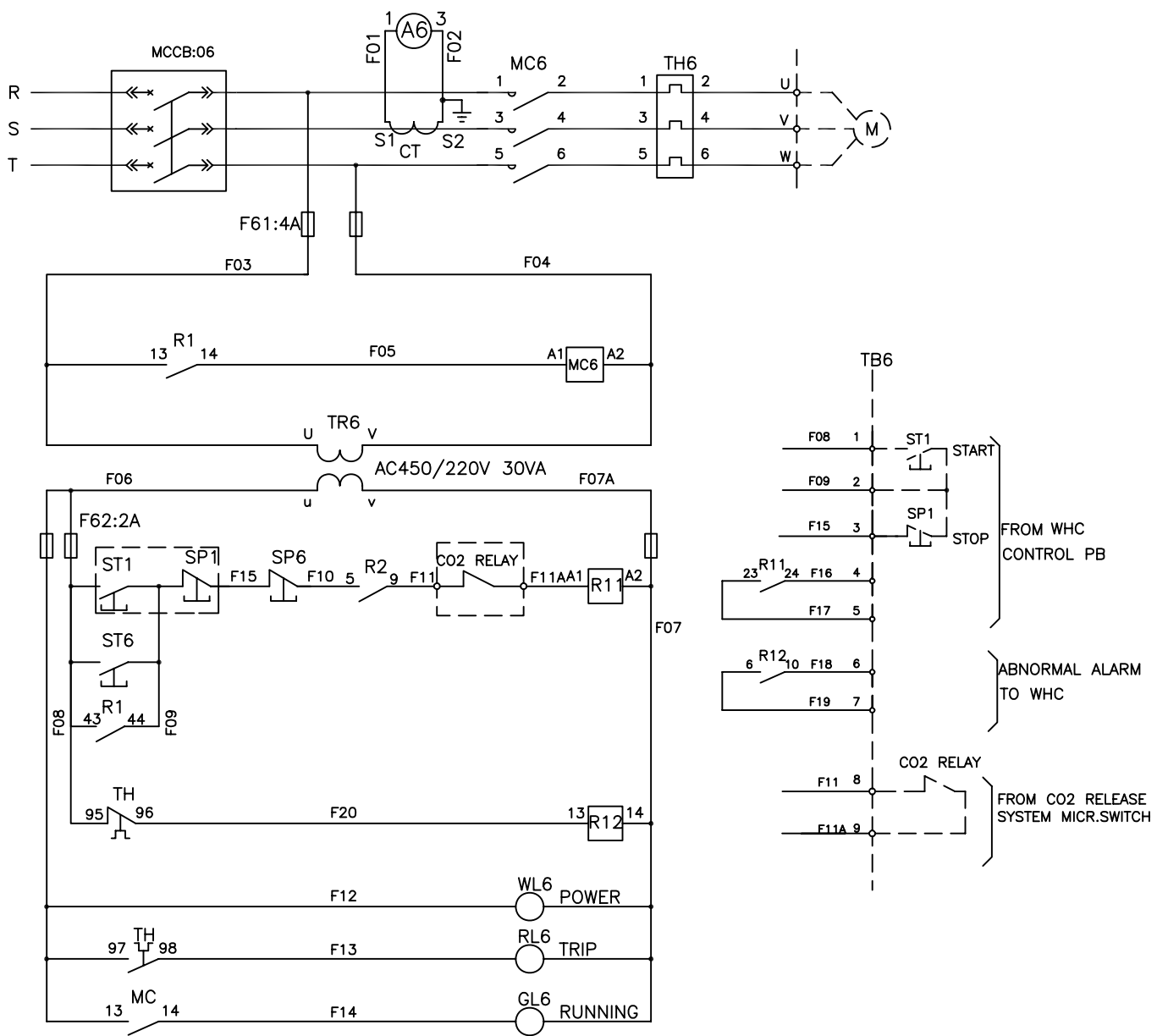

TB6 QT.9

TERMINAL No.	1	2	3	4	5	6	7	8	9
	FROM WHC CONTROL PB			ABNORMAL ALARM TO WHC		FROM CO2 RELEASE SYSTEM MICR.SWITCH			
CABLE No.	2CGH9			2CGH9		2CGH7			

NO.6 CARGO HOLD EXH.FAN(S)

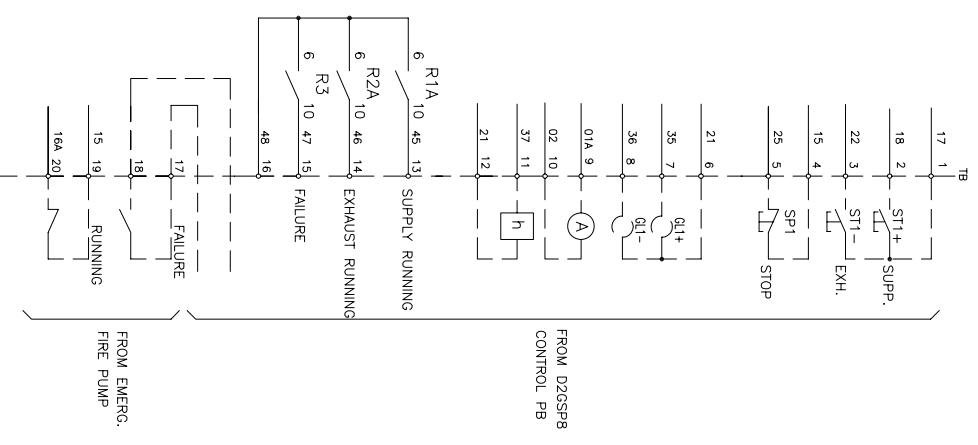
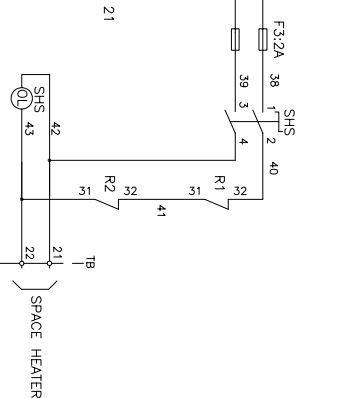
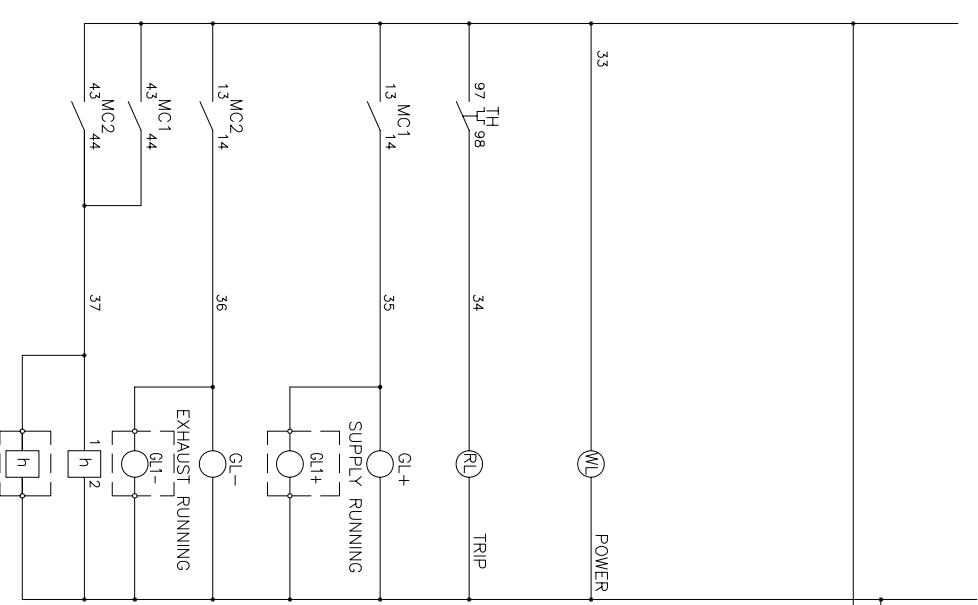
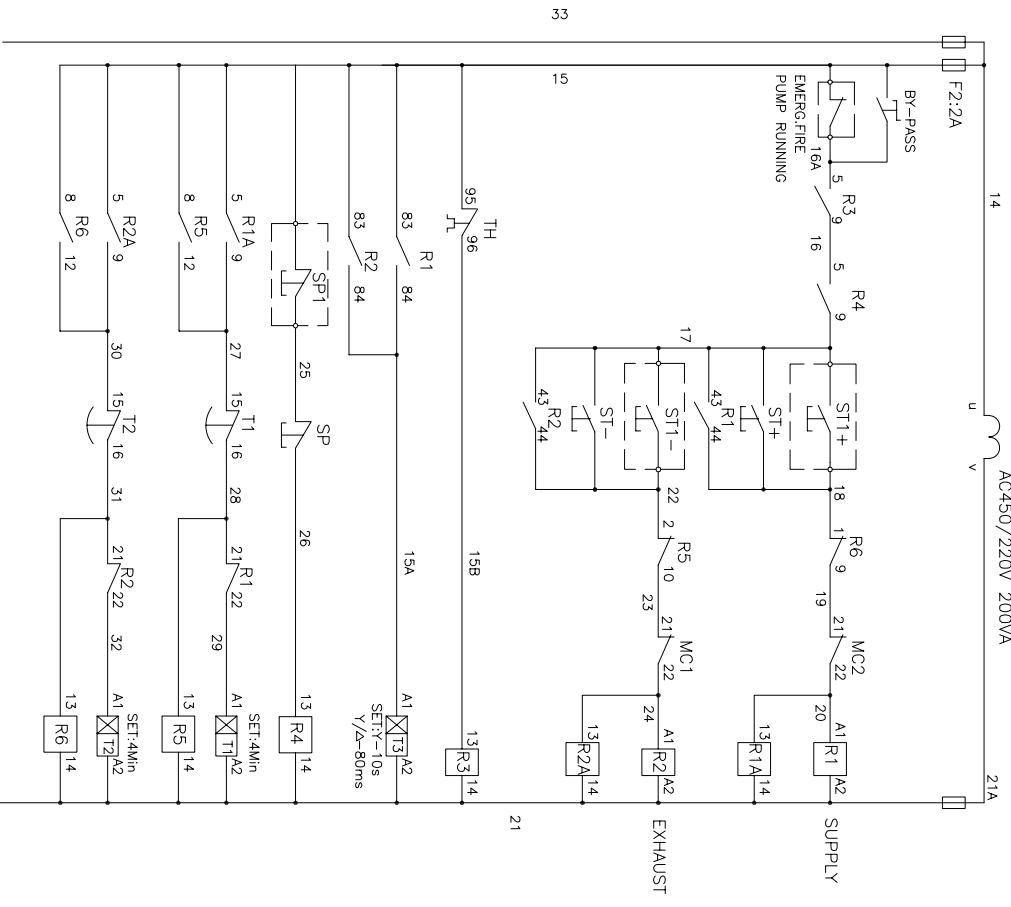
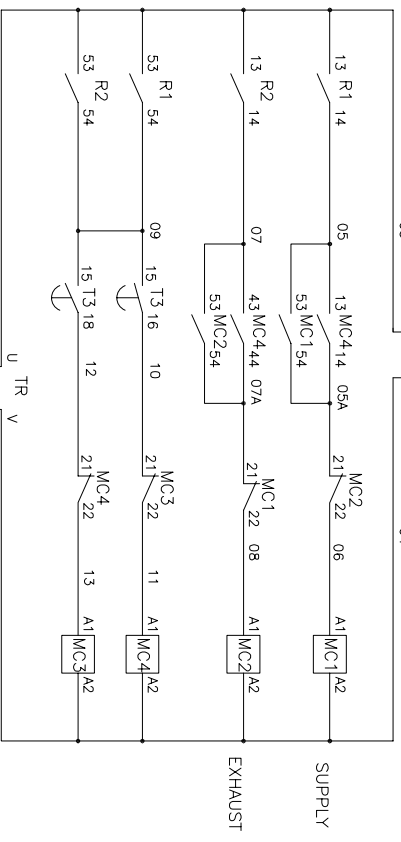
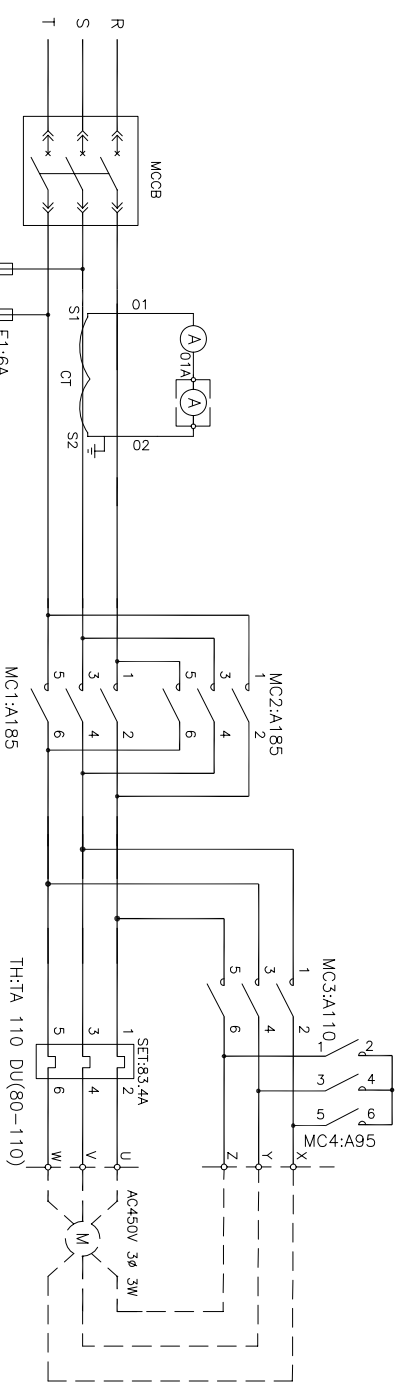

TERMINAL NO.	1	2	3	4	5	6	7	8	9	10	11	12	13	14	15	16	17	18	19	20	21	22
CABLE No.	4ERF-4																				4ERF-3	
	FROM MSB CONTROL PB																				FAILURE&RUNNING SIGNAL FROM EMERG. FIRE PUMP	
	4ERF-4																				EFP8	

A B C D E F G H I



SCHEMATIC DIAGRAM

ST1
2-75

No.4 E/R VENT FAN(SUPPLY & EXHAUST)

VOL.3

CABLE ENTRANCE SPACE CE

TERMINAL ARRANGEMENT AND BLOCK T

REAR INCOMING
(W=350)

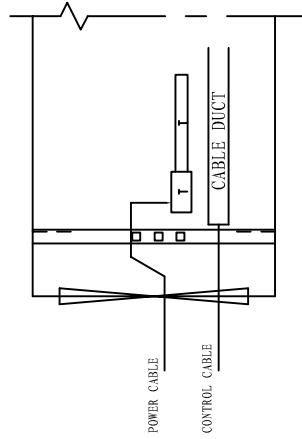

REAR VIEW

REAR

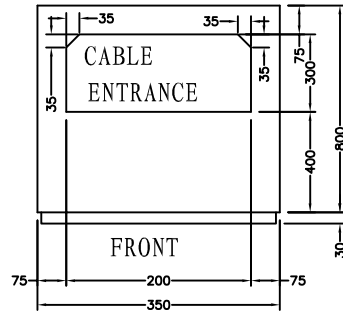

BOTTOM VIEW

NAME	PANEL NO.
No.1 GSP	A,B,C,D,E
No.2 GSP	G,H,I,J,K

REAR INCOMING
(W=700)

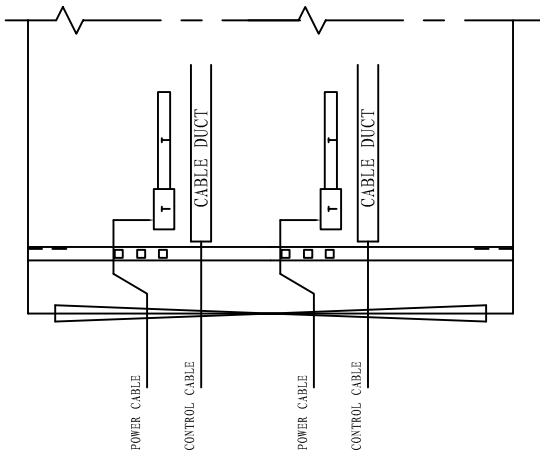

REAR VIEW

REAR

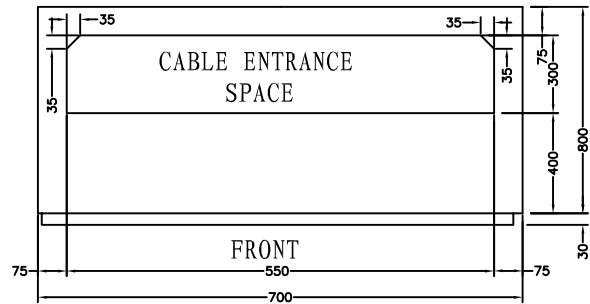

BOTTOM VIEW

NAME	PANEL NO.
No.1 GSP	F
No.1 GSP	L

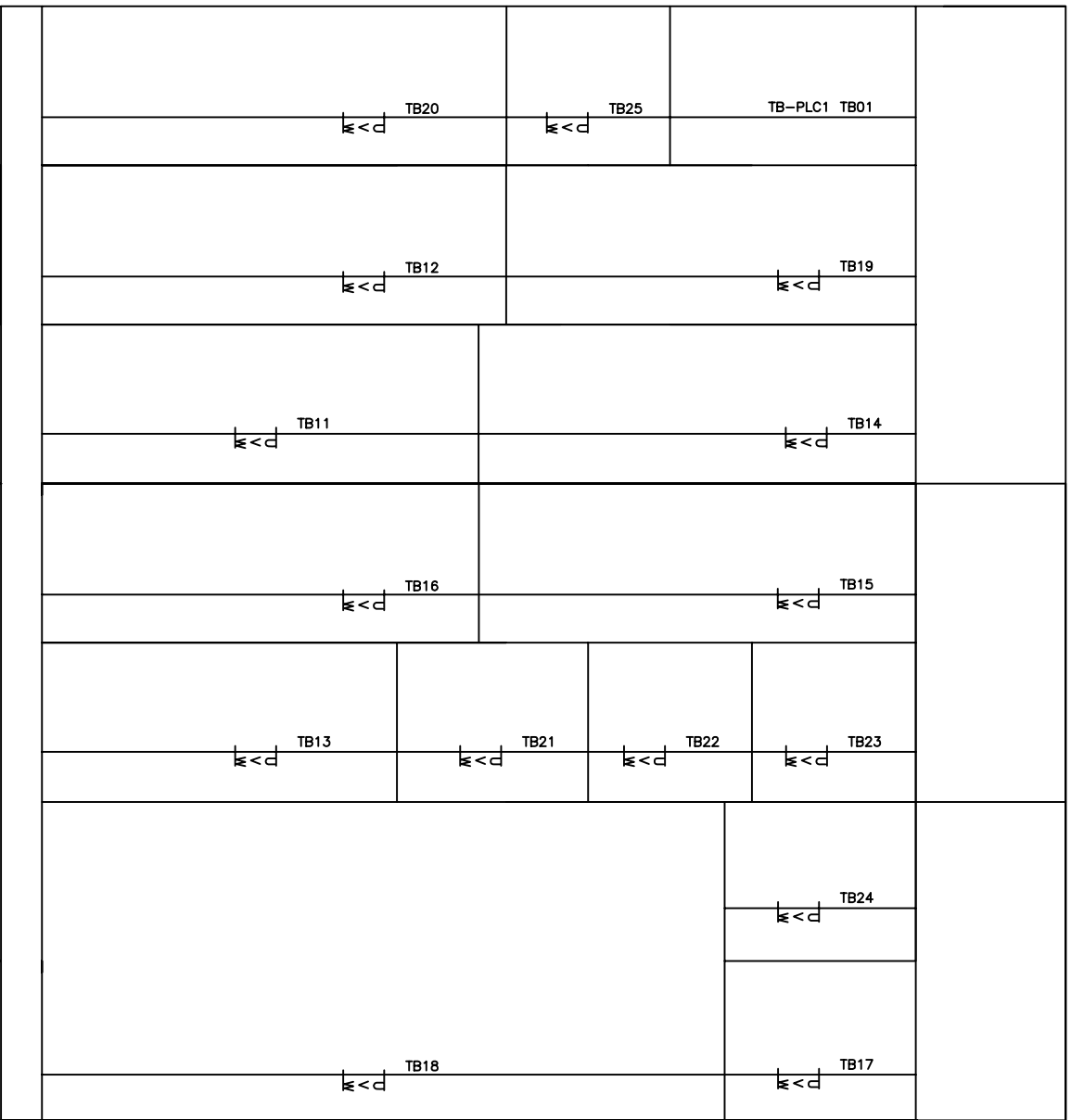

NO.1 GSP

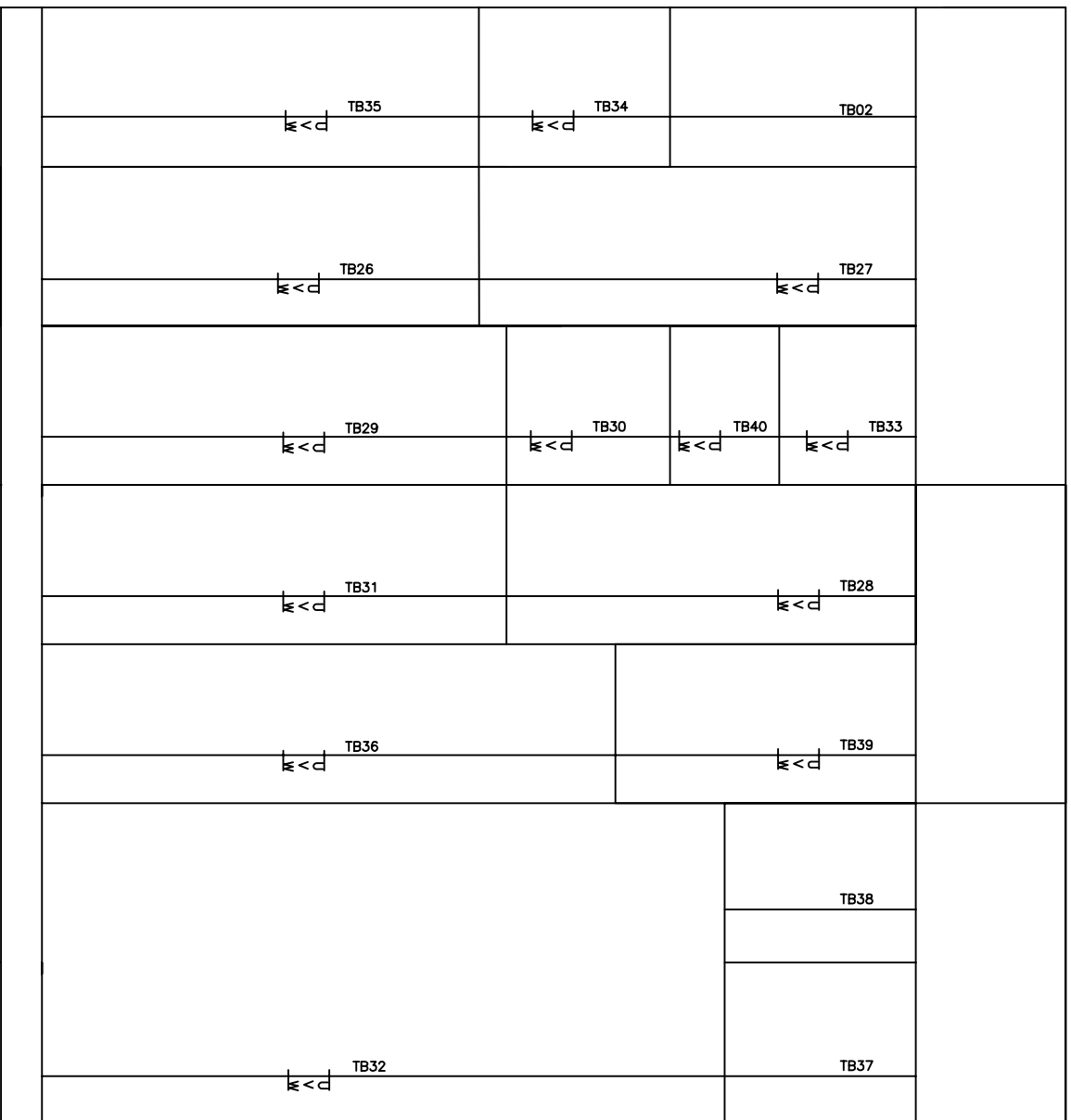

NO.2 GSP

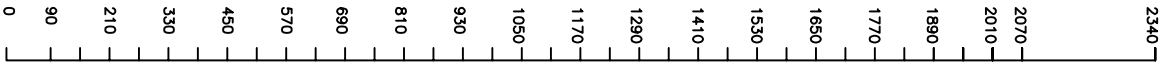

A B C D E F G H I



GROUP STARTER PANEL TEMERAL
COLLOCATION(REAR VIEW)

TB01

NO.	1	2	3	4	5	6	7	8	9	10	11	12	13	14
	PS		PS		PS		PS		PS		PS		ESS	
CABLE	1LTW-4		1MJW-4		1CSW-4		3CSW-4		1MLO-5		1STOP2		1CSW-ES	

TB11

NO.	1	2
	TO SPACE HEATER	
CABLE	1ERF-2	

TB12

NO.	1	2	3	4	5	6	7
	LOCAL CONTROL PB					TO SPACE HEATER	
CABLE	1LTW-3					1LTW-2	

TB13

NO.	1	2	3	4	5	6	7
	LOCAL CONTROL PB					TO SPACE HEATER	
CABLE	1MJW-3					1MJW-2	

TB14

NO.	1	2	3	4	5	6	7
	LOCAL CONTROL PB					TO SPACE HEATER	
CABLE	1CSW-3					1CSW-2	

TB15

NO.	1	2
	TO SPACE HEATER	
CABLE	3ERF-2	

TB16

NO.	1	2	3	4	5	6	7
	LOCAL CONTROL PB					TO SPACE HEATER	
CABLE	3CSW-3					3CSW-2	

TB17

NO.	1	2	3	4	5	6	7	8	9	10	11	12	13	14	15	16	17	18	19	20	21	22
	LOCAL CONTROL PB				FROM VALVE CABINET CONTROL PB						EMERG. STOP BUTTON		LOW LEVEL		HIGH LEVEL		LOW LEVEL		HIGH LEVEL		FROM VALVE CABINET CONTROL PB	
CABLE	HFOT-2				HFOT-8						HFOT-7		HFOT-4		HFOT-3		HFOT-6		HFOT-5		HFOT-8	

TB18

NO.	1	2	3	4	5	6	7
	LOCAL CONTROL PB					TO SPACE HEATER	
CABLE	1MLO-4					1MLO-3	

TB19

NO.	1	2	3	4	5	6	7	8	9	10	11	12	13	14	15	16
	LOCAL CONTROL PB					FROM VALVE CABINET CONTROL PB					SELF-PRIMING UNIT		SPACE HEATER		FROM VALVE CABINET CONTROL PB	
CABLE	1BP4					1BP5					1BP3		1BP2		1BP5	

TB20

NO.	1	2	3	4	5	6	7	8	9	10	11	12	13	14	15	16	17	18	19	20	21	22	23	24	25	26	27	28
	LOCAL CONTROL PB				FROM FIRE STATION CONTROL PB						FROM WHC CONTROL PB				FROM VALVE CABINET CONTROL PB				SELF-PRIMING UNIT		SPACE HEATER		FROM VALVE CABINET CONTROL PB					
CABLE	1FGBP4				1FGBP6						1FGBP7				1FGBP5				1FGBP3		1FGBP2		1FGBP5					

TB21

NO.	1	2	3	4	5	6	7	8	9
	LOCAL CONTROL PB					LOW LEVEL		HIGH LEVEL	
CABLE	1COTP2					1COTP4		1COTP3	

TB22

NO.	1	2	3	4	5	6	7
	LOCAL CONTROL PB					EMERGENCY STOP	
CABLE	DBP2					DBP3	

TB23

NO.	1	2	3	4	5	6	7
	LOCAL CONTROL PB					SPACE HEATER	
CABLE	1STOP3					1STOP2	

TB24

NO.	1	2	3	4	5
	LOCAL CONTROL PB				
CABLE	LOTP2				

TB25

NO.	1	2	3	4	5
	LOCAL CONTROL PB				
CABLE	ACCP2				

TB02

1	2	3	4	5	6
PS		PS		PS	
2CSW-4		2LTW-4		3LTW-4	

TB26

NO.	1	2
	TO SPACE HEATER	
CABLE	2ERF-2	

TB27

NO.	1	2	3	4	5	6	7
	LOCAL CONTROL PB					TO SPACE HEATER	
CABLE	2CSW-3					2CSW-2	

TB28

NO.	1	2	3	4	5	6	7
	LOCAL CONTROL PB					TO SPACE HEATER	
CABLE	2MJW-3					2MJW-2	

TB29

NO.	1	2	3	4	5	6	7
	LOCAL CONTROL PB					TO SPACE HEATER	
CABLE	2LTW-3					2LTW-2	

TB30

NO.	1	2	3	4	5
	LOCAL CONTROL PB				
CABLE	MJWH-2				

TB31

NO.	1	2	3	4	5	6	7
	LOCAL CONTROL PB					TO SPACE HEATER	
CABLE	3LTW-3					3LTW-2	

TB32

NO.	1	2	3	4	5	6	7
	LOCAL CONTROL PB					TO SPACE HEATER	
CABLE	2MLO-4					2MLO-3	

TB33

NO.	1	2	3	4	5	6	7	8	9	10	11	12	13	14	15	16
CABLE	4ERF-4															

TB34

NO.	1	2	3	4	5	6	7	8	9
	LOCAL CONTROL PB					EMERGENCY STOP		HIGH LEVEL	
CABLE	SOP2					SOP3		SOP4	

TB35

NO.	1	2	3	4	5	6	7	8	9	10	11	12	13	14	15	16
	LOCAL CONTROL PB					FROM VALVE CABINET CONTROL PB					SELF-PRIMING UNIT		SPACE HEATER		FROM VALVE CABINET CONTROL PB	
CABLE	2BP4					2BP5					2BP3		2BP2		2BP5	

TB36

NO.	1	2	3	4	5	6	7	8	9	10	11	12	13	14	15	16	17	18	19	20	21	22	23	24	25	26	27	28
	LOCAL CONTROL PB					FROM FIRE STATION CONTROL PB					FROM WHC CONTROL PB					FROM VALVE CABINET CONTROL PB					SELF-PRIMING UNIT		SPACE HEATER		FROM VALVE CABINET CONTROL PB			
CABLE	2FCBP4					2FCBP6					2FCBP7					2FCBP5					2FCBP3		2FCBP2		2FCBP5			

TB37

NO.	1	2	3	4	5
	LOCAL CONTROL PB				
CABLE					

NO.	1	2	3	4	5	6	7
	LOCAL CONTROL PB					SPACE HEATER	
CABLE	2STOP2					2STOP2	

TB38

TB39

NO.	1	2	3	4	5	6	7	8	9	10	11	12	13	14
	LOCAL CONTROL PB					FROM VALVE CABINET CONTROL PB					EMERGENCY STOP		FROM VALVE CABINET CONTROL PB	
CABLE	DOTP2					DOTP4					DOTP3		DOTP4	

TB40

NO.	1	2	3	4	5	6
	MSB CONTROL PB TO STEERING GEAR ROOM SUPPLY FAN					
CABLE	409P9-3					