

Indian Maritime University
(A Central University, Govt of India)

Sep/Oct'25 SE

Programme Name: B Tech (Marine Engineering)

Semester: II

Subject Code: UG11T4204

Subject Name: ENGINEERING MECHANICS

Date: 12-09-2025

Max Marks: 70

Duration: 03 Hrs

Pass Marks: 35

General Instructions

- (i) All Sections (A, B & C) are to be attempted.
- (ii) Options, if any, are specified in respective section.

Section A

Ten MCQs/Fill in the Blanks of 01 Mark each – Choose the correct answer as applicable.

1. In ideal machines, mechanical advantage is _____ velocity ratio
 - (a) equal to
 - (b) less than
 - (c) greater than
 - (d) No Relation
2. The periodic time of one oscillation for a simple pendulum is (where l = Length of the pendulum.)
 - (a) $\frac{1}{2\pi} \sqrt{\frac{l}{g}}$
 - (b) $\frac{1}{2\pi} \sqrt{\frac{g}{l}}$
 - (c) $2\pi \sqrt{\frac{l}{g}}$
 - (d) $2\pi \sqrt{\frac{g}{l}}$
3. The torque acting on a body of moment of inertia (I) and angular acceleration (α) is

- (a) $I\alpha$
 - (b) $I\alpha^2$
 - (c) $0.5 I\alpha$
 - (d) $0.5 I\alpha^2$
4. The point, through which the whole weight of the body acts, irrespective of its position, is known as
- (a) moment of inertia
 - (b) centre of gravity
 - (c) centre of percussion
 - (d) centre of mass
5. Which axial force is determined while analyzing a truss?
- (a) compressive force
 - (b) tensile force
 - (c) both (a) and (b)
 - (d) none of the above
6. The frequency of vibration in case of simple harmonic motion
- (a) means the number of cycles per second
 - (b) represents time taken by the particle for one complete oscillation
 - (c) depends upon its amplitude
 - (d) is directly proportional to its beat
7. The velocity ratio of a simple wheel and axle with D and d as the diameters of effort wheel and load axle is
- (a) $D + d$
 - (b) $D - d$
 - (c) $D \times d$
 - (d) D/d
8. If a body is in equilibrium. We may conclude that
- (a) No force is acting on the body
 - (b) The resultant of all the forces acting on it is zero
 - (c) The moments of the forces about any point is zero

- (c) Both (b) and (c)
9. The maximum acceleration of a particle moving with simple harmonic motion is
- (A) ω
 - (B) ωr
 - (C) $\omega^2 r$
 - (D) ω/r
10. When the two ships are moving along inclined directions, then the time when the two ships will be closest together depends upon
- (a) velocity of one of the ships
 - (b) velocity of both the ships
 - (c) angle between the two directions
 - (d) all of the above

Section B

Five Questions of 02 Marks each

11. Differentiate between constant acceleration and variable acceleration using suitable diagrams
12. Write the conditions for perfect and imperfect frame
13. Define mechanical advantage and velocity ratio of a simple lifting machine
14. State the mathematical expression for equivalent stiffness of helical springs connected in (a) series and (b) parallel using diagrams as required
15. Define the terms (a) Angular Acceleration and (b) Angular Velocity

Section C

Seven Questions of 10 Marks each of which any 05 questions to be answered.

16. State and derive the theorem of Parallel Axis for Moment of Inertia for a plane figure.
17. A motor car takes 10 seconds to cover 30 meters and 12 seconds to cover 42 meters. Find the uniform acceleration of the car and its velocity at the end of 15 seconds.

18. A body performing simple harmonic motion has a velocity of 12 m/s when the displacement is 50 mm, and 3 m/s when the displacement is 100 mm, the displacement being measured from the mid-point. Calculate the frequency and amplitude of the motion. What is the acceleration when the displacement is 75 mm?
19. The law of a certain lifting machine is :

$$P = \frac{W}{50} + 8$$

- The velocity ratio of the machine is 100. Find the maximum possible mechanical advantage and the maximum possible efficiency of the machine. Determine the effort required to overcome the machine friction, while lifting a load of 600 N. Also calculate the efficiency of the machine at this load.
20. Determine the force in each member of the truss, and state if the members are in tension or compression.

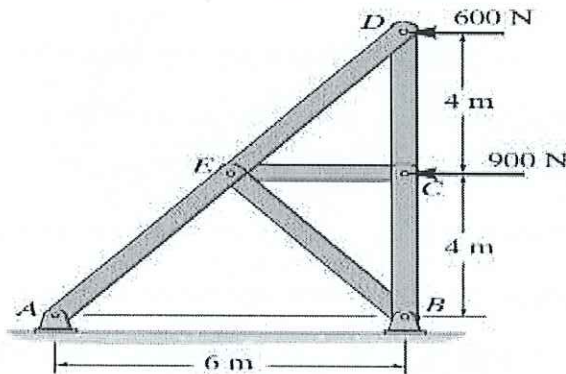

21. Derive an expression for the frequency of motion for a Compound Pendulum in terms of radius of gyration 'k'
22. A flywheel rotates with a constant retardation due to braking. From $t = 0$ to $t = 10$ seconds, it made 300 revolutions. At time $t = 7.5$ sec, its angular velocity was 40π rad/sec.
- Determine (i) value of constant retardation ; (ii) total time taken to come to rest and (iii) total revolutions made till it comes to rest.