

# PRODUCT DATA SHEET

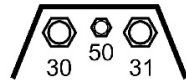

30 : BAT (M12-1.75P)  
 31 : MOTOR (M10-1.5P)  
 50 : S/W (M6-1.0P)

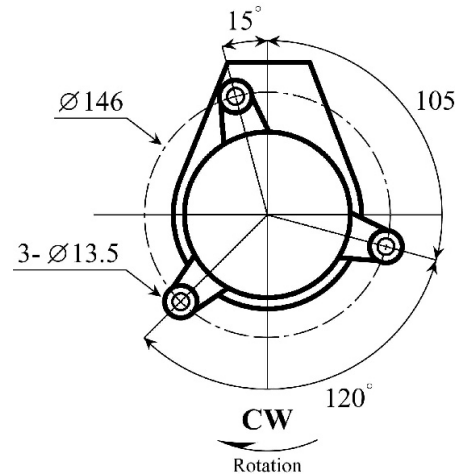
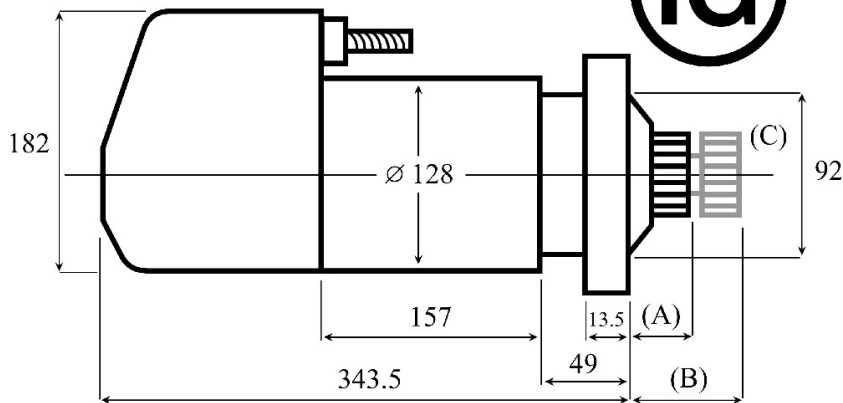

APPLICATION & X-REF	UNIT INFO	DRIVE / PINION DETAILS	PART No.	
MAN, MERCEDES-BENZ  0.001.411.022 0.001.411.037 0.986.012.960	Voltage: 24V IG Output: 6.6kW Rotation: Clockwise Engine Size: - Weight: 18kg Mounting Flange: SAE1	No. of teeth: 9 teeth Pinion OD: 35mm Pitch: Pinion rest position: 47.5±1mm Pinion travel position: 69.2±1mm	<b>860698</b>	
			DESCRIPTION / TYPE No. <b>KB TYPE STARTER</b>	
			24V / 6.6kW	
		REV 0		